



BIC[®] graphic

Writing Instruments

Sheaffer[®]

Sticky Note[™]

Notebooks

Ecolutions[®]

Lighters

Packaging



2015



FR > Nous aimerions commencer cette nouvelle année en vous remerciant sincèrement de votre soutien et de votre collaboration. Sans vous, nos précieux clients, BIC Graphic ne resterait pas un fournisseur de premier plan du secteur des produits promotionnels.

En 2015, BIC Graphic a porté l'impression numérique au niveau supérieur en l'appliquant à tous les corps translucides ou opaques des stylos BIC® Wide Body™ et BIC® Media Clic Grip. Désormais, il est également possible d'imprimer des marquages couleur de qualité photographique à 360° sur les composants couleur sur mesure de ces deux produits emblématiques. L'impression numérique a également contribué à étoffer notre gamme en nous permettant de lancer le BIC® Round Stic® Digital et le BIC® Super Clip Digital.

Nous avons par ailleurs introduit une nouvelle marque, BIC® Kids, avec les incontournables cires de couleur Plastidecor® et la possibilité de personnaliser la boîte avec votre propre logo.

Dans la famille des briquets BIC®, nous sommes tout particulièrement heureux d'introduire de nouvelles finitions en impression numérique : mates, métalliques, holographiques, et des options de personnalisation « puffy ».

Nous restons fidèles au passé en réaffirmant notre engagement envers vous et envers le secteur, et réinventons l'avenir en vous proposant des produits innovants et de qualité que vous pouvez commercialiser en toute confiance. La qualité du service et la ponctualité des livraisons sont autant d'atouts supplémentaires qui font de BIC Graphic un partenaire sûr au quotidien.

Merci à nouveau de votre soutien constant. Nous espérons avoir le plaisir de continuer à vous compter parmi nos clients en 2015 et au-delà.

Cordialement,

Bruno Bich
Président

ES > En el inicio de este nuevo año, queremos agradecerle su apoyo y colaboración. Sin Usted, nuestro apreciado cliente, BIC Graphic no podría seguir siendo el principal proveedor en el sector de productos promocionales.

En 2015, BIC Graphic ha llevado la impresión Digital a un nuevo nivel gracias a la posibilidad de imprimir esta técnica en cualquier cuerpo opaco o frosted, tanto en BIC® Wide Body™, como en BIC® Media Clic Grip. En adelante, también será posible la impresión 360° a todo color con calidad fotográfica sobre componentes de colores hechos a medida de estos dos productos emblemáticos. Además, la impresión digital ha ampliado su familia con el lanzamiento del BIC® Round Stic® Digital y del BIC® Super Clip Digital.

Asimismo, hemos introducido una nueva marca, BIC® Kids, con las icónicas ceras Plastidecor®, y la opción de personalizar el estuche con su propio logo.

En la familia de Encendedores de BIC®, estamos encantados de introducir nuevos acabados en impresión Digital, con opciones de personalización con acabado mate, metálico, holográfico y Puffy.

Continuamos honrando el pasado con nuestro compromiso con Usted y el sector al cual servimos mientras inventamos el futuro, proporcionándole productos innovadores y de calidad y servicios que puede vender con confianza. Con un servicio de alta calidad y entrega a tiempo, Usted puede contar con BIC Graphic todos los días.

De nuevo, gracias por su apoyo incondicional. Esperamos impacientes poder servirle durante el 2015 y en adelante.

Atentamente,

Bruno Bich
Presidente

DE > Zu Beginn dieses neuen Jahres möchten wir uns sehr herzlich für Ihre Unterstützung und gute Zusammenarbeit bedanken! Ohne Sie, unsere geschätzten Kunden, wäre BIC Graphic nicht länger unter den Top-Lieferanten der Werbeartikelbranche.

BIC Graphic hat einen weiteren Evolutionsschritt im Bereich des Digitaldrucks vollzogen und bietet ab 2015 die Möglichkeit, diese Drucktechnik auch auf jedem opaken oder gefrostenen Schaft der Serien "BIC® Wide Body™" und "BIC® Media Clic Grip" anzuwenden. Von nun an ist auch der 360°-Vollfarbdruck in Fotoqualität bei maßgefertigten Farbkompositionen auf diesen beiden emblematischen Produkten möglich. Zudem wurde, dank des Digitaldrucks, die Produktfamilie zusätzlich um die Einführung des "BIC® Round Stic® Digital" und des "BIC® Super Clip Digital" erweitert.

Darüber hinaus stellen wir Ihnen mit den ikonischen Plastidecor®-Wachsmalkreiden eine neue Marke, die "BIC® Kids", vor, bei denen Sie die Möglichkeit haben, die Box mit Ihrem eigenen Logo zu gestalten.

Bei der Produktfamilie der BIC® Feuerzeuge freuen wir uns sehr, Ihre neuen, maßgefertigten Ausführungen im Digitaldruck vorstellen zu können, wie das Matt-, Metallic-, Holographie- oder Puffy-Finish.

Wir werden auch weiterhin durch unseren Einsatz für Sie und die Branche, der wir dienen, die Vergangenheit in Ehren halten, während wir gleichzeitig die Zukunft erfinden, um Ihnen innovative, hochwertige Produkte und Dienstleistungen anzubieten, die Sie vertrauensvoll und unbesorgt weiter vertreiben können. Dank unserer hohen Qualitätsstandards und fristgemäßen Lieferzeiten können Sie sich jederzeit voll und ganz auf BIC Graphic verlassen.

Nochmals ganz herzlichen Dank für Ihre treue Unterstützung. Wir freuen uns darauf, Sie auch im Jahr 2015 und darüber hinaus weiterhin gut bedienen zu dürfen!

Freundliche Grüße,

Bruno Bich
Vorstand

IT > Con l'inizio del nuovo anno vogliamo esprimerle la nostra più sentita gratitudine per il sostegno e la cooperazione. Senza di voi, nostri preziosi clienti, BIC Graphic non potrebbe continuare a mantenere la posizione di fornitore leader nel settore dei prodotti promozionali.

Nel 2015 BIC Graphic ha rivoluzionato il sistema di stampa digitale introducendo questa tecnica su qualsiasi tipologia di fusto satinato e opaco, sia per BIC® Wide Body™ sia per BIC® Media Clic Grip. D'ora in avanti, la stampa a colori con qualità fotografica a 360° è possibile anche sui componenti in plastica di colore speciale di questi due emblematici prodotti. Inoltre, la stampa digitale ha ampliato la famiglia di prodotti grazie al lancio di BIC® Round Stic® Digital e BIC® Super Clip Digital.

Presentiamo inoltre un nuovo marchio, BIC® Kids, con gli iconici pastelli Plastidecor® e la possibilità di personalizzare la scatola col proprio logo.

All'interno della famiglia di accendini BIC®, siamo lieti di introdurre nuove ed entusiasmanti finiture di stampa digitale, finitura opaca, metallica, olografica e con inchiostro Puffy.

Continuiamo a onorare il passato con il nostro impegno verso di voi e verso il settore al quale ci rivolgiamo e a inventare il futuro, offrendovi prodotti innovativi e di qualità, e servizi che potete proporre con sicurezza. Grazie al servizio di elevata qualità e alla puntualità di consegna, potete sempre contare su BIC Graphic.

Vi ringraziamo nuovamente per il vostro costante sostegno. Non vediamo l'ora di essere nuovamente al vostro servizio nel 2015 e oltre.

Cordialmente,

Bruno Bich
Presidente

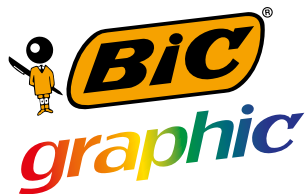

As we enter a new year, we want to genuinely thank you for your support and partnership. Without you, our valued customers, BIC Graphic wouldn't continue to be a top supplier in the promotional products industry.

In 2015, BIC Graphic has taken Digital printing to the next level by launching this printing technique on any frosted and opaque barrels in both BIC® Wide Body™ and BIC® Media Clic Grip. From now on, 360° photo-quality full-colour imprint is also possible in custom-made colour components of these two emblematic products. Moreover, Digital printing has also enlarged the family by launching BIC® Round Stic® Digital and BIC® Super Clip Digital.

In addition, we are introducing a new brand, BIC® Kids, with the iconic Plastidecor® crayons and the possibility to personalise the box with your own logo.

In the BIC® Lighters family, we are excited to introduce new finishes in Digital printing such as Digital with matte finish, Metallic, Holographic and Puffy customisation options.

We continue to honour the past with our commitment to you and the industry we serve, and to invent the future, bringing you innovative and quality products and services you can sell with confidence. With high-quality service and on-time delivery, you can count on BIC Graphic each and every day.

Thank you again for your ongoing support. We look forward to serving you in 2015 and beyond.

Sincerely,

Bruno Bich
Chairman

NEW



A NEW WORLD BEYOND PAPER

- Download the "BIC Graphic" application available both in the App Store for IOS devices, and in Google Play for Android.



- Look for **this icon** in the product pages of this catalogue and scan the page with your tablet or smartphone.
- Play around with the product configurator until you find your best component colour combination.
- Watch the product video.
- Live an incredible experience of Augmented Reality, with surprising effects that will stay in your mind.
- Enjoy it & share it!

WARNING: this experience can be exhilarating.



SCAN IT AND DOWNLOAD THE BIC GRAPHIC APPLICATION



FR > **UN NOUVEAU MONDE AU-DELÀ DU PAPIER**

- Téléchargez l'application "BIC Graphic" disponible sur l'App Store pour vos dispositifs sous IOS et sur Google Play pour Android.
- Recherchez **cet icône** sur les pages produits du catalogue et scannez la page avec votre tablette ou votre smartphone.
- Jouez avec le configurateur produit jusqu'à ce que vous trouviez la meilleure combinaison couleur.
- Regardez la vidéo produit
- Vivez une incroyable expérience de Réalité Augmentée, avec de surprenants effets qui resteront dans vos esprits.
- Amusez-vous et partagez !

ES > **UN NUEVO MUNDO MÁS ALLÁ DEL PAPEL**

- Descárgate la aplicación "BIC Graphic" disponible tanto en App Store para sistemas IOS, como en Google Play para Android.
- Busca **este icónico** en las páginas de producto de este catálogo y escanea la página con tu tableta o smartphone.
- Juega con el configurador de producto hasta que encuentres la combinación de colores de los componentes que más te guste.
- Mira el video de producto.
- Vive una experiencia increíble de Realidad Aumentada, con efectos sorprendentes que recordarás durante mucho tiempo.
- ¡Diviértete y compártelo!

DE > **EINE NEUE WELT JENSEITS VON PAPIER**

- Downloaden Sie sich die "BIC Graphic" App fr IOS-Gerte im App Store und fr Android in Google Play.
- Schauen Sie in den Katalogseiten nach **diesem Icon** und scannen Sie die Seite mit Ihrem Tablet oder Smartphone.
- Spielen Sie mit dem Produktkonfigurator und finden Sie die beste Komponenten-Farb-Kombination.
- Schauen Sie sich das Produkt-Video an
- Machen Sie eine beeindruckende, unvergessliche Erfahrung in der "erweiterten Realität" - mit überraschenden Effekten.
- Genießen Sie es und sagen Sie es weiter!

IT > **UN NUOVO MONDO DIETRO LA CARTA**

- Scarica l'applicazione "BIC Graphic" disponibile sia nell'App Store per dispositivi IOS che in Google Play per quelli Android.
- Cerca **questa icona** tra i prodotti nel catalogo e scansiona la pagina con il tuo tablet o smartphone.
- Gioca con il configuratore dei prodotti fino a trovare la migliore combinazione dei colori dei componenti.
- Guarda il video prodotto.
- Vivi un'incredibile esperienza di Realta' Aumentata, con effetti sorprendenti che rimarranno nella tua mente.
- Divertiti e condividilo!

ATTENTION: cette expérience peut être exaltante.

AVISO: esta experiencia puede ser excitante.

WARNING: diese Erfahrung kann berauschen wirken.

ATTENZIONE: questa esperienza può essere esilarante.



Table of Contents

Writing Instruments	42
Sheaffer®	114
Sticky Note™	144
Notebooks	168
Evolutions®	176
Lighters	196
Packaging	214
General Information	222
Product Index	228
Colour Table	229



FR > Les avantages

Gratuit !

- Coûts de préparation.
- Échantillons virtuels.
- Conception graphique.
- Échantillons physiques.
- Etc.

MIX & MATCH.

Plus de 10 000 combinaisons de couleurs GRATUITES pour les composants standard !

Reconnaissance de la marque BIC®

Votre nom sera associé à des produits de qualité. La marque BIC® est reconnue par 9 personnes sur 10 !

Développement durable

Nous proposons une gamme de produits fabriqués avec des matériaux recyclés ou des ressources renouvelables.

Sécurité produits

Nos produits sont conformes aux lois et aux réglementations internationales et de l'UE.

Disponibilité en stock

Des centaines de produits toujours disponibles en stock. Fabriqués et imprimés en EUROPE.

Expertise en matière d'impression

Plus de 45 années d'expérience dans le domaine de l'impression.

Service d'impression en 48 heures GRATUIT!

Plus de 100 produits !

ES > Las ventajas

¡Gratis!

- Gastos fijos de impresión
- Muestras virtuales
- Artes gráficas
- Muestras físicas
- Y mucho más...

MIX & MATCH

Más de 10.000 combinaciones de colores GRATUITAS para componentes estándar.

Reconocimiento de la marca BIC®

Tu nombre estará asociado con productos de calidad. La marca BIC® es reconocida por 9 de cada 10 personas.

Desarrollo sostenible

Ofrecemos un portafolio de productos fabricados con materiales reciclados o con recursos renovables.

Seguridad de los productos

Cumplimos con las leyes y los estándares europeos internacionales.

Compromiso de stock

Tenemos stock siempre disponible en cientos de artículos. Fabricados e impresos en EUROPA.

Experiencia en impresión

Más de 45 años de experiencia en impresión.

¡Servicio de impresión en 48 horas GRATIS!

¡Más de 100 productos!

DE > Die Vorteile von

Kostenlos !

- Druckeinrichtungskosten
- Virtuelle Muster
- Graphik und Design
- Materialmuster
- Und vieles andere mehr...

MIX & MATCH

Über 10.000 kostenlose Farbkombinationen bei den Standardkomponenten!

BIC® Markenerkennung

Ihr Name wird mit Qualitätsprodukten assoziiert. 9 von 10 Personen erkennen die Marke BIC®.

Nachhaltige Entwicklung

Wir bieten ein Sortiment von Produkten an, die aus recycelten Materialien oder erneuerbaren Ressourcen hergestellt wurden.

Produktsicherheit

Wir erfüllen alle EU- und internationalen Gesetze und Normen.

Lagerbestandszusicherung

Hunderte von Artikeln sind ständig am Lager verfügbar. Druck und Herstellung in EUROPA.

Höchste Fachkompetenz in Sachen Drucktechnik

Über 45 Jahre Erfahrung beim Druck.

48-Stunden-Druckservice KOSTENLOS!

Mehr als 100 Produkten!

IT > I vantaggi di

Gratis!

- Costi d'impianto.
- Campioni virtuali.
- Bozza grafica.
- Campioni.
- E altro ancora...

MIX & MATCH

Oltre 10.000 combinazioni di colori gratuite per i componenti standard!

Notorietà del marchio BIC®

Il vostro nome sarà associato a prodotti di altissima qualità. Il marchio BIC® è conosciuto da 9 persone su 10.

Sviluppo sostenibile

Offriamo una gamma di prodotti realizzati con materiali riciclati o con risorse sostenibili.

Sicurezza dei prodotti

Rispettiamo le leggi e le normative dell'Unione Europea e quelle internazionali.

Disponibilità di magazzino

Centinaia di articoli sempre a disposizione. Realizzati e stampati in EUROPA.

Competenza nella stampa

Oltre 45 anni di esperienza nella stampa.

Servizio di stampa in 48 ore GRATIS!

Oltre 100 prodotti!

The Advantage



Scan this page,
live the BIC Graphic
Augmented Reality
experience and
share it!

Free!

- Set-up Charges
- Virtual samples
- Production art
- Physical samples
- And much more...

MIX & MATCH

Over 10.000 FREE
standard component
colour combinations!

BIC®
Brand Name
Recognition

Your name will be
associated with
quality products.
The BIC® brand is
recognised by
9 out of 10 people.



Sustainable Development

We offer a range of products manufactured
with recycled materials or renewable resources.

Product Safety

We comply with EU
and international laws
and standards.

GUARANTEED

**Inventory
Promise**

Always in stock, with
hundreds of items.

Manufactured
and printed in
EUROPE

**Printing
Expertise**

More than 45 years of printing expertise.

**48h Printing
Service FREE!**

On over 100
products!

48h



FR > Une marque mondialement reconnue

Une solide réputation de fabricant de produits astucieux et abordables, allant au-delà des tendances.

La marque BIC® reconnue par **9 personnes sur 10 !**

- ✓ Leader ou **concurrent n° 1** dans la plupart des pays
- ✓ Produits commercialisés dans **160 pays**, sur **tous les continents**
- ✓ Présence mondiale avec **9 200 salariés** dans tous les coins du globe
- ✓ **46 millions** de produits BIC® sont achetés chaque jour* dans le monde entier :
- 25 M de produits de papeterie BIC®**
- 6 M de briquets BIC®**
- 10 M de rasoirs BIC®**
- 5 M de produits publicitaires et promotionnels**

- ✓ **67 300 clients dans le monde**
- ✓ Plus de **130 milliards** de stylos à bille et de briquets BIC® vendus depuis 1950**
- ✓ Plus de **70 ans** d'histoire et d'expertise
- ✓ Plus de **45 ans** dans le secteur des produits promotionnels
- ✓ Mise en œuvre de **programmes d'audit social**
- ✓ **Coté en bourse depuis 1972**

* Base : 220 jours
** Source : études internes

ES > Una marca reconocida a nivel mundial

Conocido como el fabricante de productos asequibles y bien hechos que van más allá de las tendencias.

¡La marca BIC® es **reconocida por 9 de cada 10 personas!**

- ✓ Líder o **principal competidor** en la mayoría de los países
- ✓ Ventas en **160 países**, en **cada continente**
- ✓ Presencia global con **9.200 trabajadores** por todo el mundo
- ✓ Cada día*, los consumidores escogen comprar **46 millones** de productos BIC® en todo el mundo:
- 25M Productos de papelería BIC®**
- 6M Encendedores BIC®**
- 10M Maquinillas de afeitar BIC®**
- 5M Productos publicitarios y promocionales**

- ✓ **67.300 consumidores en todo el mundo**
- ✓ Más de **130.000 millones** de Bolígrafos y Encendedores BIC® vendidos desde 1950**
- ✓ Más de **70 años** de historia y experiencia
- ✓ Más de **45 años** en el sector promocional.
- ✓ Implementa **programas de auditoría social**
- ✓ Cotiza **en Bolsa** desde **1972**

* Base: 220 días
** Fuente: estudios internos

DE > Eine weltbekanntere Markenname

BIC ist als Hersteller intelligenter und erschwinglicher Produkte bekannt, die über die aktuellen Trends hinausgehen.

Die Marke BIC® **kennen 9 von 10 Personen!**

- ✓ Marktführer oder **stärkster Wettbewerber** in den meisten Ländern
- ✓ Vertrieb in **160 Ländern** auf **allen Kontinenten**
- ✓ Globale Präsenz dank **9.200 Mitarbeitern** weltweit
- ✓ Jeden Tag* treffen Verbraucher weltweit die Entscheidung, **46 Millionen** BIC®-Produkte zu kaufen:
- 25 Mio Schreibwarenhandlungsprodukte**
- 6 Mio BIC®-Feuerzeuge**
- 10 Mio BIC®-Rasierer**
- 5 Mio Werbe- und Promotionsartikel**

- ✓ **67.300 Kunden weltweit**
- ✓ Über **130 Milliarden verkaufte** BIC® -Kugelschreiber und -Feuerzeuge seit 1950**
- ✓ Über **70 Jahre** Geschichte und Fachkompetenz
- ✓ Über **45 Jahre** im Werbeartikel- und Promotionsgeschäft
- ✓ Einführung **sozialer Auditprogramme**
- ✓ Seit **1972** an der **Börse** notiert

* Grundlage: 220 Tage
** Quelle: Internationale Studien

IT > Un marchio noto in tutto il mondo

Noto come produttore di articoli economici e di qualità che anticipano le tendenze.

Il marchio BIC® è **conosciuto da 9 persone su 10!**

- ✓ Leader o **principale concorrente** nella maggior parte dei paesi
- ✓ Distribuisce in **160 paesi**, in **tutti i continenti**
- ✓ Presenza globale con **9.200 dipendenti** in tutto il mondo
- ✓ Ogni giorno* nel mondo si acquistano **46 milioni** di prodotti BIC®:
- 25M Articoli di cancelleria**
- 6M Accendini BIC®**
- 10M Rasoi BIC®**
- 5M Prodotti pubblicitari e promozionali**

- ✓ **67.300 clienti in tutto il mondo**
- ✓ Più di **130 miliardi** di penne a sfera e accendini BIC® venduti dal 1950**
- ✓ Più di **70 anni** di storia e di esperienza
- ✓ Più di **45 anni** nel settore promozionale
- ✓ Messa in atto di **programmi di revisione sociale**
- ✓ Quotata in **borsa** dal **1972**

* Base: 220 giorni
** Fonte: studi interni



A worldwide recognised brand

Known as a manufacturer of smart and affordable products which go beyond the trends.

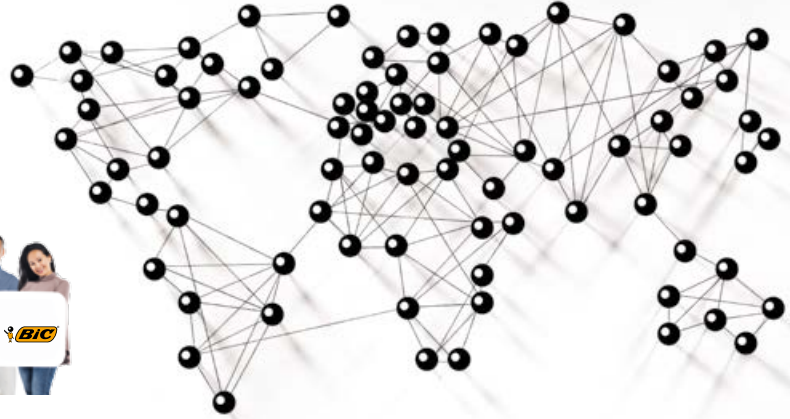

✓ The BIC® brand is recognised by 9 out of 10 people!

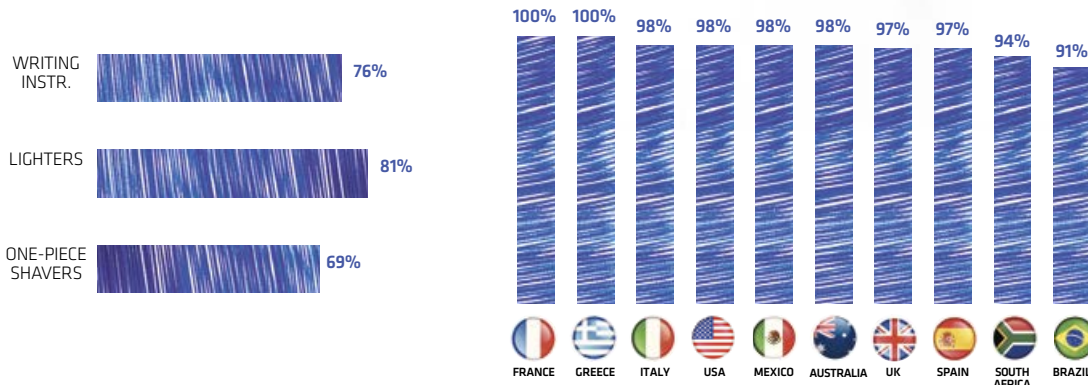

- ✓ **Leader** or **number one challenger** in most countries
- ✓ Sales in **160 countries**, on **every continent**
- ✓ Global presence with **9.200 employees** around the world
- ✓ Each day*, consumers choose to buy **46 million** BIC® products worldwide:

25M BIC® Stationery products **6M** BIC® Lighters **10M** BIC® Shavers **5M** Advertising and promotional products

- ✓ **67,300 customers** worldwide
- ✓ More than **130 billion** BIC® Ballpoint pens and Lighters sold since 1950**
- ✓ More than **70 years** of history and expertise
- ✓ More than **45 years** in the promotional business
- ✓ Implements **social audit programmes**
- ✓ Listed on the **stock exchange** since **1972**

* Base: 220 days
 ** Source: internal studies

DE RIGOUREUX SYSTÈMES DE CONTRÔLE DE QUALITÉ

- ✓ Chaque produit d'écriture fabriqué par nos soins fait l'objet d'une moyenne de **20 tests**.
- ✓ **100 % des briquets de poche BIC®** sont fabriqués dans nos **propres usines** avec des équipements d'assemblage en série de dernière génération.
- ✓ Chaque briquet BIC® fait l'objet de plus de **50 contrôles de qualité automatiques** durant le processus de fabrication.
- ✓ Tous les briquets de poche BIC® respectent les **spécifications de la norme internationale de qualité ISO 9994** ou vont au-delà.
- ✓ Tous les briquets BIC® vendus dans l'UE **sont conformes à la norme EN 13869 relative aux briquets de sécurité enfants**. Un briquet "sécurité-enfants" n'est pas un briquet exempt de tout risque pour les enfants: c'est un briquet que 85% au moins des enfants de moins de 51 mois ne peuvent pas faire fonctionner

DES INSTALLATIONS ET DES ÉQUIPEMENTS HAUTEMENT TECHNOLOGIQUES

- ✓ **85 %** des produits BIC® sont fabriqués dans des usines du groupe BIC.
- ✓ **60 %** des produits BIC Graphic sont fabriqués dans ses propres usines.
- ✓ **4 usines principales** pour BIC Graphic: 3 aux États-Unis et 1 en Europe.

PROCESSUS DE PRODUCTION INTÉGRÉ

- ✓ Le groupe **conçoit et développe** la plupart de ses **propres machines**, et maîtrise les technologies de fabrication les plus récentes.

AMÉLIORATION CONTINUE DANS NOS USINES

- ✓ BIC Graphic Europe s'est vu décerner, **par Lloyd's Register, les certifications ISO 9001 et ISO 14001 relatives aux systèmes de gestion intégrée pour les installations de Tarragone (Espagne)**.
- ✓ BIC Graphic Europe détient la certification de qualité **ISO 9001 depuis l'an 2000**. En juillet 2014, nous avons passé avec succès l'audit de certification ISO 9001 - ISO 14001. **L'ISO 9001 nous a été renouvelée** et nous avons obtenu, pour la première fois, la **certification environnementale ISO 14001!**
- ✓ Quelques chiffres concernant nos installations pour illustrer les buts que nous avons atteints: plus de **19 000 m², 400 salariés et 25 processus ont été audités**.
- ✓ Cette double certification démontre notre engagement sans faille en matière de satisfaction clients, d'amélioration continue, de qualité et d'environnement.

RIGUROSOS SISTEMAS DE CONTROL DE CALIDAD

- ✓ Se realizan un promedio de **20 pruebas** en cada Instrumento de Escritura que se fabrica en nuestras instalaciones.
- ✓ El **100% de los encendedores de bolsillo BIC®** se producen en nuestras propias fábricas con equipos técnicos de ensamblaje de última generación.
- ✓ Cada Encendedor BIC® se somete a más de **50 controles de calidad automáticos** durante su proceso de fabricación.
- ✓ Todos los Encendedores de bolsillo BIC® cumplen o exceden los **estándares de seguridad internacionales ISO 9994**.
- ✓ Todos los Encendedores BIC® vendidos en la UE **cumplen con la normativa EN 13869 de seguridad para niños**, que asegura que al menos el 85% de los niños menores de 51 meses no pueden encenderlo.

INSTALACIONES Y EQUIPOS DE ALTA TECNOLOGÍA

- ✓ El **85%** de los productos BIC® se producen en fábricas del Grupo BIC.
- ✓ El **60%** de los productos BIC Graphic se fabrican en sus propias fábricas.
- ✓ **4 fábricas principales** en BIC Graphic: 3 en Estados Unidos y 1 en Europa.

PROCESO DE PRODUCCIÓN INTEGRADO

- ✓ El Grupo **diseña y desarrolla** la mayor parte de **su maquinaria** y controla las últimas tecnologías de fabricación.

MEJORAS CONTINUAS EN NUESTRAS FÁBRICAS

- ✓ BIC Graphic Europe ha recibido las **ISO 9001 - ISO 14001 de Gestión Integrada de Sistemas de Certificaciones de la agencia Lloyd para las instalaciones de Tarragona**.
- ✓ BIC Graphic Europe posee la certificación **ISO 9001 en Calidad desde el año 2000**. En julio de 2014, se llevó a cabo con éxito la auditoría de la norma ISO 9001 - ISO 14001. Se renovó la **ISO 9001** y, por primera vez, se entregó la Certificación **ISO 14001 en Medio Ambiente**.
- ✓ Algunas cifras de nuestras instalaciones que ilustran la meta que se ha logrado: más de **19.000 m², 400 empleados y 25 procedimientos distintos auditados**.
- ✓ Esta doble certificación es una muestra sólida de nuestro continuo compromiso con la Satisfacción del Cliente, Mejora Permanente, Calidad y Medio Ambiente.

STRENGE QUALITÄTSKONTROLLSYSTEME

- ✓ Jedes Schreibgerät, das bei uns gefertigt wird, durchläuft durchschnittlich **20 Tests**.
- ✓ **100% der BIC®-Taschenfeuerzeuge** werden in unseren **eigenen Fabriken** mit modernstem Massenproduktions-Equipments hergestellt.
- ✓ Jedes BIC®-Feuerzeug durchläuft über **50 verschiedene automatische Qualitätstests** während seines Herstellungsprozesses.
- ✓ Alle BIC®-Taschenfeuerzeuge erfüllen bzw. übertreffen die **internationalen Sicherheitsnormen der ISO 9994 - Spezifikationen**.
- ✓ Alle in der EU verkauften BIC®-Feuerzeuge werden gem. den geltenden **Bestimmungen nach EN 13869 zur Kindersicherheit** hergestellt. Ein kindersicheres Feuerzeug ist ein Feuerzeug, das mind. 85% der Kinder unter 51 Monaten nicht bedienen können.

HIGH-TECH-EINRICHTUNGEN UND -EQUIPMENT

- ✓ **85%** der BIC® Produkte werden in Fabriken der BIC-Gruppe hergestellt.
- ✓ **60%** der BIC Graphic-Produkte werden in ihren eigenen Fabriken produziert.
- ✓ **Vier Hauptwerke** für BIC Graphic: Drei in den USA und eines in Europa.

INTEGRIERTER PRODUKTIONSPROZESS

- ✓ Die Unternehmensgruppe **entwirft und entwickelt** viele ihrer **eigenen Maschinen selbst** und beherrscht alle neuesten Produktionstechnologien.

STETIGE WEITERVERBESSERUNG IN UNSEREN FABRIKEN

- ✓ BIC Graphic Europe hat die Zertifizierungen gem. **ISO 9001 - ISO 14001 für integrierte Qualitäts- und Umweltmanagementsysteme für ihre Werke in Tarragona vom Lloyd's Register erhalten**.
- ✓ BIC Graphic Europe wird seit dem Jahr **2000 für seine Qualität gem. ISO 9001** zertifiziert. Im Juli 2014 haben wir auch das Audit für die Zertifizierung gem. ISO 9001 - ISO 14001 erfolgreich durchgeführt. Die **ISO 9001-Zertifizierung wurde erneuert und zum ersten Mal wurde auch die ISO 14001-Zertifizierung für Umweltmanagement erteilt!**
- ✓ Hier einige anschauliche Zahlen, die Ihnen verdeutlichen, welches anspruchsvolle Ziel erreicht wurde: Über **19.000 m², 400 Arbeiter und 25 unterschiedliche Prozesse wurden geprüft**.
- ✓ Diese doppelte Zertifizierung ist ein eindrucksvoller Beweis unseres fortlaufenden Bemühens um Kundenzufriedenheit, stetige Weiterverbesserungen, Qualität und Umweltschutz.

RIGOROSI SISTEMI DI CONTROLLO DELLA QUALITÀ

- ✓ Eseguiamo in media **20 test** su ogni strumento di scrittura prodotto internamente all'azienda.
- ✓ Il **100% degli accendini tascabili BIC®** è realizzato nei nostri stabilimenti con attrezzature di assemblaggio all'avanguardia.
- ✓ Ogni accendino BIC® viene sottoposto a oltre **50 controlli di qualità automatici separati** durante il processo di produzione.
- ✓ Tutti gli accendini tascabili BIC® soddisfano o superano i requisiti delle **norme internazionali di sicurezza ISO 9994**.
- ✓ Tutti gli accendini BIC® venduti nell'UE **sono conformi alla normativa EN 13869 sulla sicurezza dei bambini**. Un accendino a prova di bambino è un dispositivo che almeno l'85% dei bambini di età inferiore a 51 mesi non è in grado di far funzionare

STABILIMENTI E ATTREZZATURE TECNOLOGICAMENTE ALL'AVANGUARDIA

- ✓ L'**85%** dei prodotti BIC® è realizzato negli stabilimenti del Gruppo BIC.
- ✓ Il **60%** dei prodotti BIC Graphic è realizzato negli stabilimenti dell'azienda.
- ✓ **4 principali stabilimenti** BIC Graphic: 3 negli USA e 1 in Europa.

PROCESSO DI PRODUZIONE INTEGRATO

- ✓ Il Gruppo **progetta e sviluppa** buona parte dei **propri macchinari** e conosce alla perfezione tutte le ultime tecnologie produttive.

CONTINUI MIGLIORAMENTI ALL'INTERNO DEI NOSTRI STABILIMENTI

- ✓ BIC Graphic Europe ha ricevuto le **certificazioni di Sistema di Gestione Integrato ISO 9001 - ISO 14001 per gli stabilimenti di Tarragona da Lloyd's Register**.
- ✓ BIC Graphic Europe ha ottenuto la certificazione di **qualità ISO 9001 dal 2000**. Nel mese di luglio 2014 abbiamo superato brillantemente la revisione per la certificazione ISO 9001 - ISO 14001. L'**ISO 9001 è stata rinnovata** e, per la prima volta, **ci è stata rilasciata la certificazione ISO 14001 per la gestione ambientale**.
- ✓ Alcune delle cifre dai nostri stabilimenti che illustrano gli obiettivi raggiunti: più di **19.000 m², 400 operai e 25 diversi processi revisionati**.
- ✓ Questa doppia certificazione è un forte segnale del nostro costante impegno verso la soddisfazione del cliente, il miglioramento continuo, la qualità e la tutela dell'ambiente.



The quality difference

RIGOROUS QUALITY-CONTROL SYSTEMS

- ✓ An average of **20 tests** are performed on each Writing Instrument product manufactured in-house.
- ✓ **100%** of BIC® pocket lighters are made at our **own factories** with state-of-the-art mass assembly equipment.
- ✓ Every BIC® lighter undergoes more than **50 separate automatic quality checks** during the manufacturing process.



- ✓ All BIC® pocket lighters meet or exceed the **international safety specifications of ISO 9994.**



- ✓ All BIC® lighters sold in the European Union **comply with the EN 13869 Child Resistance regulation.** A Child-resistant lighter is a lighter that cannot be operated by at least 85% of children under the age of 51 months.



Scan this page, live the BIC Graphic Augmented Reality experience and share it!



HIGH-TECHNOLOGY FACILITIES AND EQUIPMENT

- ✓ **85%** of BIC® products are manufactured at BIC Group factories.
- ✓ **60%** of BIC Graphic products are manufactured at its own factories.
- ✓ **4 main BIC Graphic factories:** 3 in the United States and 1 in Europe.

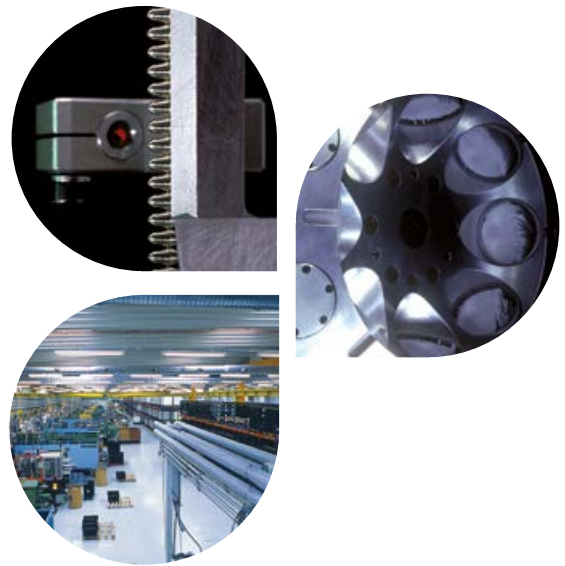

INTEGRATED PRODUCTION PROCESS

- ✓ The Group **designs and develops** much of its **own machinery** and masters all the latest manufacturing technologies.

CONTINUOUS IMPROVEMENT AT OUR FACTORIES

- ✓ BIC Graphic Europe received **ISO 9001 - ISO 14001 Integrated Management System Certifications for the Tarragona facilities** from Lloyd's Register.
- ✓ BIC Graphic Europe has been certified for **ISO 9001 in Quality since 2000.** In July 2014, we successfully carried out the audit for ISO 9001 -ISO 14001 Certification. **ISO 9001 Certification was renewed** and **ISO 14001 Certification for the Environment was delivered** for the very first time.
- ✓ Some figures on our facilities to illustrate what has been achieved: more than **19.000 m², 400 workers and 25 different processes audited.**

- ✓ This double certification is a strong indication of our continued commitment to Customer Satisfaction, Continuous Improvement, Quality and the Environment.



RÈGLE N° 1
"ACHETER EN TOUTE CONFIANCE"
 Nous nous tenons au Code! C'est très simple: si vous souhaitez devenir l'un des fournisseurs de BIC Graphic, vous devez signer le Code de conduite du groupe. Conditions de travail, qualité, sécurité: BIC Graphic sélectionne ses partenaires avec le plus grand soin et effectue régulièrement des audits de conformité dans leurs usines pour s'assurer qu'ils respectent leurs engagements.

RÈGLE N° 2
"N'ACCEPTER RIEN DE MOINS QUE LA CONFORMITÉ À 100 %"
 Les produits proposés par BIC Graphic sont les «porte-parole» d'une marque. Nous devons donc leur porter toute l'attention qu'ils méritent! Ils doivent non seulement être percutants et adaptés au public auquel ils sont destinés, mais aussi respecter les normes et réglementations en vigueur. Là non plus, BIC Graphic ne fait pas de compromis: nous appliquons systématiquement les réglementations les plus strictes dans chaque région du globe.

RÈGLE N° 3
"FOURNIR DES PRODUITS UTILES ET CRÉATIFS"
 Les produits proposés par BIC Graphic doivent non seulement être utiles et robustes, mais aussi bien conçus, séduisants et créatifs. Ils doivent également disposer d'une surface d'impression suffisante pour mettre efficacement en lumière le logo du client. C'est ensuite la technologie BIC Graphic qui fait toute la différence, de sorte qu'un simple stylo à bille ou un simple briquet laisse une impression durable.

RÈGLE N° 4
"SUIVRE L'AIR DU TEMPS"
 Comme les vêtements, les articles promotionnels sont tributaires des modes. Il est donc essentiel de surfer sur la vague des tendances! Comme un chercheur en design, l'équipe de BIC Graphic écume les magasins à la mode, les sites Internet et les salons spécialisés

du monde entier pour que le catalogue soit toujours au diapason de son temps. Mais attention à ne pas confondre les tendances et les engouements qui ne sont que de simples feux de paille: BIC Graphic ne surfe que sur les grandes vagues, celles qui durent!

RÈGLE N° 5
"S'EFFORCER DE FOURNIR UNE QUALITÉ DE SERVICE EXCEPTIONNELLE"
Allô, pronto, Alô, bom dia?
 Chez BIC Graphic, nous ne nous contentons pas de parler la même langue que nos clients, nous venons du même pays. C'est essentiel pour être capable de proposer les bons produits au bon moment ou mieux encore, pour anticiper ce que les clients veulent et leur fournir des produits originaux parfaitement en accord avec la culture locale.

RÈGLE N° 6
"RESPECTER SCRUPULEUSEMENT CHAQUE DÉLAI"
5 000 stylos aux couleurs de votre entreprise pour la semaine prochaine? Nous y arriverons.
 Ce sera bien entendu plus facile et nous pourrions vous proposer plus d'options si vous vous y prenez un peu plus à l'avance, mais en cas d'urgence, BIC Graphic pourra vous fournir ce dont vous avez besoin. Le secret? Nous nous chargeons nous-mêmes de l'impression des produits que nous avons en stock: cela nous permet de garantir un temps de réaction très rapide et un produit fini de la plus haute qualité.

RÈGLE N° 7
"CHÉRIR SES DISTRIBUTEURS"
Que ne ferions-nous pas pour notre famille?
 Depuis de nombreuses années, BIC Graphic fait confiance à un solide réseau constitué de milliers de distributeurs spécialisés dans les articles promotionnels et ayant eux-mêmes une connaissance approfondie des attentes de leurs clients. Dans les pays où le marché est en voie de développement, BIC Graphic travaille essentiellement avec des distributeurs de produits BIC® classiques.

REGLA 1
"COMPRARÉ CON CONFIANZA"
 ¡Nos regimos por el Código! Es sencillo – si quieres ser proveedor de BIC Graphic, tienes que firmar el Código de Conducta del Grupo. Condiciones de trabajo, calidad, seguridad: BIC Graphic tiene el máximo cuidado en la selección de socios y regularmente lleva cabo auditorías de cumplimiento en sus fábricas para asegurarse de que se mantienen sus compromisos.

REGLA 2
"SÓLO ACEPTARÉ EL 100% DEL CUMPLIMIENTO"
 Los productos que BIC Graphic ofrece básicamente son portavoces de una marca, así que ¡tenemos que hacerles justicia!
 El artículo no sólo debe ser apropiado para el público e impactar, sino que también debe cumplir con todas las normativas aplicables. BIC Graphic tampoco se queda corto en esto, sistemáticamente aplicamos el nivel más alto de regulación para cada región.

REGLA 3
"PROVEERÉ PRODUCTOS PRÁCTICOS Y CREATIVOS"
 El producto que ofrece BIC Graphic no sólo debe ser práctico y robusto, sino que también tiene que estar bien diseñado, ser atractivo y creativo. Además, debe tener una superficie de impresión que sea lo suficientemente grande para destacar el logo del cliente. Es por ello que la tecnología de BIC Graphic marca la diferencia, de manera que un simple bolígrafo o encendedor tenga una impresión duradera.

REGLA 4
"ESTARÉ ACTUALIZADO"
 En los artículos promocionales existen modas al igual que en la ropa; ¡la clave está en surfear las tendencias! Como un investigador de diseño, el equipo de BIC Graphic busca en las tiendas de moda, en páginas de Internet y en ferias

especializadas en todo el mundo para que el catálogo esté siempre a la última. Pero cuidado con confundir tendencias con modas pasajeras: BIC Graphic ofrece surfear las olas más grandes, jaquellas que perduran!

REGLA 5
"ME ESFORZARÉ POR UN SERVICIO DE ALTA CALIDAD"
Allô, pronto, Alô, bom dia?
 En BIC Graphic no sólo hablamos los idiomas de nuestros clientes, sino que procedemos del mismo país. Esto es esencial si queremos ser capaces de ofrecer los productos adecuados en el tiempo adecuado, o incluso mejor, si queremos anticiparnos a lo que nuestros clientes quieren y ofrecerles productos originales que encajen al 100% con la cultura local.

REGLA 6
"CUMPLIRÉ ESCRUPULOSAMENTE CON CADA PLAZO"
¿5.000 bolígrafos con los colores de su empresa para la próxima semana? Podemos hacerlo.
 Por supuesto, es más fácil cuando se organizan las cosas con un poco de antelación, pero si no hay más remedio, BIC Graphic todavía podrá proveerle de lo que necesite. ¿El secreto? Realizamos la impresión nosotros mismos con los productos que tenemos en stock; esto nos permite garantizar una reacción más rápida y un producto acabado de la calidad más alta.

REGLA 7
"AMARÉ A MIS DISTRIBUIDORES"
Lo que no se hace por la familia...
 Durante muchos años, BIC Graphic ha sido capaz de confiar en una amplia y sólida red de miles de distribuidores especializados en artículos de promoción, quienes a su vez tienen un profundo conocimiento sobre las expectativas de sus clientes. En los países con mercados en desarrollo, BIC Graphic trabaja principalmente con distribuidores de productos clásicos de BIC®.

REGEL 1
"ICH WERDE MIT VERTRAUEN EINKAUFEN"
 Wir bürgen für diesen Kodex! Es ist ganz einfach: Wenn Sie Lieferant für BIC Graphic werden wollen, müssen Sie den Verhaltenskodex der BIC-Gruppe unterzeichnen. Arbeitsbedingungen, Qualität, Sicherheit: BIC Graphic wählt seine Geschäftspartner mit größtmöglicher Sorgfalt aus und führt regelmäßige Compliance Audits in deren Fabriken durch, um sicherzugehen, dass sie ihre Verpflichtungen auch einhalten.

REGEL 2
"ICH AKZEPTIERE NUR 100 % COMPLIANCE"
 Von BIC Graphic angebotene Produkte sind das Sprachrohr der Marke, daher müssen wir ihnen gerecht werden!
 Die betreffenden Artikel müssen nicht nur für das entsprechende Klientel geeignet und aufmerksamkeitsstark sein, sie müssen auch sämtliche anwendbare Standards erfüllen. BIC Graphic macht auch hier keine Kompromisse: Wir wenden systematisch die für die jeweilige Region geltenden strengsten Bestimmungen und Vorschriften an.

REGEL 3
"ICH WERDE NÜTZLICHE UND KREATIVE PRODUKTE ANBIETEN"
 Ein von BIC Graphic angebotenes Produkt muss nicht nur nützlich, stabil und robust, sondern auch gut gestaltet, ansprechend und kreativ sein. Zudem muss es über eine bedruckbare Oberfläche verfügen, die groß genug ist, um das Logo des jeweiligen Kunden wirkungsvoll in Szene zu setzen. Von diesen Kriterien ausgehend, macht BIC Graphic den großen Unterschied und auch ein noch so simpler Kugelschreiber oder ein einfaches Feuerzeug hinterlassen einen bleibenden Eindruck.

REGEL 4
"ICH WERDE AUF DEM LAUFENDEN BLEIBEN"
 Ebenso, wie bei der Bekleidung, gibt es auch bei den Werbeartikeln bestimmte Modetendenzen. Auf der Trendwelle zu surfen, ist hier das Richtige! Genauso wie ein Designforscher, so durchforstet auch das Team von BIC Graphic die schicksten

Geschäfte, angesagtesten Webseiten und Fachhandelsmessen der Welt, damit der Katalog immer auf der Höhe seiner Zeit ist. Verwechseln Sie Trends aber nicht mit kurzlebigen Moderecheinungen: BIC Graphic bietet Artikel mit Tiefgang, solche, die bleiben werden!

REGEL 5
"ICH WERDE DEN HÖCHSTEN QUALITÄTS-SERVICE" ANSTREBEN"
Allô, pronto, Alô, bom dia?
 Bei BIC Graphic sprechen wir nicht nur dieselbe Sprache wie unsere Kunden, wir kommen auch aus demselben Land. Das ist deshalb so wichtig, weil wir die richtigen Produkte zur richtigen Zeit offerieren oder gar vorhersehen möchten, was unsere Kunden wirklich wollen, um ihnen dann die Originalprodukte anzubieten, die zu 100% die kulturellen Ansprüchen vor Ort erfüllen.

REGEL 6
"ICH WERDE JEDE FRIST PÜNKLICHST EINHALTEN"
5.000 Stifte in Ihren Unternehmensfarben nächste Woche? Das können wir machen.
 Natürlich gibt es mehr Möglichkeiten, wenn man die Dinge ein bisschen besser im Voraus planen kann, aber in der Not kann BIC Graphic Ihnen trotzdem das bieten, was Sie benötigen. Das Geheimnis? Wir drucken selbst und auf Produkten, die wir auf Lager haben. Dadurch können wir die schnellsten Reaktionszeiten ebenso garantieren, wie ein fertiges Produkt, das den höchsten Qualitätsansprüchen genügt.

REGEL 7
"ICH WERDE MEINE VERTRIEBSPARTNER HEGEN UND PFLEGEN"
Was tun wir nicht alles für die Familie...
 Seit vielen Jahren kann sich BIC Graphic bereits auf ein großes, solides Netzwerk mehrerer tausend Vertriebspartner verlassen, die auf Werbeartikel spezialisiert sind und über detaillierte Kenntnisse der Erwartungen ihrer Endkunden verfügen. In Ländern mit Schwellenmärkten arbeitet BIC Graphic zumeist mit Vertriebspartnern der klassischen BIC®-Produkte zusammen.

REGOLA 1
"ACQUISTERÒ CON SICUREZZA"
 Ci atteniamo al Codice! È semplice: se vuoi diventare fornitore per BIC Graphic devi sottoscrivere il Codice di Condotta del Gruppo. Condizioni di lavoro, qualità, sicurezza: BIC Graphic seleziona con la massima cura i propri partner ed esegue regolarmente controlli di conformità nei loro stabilimenti per verificare il rispetto degli impegni contrattati.

REGOLA 2
"ACCETTERÒ SOLO IL 100% DI CONFORMITÀ"
 I prodotti offerti da BIC Graphic sono sostanzialmente i "portavoce" del marchio, ragioni per cui dobbiamo accertarci che siano il meglio in circolazione!
 Non solo un articolo deve essere adeguato alla clientela e d'impatto, ma deve anche soddisfare tutte le norme vigenti. Anche qui BIC Graphic non scende a compromessi, applicando sistematicamente i più elevati standard normativi per ciascuna regione.

REGOLA 3
"FORNIRÒ PRODOTTI UTILI E CREATIVI"
 Un prodotto offerto da BIC Graphic non solo deve essere utile e robusto, ma anche ben progettato, accattivante e creativo. Deve inoltre offrire una superficie di stampa abbastanza ampia da esibire efficacemente il logo del cliente. È qui che fa la differenza la tecnologia di BIC Graphic grazie alla quale una semplice penna a sfera o un accendino lasciano un'impronta durevole.

REGOLA 4
"RESTERÒ AL PASSO COI TEMPI"
 Esistono mode nel settore degli articoli promozionali, proprio come nell'abbigliamento – la chiave è restare a cavallo delle tendenze! Come gli scopritori di tendenze, il team BIC Graphic ricerca nei negozi più alla moda, tra i

siti internet e alle fiere specializzate in tutto il mondo, in modo che il nostro catalogo sia sempre al passo coi tempi. Ma attenzione a non confondere le tendenze con effimere mode: BIC Graphic cavalca sempre l'onda più alta, quella che dura!

REGOLA 5
"MI IMPEGNERÒ A OFFRIRE UN SERVIZIO DELLA MIGLIORE QUALITÀ"
Allô, pronto, Alô, bom dia?
 In BIC Graphic non solo parliamo la stessa lingua dei nostri clienti, ma veniamo dal loro stesso paese. Ciò è essenziale per poter offrire i prodotti giusti al momento giusto, o ancor meglio, anticipare i desideri della clientela e offrire prodotti originali che siano al 100% concepiti su misura per la cultura locale.

REGOLA 6
"RISPETTERÒ SCRUPOLOSAMENTE OGNI SCADENZA"
5.000 penne nei colori della vostra società per la prossima settimana? Possiamo farlo.
 Naturalmente ci sono più possibilità quando organizzati le cose con un certo anticipo, ma in caso di emergenza BIC Graphic può soddisfare la tua esigenza. Il segreto? Stampiamo internamente i prodotti che abbiamo in stock; questo ci permette di garantire i tempi di reazione più veloci ed un prodotto realizzato con alta qualità.

REGOLA 7
"AVRÒ CURA DEI MIEI DISTRIBUTORI"
Cosa non faremmo per la famiglia...
 Per molti anni BIC Graphic ha potuto affidarsi a una vasta e solida rete di svariate migliaia di distributori specializzati in articoli promozionali, i quali, a loro volta, vantavano una profonda conoscenza delle aspettative dei propri clienti finali. Nei paesi con mercati in espansione, BIC Graphic opera principalmente con i distributori dei classici prodotti BIC®.

The 7 golden rules

for  **BIC** graphic



* RULE NO. 1 *

"I WILL BUY WITH CONFIDENCE"

We stand by the Code! It's simple – if you want to be a supplier for BIC Graphic, **you have to sign the Group's Code of Conduct**. Working conditions, quality, safety: BIC Graphic takes the utmost care when selecting the partners and regularly carries out compliance audits in their factories to make sure that they keep their commitments.



* RULE NO. 2 *

"I WILL ONLY ACCEPT 100% COMPLIANCE"

Products that BIC Graphic offers are basically "spokespeople" for a brand, so we have to do them justice! Not only does the item have to be appropriate to the audience and impactful, it also has to meet all applicable standards. BIC Graphic cuts no corners here either; we systematically **apply the highest level of regulations for each region**.



* RULE NO. 3 *

"I WILL PROVIDE USEFUL AND CREATIVE PRODUCTS"

A product that BIC Graphic offers not only **has to be useful and sturdy, but it also has to be well designed, appealing and creative**. It also has to provide a printing surface that is big enough to effectively display the client's logo. From there, BIC Graphic technology makes all the difference and a simple ballpen or lighter makes a **lasting impression**.

* RULE NO. 4 *

"I WILL REMAIN IN STEP WITH THE TIMES"

There are fashions in promotional items just like in clothing – surfing the trends is key! Like a design investigator, **the BIC Graphic team scour the hippest stores, Internet sites and specialty trade fairs the world over so that the catalogue is always right in step with the times**. Be careful not to confuse trends with passing fad products: BIC Graphic offers to surf the deep waves, the ones that last!

* RULE NO. 5 *

"I WILL STRIVE FOR THE HIGHEST QUALITY SERVICE"

Allô, pronto, Alô, bom dia ?

At BIC Graphic, not only we do speak the same language as our clients, we come from the same country. That's essential if we are to be able to offer the right products at the right time, or even better, **anticipate what clients want and give them original products that are 100% on target for the local culture**.

* RULE NO. 6 *

"I WILL SCRUPULOUSLY MEET EVERY DEADLINE"

5.000 pens in your company colours next week? We can do that. Of course, there are more possibilities when you organise things a bit more in advance, but at a pinch, BIC Graphic can still provide what you need. The secret? We do the printing ourselves with products that we have in stock; this allows us to guarantee **the quickest reaction time and a finished product of the highest quality**.

* RULE NO. 7 *

"I WILL CHERISH MY DISTRIBUTORS"

What we won't do for family... For many years, BIC Graphic has been able to rely on a broad, solid network of several thousand distributors specialising in promotional items and **who themselves have in-depth knowledge of their end clients' expectations**. In countries with developing markets, BIC Graphic works mostly with distributors of classic BIC® products.

Un **ENGAGEMENT** qui remonte à plus de 10 ANS. L'approche du groupe BIC en matière de développement durable repose sur un ensemble de documents qui définissent notre vision et le cadre des activités quotidiennes de chaque salarié afin de garantir le respect des principes du développement durable.

LE PROGRAMME DE DÉVELOPPEMENT DURABLE DE BIC C'est en 2003 que le groupe BIC a lancé son Programme de développement durable, dont les objectifs sont les suivants:

- **Développer le bon sens écologique :** pour limiter sa consommation de ressources naturelles, le groupe s'efforce de minimiser l'utilisation de matières premières dans ses produits et ses emballages tout en introduisant progressivement de nouveaux matériaux écologiques, recyclés et renouvelables.
- **Réduire l'impact environnemental :** conscient de l'impact environnemental de ses produits, de ses usines et de ses activités de transport, BIC a mis en œuvre des actions visant à le réduire.
- **Construire des relations quotidiennes basées sur la confiance :** BIC s'efforce également de renforcer les compétences et l'employabilité des salariés, d'améliorer leur qualité de vie sur leur lieu de travail et de promouvoir des initiatives locales pour soutenir les communautés.

LES OBJECTIFS DU GROUPE BIC a identifié les principaux objectifs liés aux phases clés de ses activités, de la fourniture des matières premières à l'utilisation des produits et à la gestion de leur fin de vie utile.

- ACHATS
- PRODUCTION
- DISTRIBUTION
- UTILISATION
- FIN DE VIE UTILE

Vous pouvez consulter la totalité de l'information sur www.bicgraphic.com

LE BAROMÈTRE

BIC contrôle et évalue les progrès de son Programme de développement durable à l'aide du Baromètre BIC. Ce baromètre, qui est actualisé tous les trois ans, définit dix engagements en matière de développement durable, associés à dix indicateurs de performance.

PRODUITS

1. Lancer des produits innovants et respectueux de l'environnement
 2. Créer des produits pour développer les marchés
 3. Proposer des produits BIC® présentant des avantages environnementaux
- INDUSTRIE
4. Sélectionner des matériaux de packaging respectueux de l'environnement
 5. Améliorer la performance environnementale des usines BIC
 6. Minimiser le transport aérien
- SOCIAL/SOCIÉTAL
7. Maintenir un faible taux d'accidents de travail
 8. Intensifier la mise en œuvre du Code de conduite du groupe BIC
 9. Développer l'engagement des salariés
 10. Garantir l'employabilité des salariés de BIC

Un **COMPROMISO** de más de 10 AÑOS.

El enfoque de desarrollo sostenible en el Grupo BIC está basado en un conjunto de documentos que definen nuestra visión y configuran un marco para las actividades diarias de cada empleado, con el fin de garantizar el cumplimiento de los principios de desarrollo sostenible.

PROGRAMA DE DESARROLLO SOSTENIBLE BIC

En 2003, el Grupo definió el programa de desarrollo sostenible BIC. A través de este programa, el Grupo BIC busca:

- **Desarrollar el sentido común ecológico:** con el fin de limitar el consumo de recursos naturales, el Grupo se esfuerza en minimizar el uso de materias primas en sus productos y envasados, a la vez que introduce gradualmente nuevos materiales ecológicos, reciclados y renovables.
- **Reducir su impacto medioambiental:** porque BIC mide el impacto medioambiental de sus productos, fábricas y transportes y tiene una base para la implementación de acciones para reducir el impacto medioambiental.
- **Construir día a día las relaciones basadas en la confianza:** BIC también se preocupa de reforzar las habilidades y la ocupación de sus empleados y se esfuerza en mejorar la calidad de vida de sus puestos de trabajo, al tiempo que promueve iniciativas locales para dar apoyo a las comunidades.

LOS OBJETIVOS PARA EL GRUPO BIC ha identificado las principales cuestiones relacionadas con las fases clave de su negocio, desde la materia prima hasta la gestión del final de la vida útil de sus productos.

- COMPRAS
- PRODUCCIÓN
- DISTRIBUCIÓN
- USO
- FIN DE LA VIDA ÚTIL DEL PRODUCTO

Consulta el documento completo en www.bicgraphic.com

EL BARÓMETRO

BIC controla y evalúa el progreso de su programa de desarrollo sostenible a través del Barómetro BIC, el cual define 10 compromisos de desarrollo sostenible asociados a 10 indicadores de desempeño, y es actualizado cada tres años.

PRODUCTOS

1. Lanzar productos innovadores y responsables
 2. Crear productos para mercados emergentes
 3. Ofrecer productos BIC® con beneficios medioambientales
- INDUSTRIA
4. Selección responsable de materiales para el embalaje
 5. Mejorar la conducta medioambiental de las fábricas BIC
 6. Mantener un bajo nivel de transporte aéreo
- SOCIAL
7. Mantener un bajo número de accidentes de trabajo
 8. Intensificar la implementación del Código de Conducta del Grupo BIC
 9. Incentivar el compromiso de los empleados
 10. Garantizar la ocupación de los empleados

Seit über 10 JAHREN UNSERE VERPFLICHTUNG

Der Ansatz der BIC-Gruppe für eine nachhaltige Entwicklung ist in einem Dokumentensatz festgelegt, in dem wir unsere Vision definiert haben und jedem einzelnen Mitarbeiter einen Rahmen für seine tägliche Arbeit bieten, die die Erfüllung der Prinzipien einer nachhaltigen Entwicklung gewährleistet.

DAS BIC-PROGRAMM ZUR NACHHALTIGEN ENTWICKLUNG

Im Jahr 2003 legte die BIC-Gruppe die Bedingungen für das "Programm zur nachhaltigen Entwicklung" fest. Mithilfe dieses Programms will die BIC-Gruppe

- ein allgemeines ökologisches Bewusstsein schaffen, um den Verbrauch natürlicher Ressourcen zu begrenzen, die Verwendung von Rohstoffen in seinen Produkten und Verpackungen zu minimieren und gleichzeitig nach und nach umweltfreundliche, recycelte oder erneuerbare Materialien einzusetzen.
- die Umweltbelastung reduzieren: Weil BIC eine Messung der Umweltbelastung seiner Produkte, Fabriken und Transportmaßnahmen durchführt, wurde eine Grundlage geschaffen, anhand derer Maßnahmen zur Reduzierung der Umweltbelastung ergriffen werden können.
- immer wieder aufs Neue Beziehungen aufbauen, die auf Vertrauen basieren: BIC konzentriert sich auch darauf, die Fähigkeiten seiner Mitarbeiter und deren Beschäftigungsmöglichkeiten kontinuierlich zu stärken und die Lebensqualität am Arbeitsplatz zu verbessern und fördert zudem lokale Initiativen zur Unterstützung der Gemeinschaft.

ZIELSETZUNGEN FÜR DIE GRUPPE

BIC hat die wichtigsten Herausforderungen für die zentralen Phasen seiner Geschäftstätigkeit identifiziert, angefangen bei der Lieferung der Rohstoffe über den Einsatz bis hin zum Management der Lebensdauer seiner Produkte.

- EINKAUF
- PRODUKTION
- VERTRIEB
- GEBRAUCH
- ENDE DES PRODUKTLEBENSZYKLUSSES

Das komplette Dokument mit weiteren Einzelheiten finden Sie unter www.bicgraphic.com

DAS BAROMETER

BIC kontrolliert und bewertet die Fortschritte seines Programms zur nachhaltigen Entwicklung mithilfe des BIC-Barometers, in dem zehn unternehmenseigene Verpflichtungen zur nachhaltigen Entwicklung definiert sind, denen zehn Leistungsparameter zugrunde liegen und das alle drei Jahre aktualisiert wird.

PRODUKTE

1. Einführung innovativer, verantwortungsbewusster Produkte
2. Entwicklung von Produkten für Schwellenmärkte
3. Angebot von BIC®-Produkten mit Umweltnutzen

INDUSTRIE

4. Verantwortungsbewusste Auswahl von Verpackungsmaterialien
 5. Verbesserung der umweltorientierten Leistung der BIC-Fabriken
 6. Aufrechterhaltung einer niedrigen Luftfrachtquote
- SOZIAL / GESELLSCHAFTLICH
7. Erhalt einer geringen Arbeitsunfallsquote
 8. Intensivere Umsetzung des Verhaltenskodexes der BIC-Gruppe
 9. Förderung des Mitarbeiter-Engagements
 10. Sicherstellung der Beschäftigungsfähigkeit der BIC-Mitarbeiter

Un **IMPEGNO** di oltre 10 ANNI

L'approccio allo sviluppo sostenibile del Gruppo BIC si basa su una serie di documenti che definiscono la nostra visione e offre un quadro all'interno del quale ogni dipendente svolge le proprie mansioni quotidiane, così da assicurare la piena conformità ai principi della sostenibilità.

IL PROGRAMMA DI SVILUPPO SOSTENIBILE BIC

Nel 2003, il Gruppo ha definito il Programma di Sviluppo Sostenibile BIC. Attraverso questo programma il Gruppo BIC vuole:

- **sviluppare una sensibilità ecologica collettiva:** al fine di limitare il proprio consumo di risorse naturali, il Gruppo si impegna a ridurre al minimo l'utilizzo di materie prime in prodotti e imballaggi, introducendo gradualmente al tempo stesso nuovi materiali ecologici, riciclati o rinnovabili.
- **ridurre il proprio impatto ambientale:** la valutazione dell'impatto ambientale di prodotti, stabilimenti e attività di trasporto è per BIC una piattaforma utile per implementare iniziative volte alla riduzione dell'impatto ambientale.
- **consolidamento di rapporti quotidiani basati sulla fiducia:** Altro importante obiettivo di BIC è quello di rafforzare le competenze e l'occupabilità dei dipendenti e migliorare la qualità di vita sul luogo di lavoro, promuovendo al tempo stesso iniziative locali per il sostegno alle comunità.

I PUNTI CRUCIALI PER IL GRUPPO BIC ha individuato i punti cruciali legati alle fasi chiave della propria attività, dalla fornitura di materie prime, all'utilizzo del prodotto fino alla gestione del prodotto non più utilizzato.

- ACQUISTO
- PRODUZIONE
- DISTRIBUZIONE
- UTILIZZO
- FINE CICLO DEL PRODOTTO

Consulta il documento completo su www.bicgraphic.com

IL BAROMETRO

BIC dirige e valuta il progresso del proprio Programma di Sviluppo Sostenibile con il Barometro BIC che definisce dieci impegni di sviluppo sostenibile associati ad altrettanti indicatori di prestazione e viene aggiornato ogni tre anni.

PRODOTTI

1. Lanciare prodotti innovativi ed ecologici
 2. Creare prodotti per i mercati in espansione
 3. Offrire prodotti BIC® con vantaggi ambientali
- INDUSTRIA
4. Selezionare materiali ecologici per l'imballaggio
 5. Migliorare le prestazioni degli stabilimenti BIC in materia ambientale
 6. Mantenere un basso livello di trasporto aereo
- SOCIALE / AZIENDALE
7. Mantenere un basso numero di infortuni sul lavoro
 8. Intensificare l'attuazione del Codice di Condotta del Gruppo BIC
 9. Sviluppare il coinvolgimento dei dipendenti
 10. Assicurare l'occupabilità dei dipendenti BIC

Sustainable Development: our commitment



BIC Group's sustainable development approach is based on a set of documents that define our vision and provide a framework for each employee's everyday activities in order to ensure compliance with the principles of sustainable development.

THE BIC SUSTAINABLE DEVELOPMENT PROGRAMME



In 2003, the Group defined the BIC Sustainable Development Programme. Through this Programme, the BIC Group seeks to:

- **develop ecological common sense:** in order to limit its consumption of natural resources, the Group strives to minimise the use of raw materials in its products and packaging, while gradually introducing new eco-friendly, recycled or renewable materials.
- **reduce its environmental impact:** because BIC measures the environmental impact of its products, factories and transport activities, it has a basis for implementing actions to reduce the environmental impact.
- **build day-to-day relationships based on trust:** BIC also focuses on strengthening employee skills and employability and on improving quality of life in the workplace, while promoting initiatives that support local communities.



THE ISSUES FOR THE GROUP

BIC has identified the main issues related to the key phases of its business, from the supply of raw materials to the use of the product and to its end-of-life management.

- | | | |
|--|--|--|
| <p>PURCHASING</p>  | <p>The supply of raw materials that are used to make BIC® products</p> <ul style="list-style-type: none"> • 45.6% of the Group's purchasing concern plastics | <ul style="list-style-type: none"> • Reduce consumption of non-renewable raw materials • Promote the use of alternative materials (recycled or plant-derived) • Ensure suppliers' compliance with environmental, social and governance standards |
| <p>PRODUCTION</p>  | <p>The manufacture of BIC® products in the Group's factories or by contract manufacturers</p> <ul style="list-style-type: none"> • 46 million products sold every day worldwide | <ul style="list-style-type: none"> • Reduce water and energy consumption • Reduce CO₂ emissions and wastes • Reduce our impact on biodiversity • Maintain good working conditions for our employees • Ensure respect for Human Rights • Strive to develop employees' skills • Promote diversity in the company |
| <p>DISTRIBUTION</p>  | <p>The shipping of BIC® products by transport service providers</p> <ul style="list-style-type: none"> • 0.592 teqCO₂ per tonne of freight | <ul style="list-style-type: none"> • Optimise shipments and distribution routes • Ensure responsible distribution adapted to local conditions |
| <p>USAGE</p>  | <p>The use of BIC® products (writing instruments, lighters, shavers, etc.)</p> <ul style="list-style-type: none"> • An average of 3 km of writing for a BIC® Cristal pen • Up to 3,000 flames for a BIC® Maxi lighter • Up to 17 shaves for a BIC® Flex 3 | <ul style="list-style-type: none"> • Guarantee long-lasting products (stationery, lighters, shavers, promotional products) • Ensure the quality and safety of products • Promote responsible consumption • Anticipate customers' and consumers' needs • Reduce packaging waste |
| <p>END OF LIFE</p>  | <p>The elimination of BIC® products</p> <ul style="list-style-type: none"> • Weight of a BIC® Cristal pen: 5.9 g • Weight of a BIC® Maxi lighter: 21.8 g • Weight of a BIC® 3 shaver: 8.8 g | <ul style="list-style-type: none"> • Help reduce the overall quantity of waste produced • Investigate possible recovery and recycling solutions |

THE BAROMETER

BIC pilots and evaluates the progress of its Sustainable Development Programme using the BIC Barometer, which defines ten sustainable development commitments associated with ten performance indicators. The BIC Barometer is updated every three years.

Products

1. Launch innovative responsible products
2. Create products for developing markets
3. Offer BIC® products with environmental benefits



Industry

4. Select responsible materials for packaging
5. Improve the environmental performance of BIC factories
6. Maintain a low level of air freight



Social / Societal

7. Maintain low worker accident rates
8. Intensify the implementation of the BIC Group Code of Conduct
9. Develop employees engagement
10. Ensure BIC employees employability



FR > La sécurité des produits : une priorité fondamentale

Tous nos produits sont sûrs, conformes à la législation et socialement responsables. Plus de 60 années d'expérience dans la fabrication de produits BIC® garantissent la sécurité et la conformité de tous nos produits.

✓ Contrôlés par des spécialistes de la sécurité des produits

Tous nos produits sont contrôlés par des spécialistes de la sécurité des produits.

✓ Conformes aux normes de sécurité relatives aux capuchons

Tous les instruments d'écriture sont conformes aux normes de sécurité relatives aux capuchons.

✓ EN 13869

Tous les briquets BIC® vendus dans l'UE sont conformes à la norme EN 13869 relative aux briquets de sécurité enfants*.

✓ Absence de plomb

Produits testés pour s'assurer de l'absence de plomb et d'autres métaux lourds.

✓ Approuvés par un toxicologue

Les encres présentes dans tous les instruments d'écriture ont été approuvées par un toxicologue du Centre médical de la Duke University, dans le cadre du programme de certification de la WIMA (Writing Instrument Manufacturers Association) ou de l'ACMI (Arts & Creative Materials Institute).

✓ ISO 9994

Tous les briquets de poche BIC® respectent les spécifications de la norme internationale de qualité ISO 9994 ou vont au-delà.

PARTENAIRES EN MATIÈRE DE SÉCURITÉ DES PRODUITS ET DE RESPONSABILITÉ SOCIÉTALE

• SGS

• Bureau Veritas

• Membre de SEDEX et audité SMETA, une organisation sans but lucratif visant à promouvoir les améliorations responsables et éthiques au niveau des pratiques en vigueur au sein des chaînes d'approvisionnement.

EXEMPLE DE CONFORMITÉ

PRODUIT : BIC® Round Stic®

- Métaux lourds tels que le cadmium, conformément à l'alinéa 23 du règlement REACH concernant les substances extrêmement préoccupantes, testé selon la norme EN 1122
- Directive 2001/95/CE relative à la sécurité générale des produits
- ISO 11540 (BS 7272-1) – capuchons d'instruments pour l'écriture et le marquage
- ISO 11540 (BS 7272) – capuchons d'instruments pour l'écriture et le marquage
- Règlement REACH (CE) n° 1907/2006
- Directive 1999/45/CE – classification, emballage et étiquetage des préparations dangereuses (encres)
- Règlement 1272/2008 – classification, étiquetage et emballage des substances et des mélanges (encres)

* Un briquet "sécurité-enfants" n'est pas un briquet exempt de tout risque pour les enfants: c'est un briquet que 85% au moins des enfants de moins de 51 mois ne peuvent pas faire fonctionner

ES > La seguridad en nuestros productos: una prioridad fundamental

Todos nuestros productos son seguros, cumplen con la ley y son socialmente responsables. Los más de 60 años de experiencia en la fabricación de productos BIC® son garantía de seguridad y de conformidad de todos nuestros productos.

✓ Revisado por especialistas en seguridad

Todos los productos son revisados por un especialista en seguridad.

✓ Aprobación de medidas de seguridad del capuchón y del botón

Todos los Instrumentos de Escritura cumplen con la normativa de capuchón y botón.

✓ EN 13869

Todos los encendedores BIC® vendidos en Europa cumplen con la normativa EN 13869 Child Resistance*.

✓ Análisis de plomo

Incluye pruebas para medir el contenido de plomo y de otros metales pesados.

✓ Aprobado por toxicólogos

Las tintas utilizadas en todos los instrumentos de escritura están aprobadas por un toxicólogo de la Duke University Medical Center bajo el criterio de la WIMA (Writing Instrument Manufacturers Association) o el programa de certificación de ACMI (Arts & Creative Materials Institute).

✓ ISO 9994

Todos los Encendedores de bolsillo BIC® cumplen o exceden los estándares y especificaciones de seguridad internacional ISO 9994.

SOCIOS PARA LA SEGURIDAD DE LOS PRODUCTOS Y LA RESPONSABILIDAD SOCIAL

• SGS

• Bureau Veritas

• Miembros de SEDEX y auditados bajo auditoría SMETA, una organización sin ánimo de lucro dedicada a liderar mejoras en prácticas de ética y responsabilidad empresarial en cadenas de suministro globales.

EJEMPLO DE CONFORMIDAD DE PRODUCTO: BIC® Round Stic®

- Metales pesados como el Cadmio según la lista de REACH 23 SVHC, probado según EN 1122
- Directiva 2001/95/EC sobre la seguridad general de los productos.
- ISO 11540 (BS 7272-1) – capuchones de productos de escritura y de marcado
- ISO 11540 (BS 7272) – El botón de los productos de escritura y de marcado.
- Reglamento REACH (CE) n°1907/2006
- Directiva 1999/45 CE – la clasificación, envasado y etiquetado de preparados peligrosos (tintas).
- Reglamento 1272/2008 – clasificación, envasado y etiquetado de sustancias y mezclas (tintas)

* Un encendedor Child-resistant es un encendedor que por lo menos el 85% de los niños menores de 51 meses de edad no pueden accionar.

DE > Produktsicherheit: Von fundamentaler Priorität

Alle unsere Produkte sind sicher, erfüllen alle gesetzlichen Anforderungen und sind sozialgerecht. Die über sechzigjährige Erfahrung in der Herstellung von BIC®-Produkten bürgt für die Sicherheit und Konformität aller unserer Erzeugnisse.

✓ Überprüft durch Produktsicherheits-Experten

Alle Produkte werden von einem Produktsicherheitsexperten geprüft.

✓ Sicherheitsstandards für obere und untere Verschlusskappen

Alle Schreibgeräte erfüllen die Sicherheitsstandards für obere und untere Verschlusskappen.

✓ EN 13869

Alle in der EU verkauften BIC®-Feuerzeuge erfüllen die Bestimmungen der EN 13869-Norm zur Kindersicherheit*.

✓ Auf Blei getestet

Beinhaltet Tests auf Bleigehalt und andere Schwermetalle.

✓ Durch Toxikologen genehmigt

Alle in den Schreibgeräten verwendeten Tinten werden durch einen Toxikologen des Duke University Medical Centers gem. Zertifizierungsprogramm des WIMA (Writing Instrument Manufacturers Association) oder des ACMI (Arts & Creative Materials Institute) genehmigt.

✓ ISO 9994

Alle BIC®-Taschenfeuerzeuge erfüllen die Spezifikationen des internationalen Sicherheitsstandards ISO 9994 oder übertreffen diese sogar.

PARTNER FÜR PRODUKTSICHERHEIT UND SOZIALE VERANTWORTUNG

• SGS

• Bureau Veritas

• Stolztes SEDEX-Mitglied und SMETA-geprüft, eine gemeinnützige Organisation, die sich für die Verbesserung verantwortungsvoller und ethischer Geschäftspraktiken in globalen Lieferketten einsetzt.

BEISPIEL FÜR PRODUKTKONFORMITÄT: BIC® Round Stic®

- Schwermetalle, wie Kadmium, gem. Eintrag 23 der Kandidatenliste der REACH-Verordnung für besonders besorgniserregende Stoffe (engl.: SVHC), getestet gem. EN 1122.
- Richtlinie 2001/95/EC zur allgemeinen Produktsicherheit
- ISO 11540 (BS 7272-1) – Verschlusskappen für Schreibgeräte und Marker
- ISO 11540 (BS 7272) – untere Verschlusskappen für Schreibgeräte und Marker
- REACH-Verordnung (EC) Nr. 1907/2006
- Richtlinie 1999/45/EC – Klassifizierung, Verpackung und Etikettierung gefährlicher Präparate (Tinten).
- Bestimmung 1272/2008 – Klassifizierung, Verpackung und Etikettierung von Substanzen und Mixturen (Tinten)

* Ein kindersicheres Feuerzeug ist ein Feuerzeug, das mind. 85 % der Kinder unter 51 Monaten nicht bedienen können

IT > Sicurezza dei prodotti: una priorità assoluta

Tutti i nostri prodotti sono sicuri e conformi alla legge e alle norme sociali.

L'esperienza di oltre 60 anni nella realizzazione di prodotti BIC® garantisce la sicurezza e la conformità di tutti i nostri prodotti.

✓ Controllati da specialisti in sicurezza dei prodotti

Tutti i prodotti sono controllati da uno specialista in sicurezza dei prodotti.

✓ Soddisfano le norme di sicurezza sulla chiusura del cappuccio

Tutti gli strumenti di scrittura soddisfano le norme di sicurezza sulla chiusura del cappuccio.

✓ EN 13869

Tutti gli accendini BIC® venduti nell'UE sono conformi alla normativa EN 13869 sulla sicurezza dei bambini*.

✓ Testati per la presenza di piombo

Incluse test per la presenza di piombo e altri metalli pesanti.

✓ Approvati da un tossicologo

Gli inchiostri in tutti gli strumenti di scrittura sono approvati da un tossicologo del Duke University Medical Center all'interno del programma di certificazione WIMA (Writing Instrument Manufacturers Association) o ACMI (Arts & Creative Materials Institute).

✓ ISO 9994

Tutti gli accendini tascabili BIC® soddisfano o superano i requisiti delle norme internazionali di sicurezza ISO 9994.

PARTNER PER LA SICUREZZA DEI PRODOTTI E LA RESPONSABILITÀ SOCIALE

• SGS

• Bureau Veritas

• Membro di SEDEX e sottoposto a revisioni da parte di SMETA, un'organizzazione senza scopo di lucro impegnata nel miglioramento delle pratiche commerciali etiche e responsabili all'interno delle catene di fornitura globale.

ESEMPIO DI CONFORMITÀ DEL PRODOTTO: BIC® Round Stic®

- Metalli pesanti quali cadmio secondo voce 23 dell'elenco SVHC del REACH, testato a norma EN 1122
- Direttiva 2001/95/CE sulla sicurezza generale dei prodotti
- ISO 11540 (BS 7272-1) – cappucci di strumenti di scrittura
- ISO 11540 (BS 7272) – chiusure estremità di strumenti di scrittura
- Regolamento REACH (CE) n°1907/2006
- Direttiva 1999/45/CE – classificazione, imballaggio ed etichettatura di preparati pericolosi (inchiostri)
- Regolamento 1272/2008 – classificazione, imballaggio ed etichettatura di sostanze e miscele (inchiostri)

* Un accendino a prova di bambino è un dispositivo che almeno l'85% dei bambini di età inferiore a 51 mesi non è in grado di far funzionare.

Product Safety:

a fundamental priority

All our products are safe, legally and socially compliant.

The more than 60 years of experience manufacturing BIC® products guarantees the safety and compliance of all our products.

✓ **Reviewed by Product Safety Specialists**



- All products are reviewed by a **product safety specialist**.

✓ **Pass Cap and End Closure Safety Standards**



- All writing instruments comply with the **cap and end closure safety standards**.

✓ **EN 13869**



- All BIC® lighters sold in the European Union comply with the **EN 13869 Child Resistance regulation***.

✓ **Tested for Lead**



- Includes tests for lead and other heavy metals.

✓ **Approved by a Toxicologist**

- Inks used in **all Writing Instruments** are approved by a toxicologist at Duke University Medical Center under the Writing Instrument Manufacturers Association (**WIMA**) or the Arts & Creative Materials Institute (**ACMI**) Certification Programme.



✓ **ISO 9994**

- All BIC® pocket lighters meet or exceed the international safety specifications of the **ISO 9994** standard.

PARTNERS FOR PRODUCT SAFETY AND SOCIAL COMPLIANCE

• **SGS**



• **Bureau Veritas**



- Proud member of **SEDEX and SMETA** audited, a non-profit membership organisation dedicated to driving improvements in responsible and ethical business practices in global supply chains.



EXAMPLE OF PRODUCT COMPLIANCE: Round Stic®

Heavy metals such as Cadmium on the entry **23 SVHC List of REACH**, tested under EN 1122

Directive **2001/95/EC** on general product safety

ISO 11540 (BS 7272-1) – writing and marking instrument caps

ISO 11540 (BS 7272)
- writing and marking instrument end closures

REACH Regulation (EC) n°1907/2006

Directive **1999/45/EC** - classification, packaging and labelling of dangerous preparations (inks)

Regulation **1272/2008** - classification, packaging and labelling of substances and mixtures (inks)



* A Child-resistant lighter is a lighter that at least 85% of children under the age of 51 months cannot operate.

FR >  : un bon rapport qualité/prix

- **Le saviez-vous ?**
Vous pouvez appuyer **10 000 fois** sur votre BIC® Media Clic ! Une performance exceptionnelle soutenue par la Politique de performance produits du groupe BIC.
- **Clip**
Conçu pour supporter un **pois de 6,8 kg sans casser**. Un stylo à bille durable pour un impact de marque tout aussi durable !
- **Bouton**
Personnalisez le bouton dans la couleur de **vos** logo.
- Mécanisme **fiable** de rétraction grâce au poussoir.
- **Mine**
La mine des stylos BIC® Media Clic est fabriquée en France.
- **Mix & Match**
Le stylo BIC® Media Clic est disponible dans **plus de 10 000 combinaisons de couleurs de corps et d'attributs** ! Mélangez et combinez les couleurs pour compléter votre logo !
- **Encre longue durée**
Encre à base d'huile. Séchage rapide et écriture souple, de grande qualité. Writes the first time, every time® !
- **Corps**
Les composants fabriqués dans l'UE sont assemblés et décorés dans nos installations européennes.
- **BIC®, expert en instruments d'écriture**
Ajoutez de la valeur à vos cadeaux grâce à une marque leader à l'échelle mondiale.
- Le stylo BIC® Media Clic est l'instrument promotionnel d'écriture par excellence. C'est notre numéro un, **l'original** ! De multiples possibilités d'impression sur le corps et sur le clip, et des **milliers de combinaisons de couleurs**. Notre **best-seller** !

ES >  : buena relación calidad-precio

- **¿Sabías que...?**
¡Puedes pulsar tu BIC® Media Clic **10.000 veces!** Es un rendimiento de alta calidad respaldado por la Política de calidad y funcionamiento del Grupo BIC.
- **Clip**
Diseñado para soportar hasta **6,8 kg de fuerza sin romperse**. Un bolígrafo de larga duración para un impacto de marca de larga duración.
- **Botón**
Personaliza el botón del pulsador con el color que mejor combine con **tu logotipo**.
- Mecanismo retráctil **fiable**.
- **Cartucho**
El cartucho de un BIC® Media Clic se fabrica internamente, en Francia.
- **Mix & Match**
¡El bolígrafo BIC® Media Clic ofrece más de **10.000 combinaciones de color de atributos y cuerpo!** ¡Mezcla y combina colores para complementar tu logo!
- **Tinta de larga duración**
Tinta a base de aceite. De alta calidad, de secado rápido y de escritura suave. Writes the first time, every time®!
- **Cuerpo**
Los componentes fabricados en la UE se fabrican, se ensamblan y se decoran en nuestras instalaciones de la UE.
- **BIC®, el experto en Instrumentos de Escritura**
Añade valor a tu obsequio con una marca líder a nivel mundial.
- BIC® Media Clic es el instrumento de escritura de promoción por excelencia, nuestro número uno, **¡el original!** Múltiples posibilidades de impresión en el cuerpo y en el clip, y **miles de combinaciones de colores**. ¡Nuestro **n° 1 en ventas!**

DE >  : Ein gutes Preis-Leistungs-Verhältnis

- **Wussten Sie schon?**
Sie können **10.000 x auf** Ihren BIC® Media Clic drücken! Dies ist eine qualitativ besonders hochwertige Leistungsfähigkeit, die dank der Leistungs politik der BIC-Gruppe erzielt wurde.
- **Clip**
Dazu konzipiert, einem Druck von **6,8 kg standzuhalten, ohne zu zerbrechen**. Ein langlebiger Kugelschreiber für einen langlebigen Markeneindruck!
- **Druckknopf/Top-Button**
Gestalten Sie den Druckknopf ganz persönlich in der Farbe, die zu **Ihrem Logo passt**.
- **Zuverlässiger Druckmechanismus**.
- **Mine**
Die Mine in einem BIC® Media Clic wird im BIC®-Werk in Frankreich hergestellt.
- **Mix & Match**
Der BIC® Media Clic Druckkugelschreiber bietet **über 10.000 Farbkombinationsmöglichkeiten**
- **auf Schaft und Zierleisten!**
Mischen und kombinieren Sie die Farben, um Ihr Logo effektiv zu betonen!
- **Langlebige Tinte**
Tinte auf Ölbasis. Hochwertig, schnell trocknend, schreibt besonders leicht und weich. Writes the first time, every time®!
- **Schaft**
Die EU-gefertigten Bestandteile werden in unseren Fabriken in der EU hergestellt, zusammengesetzt und verziert.
- **BIC®, der Experte für Schreibgeräte**
Verleihen Sie Ihrem Geschenk einen ganz besonderen Mehrwert mit einer der weltweit führenden Marken .
- BIC® Media Clic ist das werbeträchtige Schreibgerät par excellence, unsere Nummer Eins, **das Original!** Vielfältige Bedruckungsmöglichkeiten auf Schaft und Clip und **Tausende von Farbkombinationen**. Unser **Best-Seller!**

IT >  : ottimo rapporto qualità/prezzo

- **Lo sapevi?**
Puoi premere il pulsante della tua BIC® Media Clic **10.000 volte!** Queste sono prestazioni di altissima qualità richieste dalla Politica sulle Prestazioni dei prodotti del Gruppo BIC.
- **Clip**
Progettata per resistere fino a **6,8 kg di forza senza spezzarsi**. Una penna a sfera di grande durata per un durevole impatto del marchio!
- **Pulsante**
Personalizza il pulsante con il colore abbinato **al tuo logo**.
- Meccanismo a scatto **affidabile**.
- **Cartuccia**
La cartuccia di una BIC® Media Clic è realizzata nei nostri stabilimenti in Francia.
- **Mix & Match**
La penna BIC® Media Clic offre più di **10.000 combinazioni di colori per finiture e fusto!**
- Mescola e abbinati i colori per accompagnare il tuo logo!
- **Inchiostro a lunga durata**
Inchiostro a base di olio. Scrittura di alta qualità, scorrevole e rapida nell'asciugarsi. Writes the first time, every time®!
- **Fusto**
I componenti prodotti nell'UE sono realizzati, assemblati e personalizzati nei nostri stabilimenti europei.
- **BIC®, l'esperto in strumenti di scrittura**
Aggiungi valore al tuo regalo con un marchio leader nel mondo.
- BIC® Media Clic è lo strumento di scrittura promozionale per eccellenza, il nostro numero uno, **l'originale!** Tante possibilità di stampa sul fusto e sulla clip e migliaia di combinazioni di colore. Il nostro prodotto **più venduto!**



BIC graphic: good value for money



BIC Media Clic

Did you Know?

You can click your BIC® Media Clic **10,000 times!**
This is high-quality performance backed by BIC Group's Product Performance Policy.



The BIC® Media Clic pen offers more than **10.000 trim and barrel colour combinations!**
Mix and match colours to complement your logo!

MIX & MATCH

Barrel

EU-made components are manufactured, assembled and decorated in our EU facilities.



Cartridge

The cartridge in a BIC® Media Clic is made in-house, in France.

Clip

Designed to withstand up to **6,8 kg of force without breaking.**
A long-lasting ballpoint for long-lasting brand impact!

Button

Customise the cover with the colour that matches **your logo.**

Reliable plunger action mechanism.

Long-life ink

Oil-based ink. High quality, quick drying and smooth writing. Writes the first time, every time®!



BIC®: the expert in Writing Instruments

Add value to your gift with a leading worldwide brand.

BIC® Media Clic is the promotional writing instrument of excellence, our number one, **the original!** Multiple printing possibilities on the barrel and on the clip, and **thousands of colour combinations.** Our **bestseller!**

FR >  : pionnier de l'impression numérique

- **Corps**
Nous réinventons le numérique :
d'impressionnants résultats, également sur les finitions translucides ! Impression photo couleur de haute qualité à **360° disponible sur tous les corps translucides.**
- **Clip**
- **Bouton**
Actualisez votre BIC® Wide Body™ avec le **nouvel attribut coloré chromé.**
- **10 années d'expérience**
Les premiers à introduire l'impression numérique sur un stylo.
- **Poussoir**
- **Bille résistante en carbure de tungstène**
La seule substance plus dure, c'est le diamant ! La bille parfaitement ronde en carbure de tungstène contribue à une écriture cohérente.
- **Section**
Également disponible en finition chromée.
- **Le saviez-vous ?**
Le stylo BIC® Wide Body™ Digital possède la **plus grande** surface d'impression du marché ! 107 mm x 35,5 mm !
- La totalité du corps du stylo BIC® Wide Body™ peut être imprimée en couleur. Agrémentez votre article promotionnel grâce une image de **qualité photographique en haute résolution à 360°**. Stylo à large profil promotionnel offrant un vaste éventail de possibilités d'impression et de finitions.

ES >  : el pionero en impresión digital

- **Cuerpo**
Reinventando la impresión Digital: ¡AHORA resultados impresionantes también en acabados frosted! Impresión **360° a todo color con calidad fotográfica** disponible en cualquier cuerpo frosted.
- **Sección**
También disponible en color cromado.
- **¿Sabías que...?**
¡BIC® Wide Body™ Digital tiene el área de impresión **más grande** del mercado! ¡107 mm x 35,5 mm!
- BIC® Wide Body™ cuenta con posibilidades de impresión a todo color y en todo su cuerpo. Envuelve tu promoción en **360° de alta resolución y calidad fotográfica**. Bolígrafo promocional de perfil ancho, con un gran abanico de acabados y posibilidades de impresión.
- **Clip**
- **Botón del pulsador**
Consigue un acabado más premium de tu BIC® Wide Body™ con los **nuevos atributos de color cromado.**
- **10 años de experiencia**
El primero en introducir la impresión Digital en un bolígrafo.
- **Pulsador**
- **Bola de carburo de tungsteno resistente**
¡La única sustancia más dura es el diamante! La bola

DE >  : Der Pionier im Digitaldruck

- **Schaft**
Neuerfindung des Digitalen: JETZT auch eindrucksvolle Ergebnisse in gefroreter Ausführung! **360° Fotoqualität in Vollfarbdruck** auf jedem gefrorenen Schaft möglich.
- **Clip**
- **Einsatz in der Verschlusskappe**
Werten Sie Ihren BIC® Wide Body™ mit dem **neuen chromfarbigen Ziereinsatz auf.**
- **10 Jahre Erfahrung**
Wir waren die ersten, die die digitale Drucktechnik auf einem Kugelschreiber eingeführt haben.
- **Druckmechanismus**
- **Langlebige Kugel aus Wolframkarbid**
Die einzige Substanz, die noch härter ist, ist der Diamant! Die perfekte, runde Hartmetallkugel aus Wolframkarbid fördert das gleichmäßige Schreiben.
- **Spitze**
Auch in chromfarbiger Ausführung erhältlich.
- **Wussten Sie schon?**
BIC® Wide Body™ Digital verfügt über die größte bedruckbare Fläche **auf dem Markt!** 107 mm x 35,5 mm!
- Bei BIC® Wide Body™ ist sowohl ein Vollfarb-, als auch ein Vollschaftdruck möglich. Verpacken Sie Ihre Werbung in einem **hochauflösenden 360°-Bild in Fotoqualität**. Kugelschreiber mit großflächigem Werbeprofil und einer großen Vielfalt an Finishes und Bedruckungsmöglichkeiten.

IT >  : un pioniere nella stampa digitale



- **Fusto**
Reinventare la stampa digitale: ADESSO risultati incredibili anche nelle finiture satinatè! Stampa a colori **di qualità fotografica a 360° disponibile** su qualsiasi fusto frosted.
- **Sezione**
Disponibile anche in finitura cromata colorata.
- **Lo sapevi?**
BIC® Wide Body™ Digital ha la **più ampia** area di stampa del mercato! 107 mm x 35,5 mm!
- BIC® Wide Body™ offre una stampa a colori sull'intero fusto. Avvolgi la tua promozione in un'**immagine ad alta risoluzione, di qualità fotografica a 360°**. Penna promozionale di ampio profilo con una vasta gamma di finiture e possibilità di stampa.
- **Clip**
- **Pulsante**
Rendi ancora più bella la tua BIC® Wide Body™ con la **nuova finitura cromata.**
- **10 anni di esperienza**
I primi a introdurre la stampa digitale su una penna.
- **Meccanismo a scatto**
- **Resistente sfera di carburo di tungsteno**
L'unica sostanza più dura è il diamante! La sfera perfettamente rotonda in carburo di tungsteno contribuisce a una scrittura di precisione.



BIC graphic: the pioneer in digital printing



BIC Wide Body™ Digital

Clip

Barrel

Reinventing the digital:

NOW impressive results in frosted finishes too! **360° photo-quality full-colour imprint** available on any frosted barrel.

Cover

Upgrade your BIC® Wide Body™ with the **new chrome-coloured trim.**



10 years of experience

The first to introduce Digital printing on a pen.

Plunger

Durable Tungsten Carbide Ball

The only substance harder is **diamond!** The perfectly spherical tungsten carbide ball contributes to consistent writing.



Did you Know?

BIC® Wide Body™ Digital has the **largest** printing area on the market! 107 mm x 35,5 mm!

Section

Also available in chrome-coloured finish.

BIC® Wide Body™ features a full-colour, full-barrel imprint. Wrap your promotion in a **360° high-resolution, photo-quality image.** Wide-profile promotional pen with a large variety of finishes and printing options.

FR >  **inventif**

- **Le saviez-vous ?**
Tous les produits et toutes les encres BIC® sont conformes aux lois et aux réglementations européennes et internationales les plus strictes en matière de sécurité. Confiez la promotion de **votre marque** aux produits d'une entreprise qui considère la sécurité comme une priorité fondamentale.
- **Capuchon**
Grande résistance, friction optimale sans blocage. **Mécanisme de rétraction fiable** : la mine ne se bloque pas.
- **Bague**
Faites-en un stylo encore plus fonctionnel en **ajoutant un tour de cou !** Voir pages 82 à 86
- Le logo BIC®, marque de confiance internationalement reconnue, est moulé sur le capuchon.
- **Corps**
Grande zone d'impression
4 couleurs de 43 mm x 30 mm.
- **Léger et durable**
Conçu et fabriqué en utilisant juste la quantité de matière première nécessaire pour un usage maximum. Contient l'encre de quatre mines, ce qui le rend encore plus durable.
- **Le saviez-vous ?**
Il vous suffit d'appuyer sur l'un des quatre boutons pour écrire dans la couleur de votre choix : **4 stylos en 1 !**
- **Une référence qui ne passe pas de mode.** Simple, fiable, inventive. Nous marquons la tendance du marché des instruments d'écriture depuis plus de 40 ans et continuons à croître.

ES >  **ingenioso**

- **¿Sabías que...?**
Todos los productos y tintas BIC® cumplen con las leyes y los estándares más estrictos de la UE y a nivel internacional. Promociona **tu marca** en un producto de una compañía donde la seguridad es una prioridad fundamental.
- **Capuchón**
Muy buena resistencia, buena fricción sin atascarse. **Mecanismo retráctil fiable**: los cartuchos no se bloquean.
- **Anilla**
¡Hazlo todavía más funcional **añadiendo un lanyard!** Mira en las páginas 82-86
- La internacionalmente reconocida marca de confianza BIC® viene moldeada en el capuchón.
- **Cuerpo**
Gran área de impresión
43 mm x 30 mm con posibilidad de **4 colores de impresión**.
- **Ligero y de larga duración**
Diseñado y fabricado con la cantidad justa de materia prima para un máximo uso. Contiene la tinta de cuatro cartuchos, lo que lo hace más duradero.
- **¿Sabías que...?**
Pulsando el botón del color que quieres, aparece el color que necesitas: azul, negro, rojo o verde. **¡4 bolígrafos en 1!**
- **Un icono que está siempre de moda.** Sencillo, fiable, ingenioso. Más de 40 años marcando tendencia en instrumentos de escritura, sin dejar de crecer año tras año.

DE >  **innovativ**

- **Wussten Sie schon?**
Alle BIC®-Produkte und -Tinten erfüllen selbst die strengsten EU- und internationalen Produktsicherheitsgesetze und -normen. Machen Sie Werbung für **Ihre Marke** mit dem Produkt eines Unternehmens, bei dem Sicherheit an oberster Stelle steht.
- **Verschlusskappe**
Sehr widerstandsfähig, guter Halt, aber kein Verklemmen. **Zuverlässiger Einzugsmechanismus**, die Minen blockieren sich nicht gegenseitig.
- **Ring**
Machen Sie ihn durch **Anbringung eines Schlüsselbandes (Lanyard)** sogar noch praktischer! Siehe Seiten 82-86
- Das international bekannte und vertraute BIC®-Markenlogo, findet sich als Relief auf der Verschlusskappe.
- **Schaft**
Großer Druckbereich von 43 mm x 30 mm und mit bis **zu 4 Farben bedruckbar**.
- **Leicht und langlebig**
Entworfen und hergestellt mit genau der richtigen Menge an Rohstoffen für maximalen Nutzen. Enthält vier vollständige Minen was die Lebensdauer deutlich erhöht.
- **Wussten Sie schon?**
Durch Drücken des entsprechenden Farbknopfes können Sie die gewünschte Farbe wählen: blau, schwarz, rot oder grün. **4 Kugelschreiber in 1!**
- **Eine Schreibikone, die immer in Mode ist!** Einfach, zuverlässig, einfallreich und originell. Seit über 40 Jahren Trendsetter bei Schreibgeräten, und wir wachsen von Jahr zu Jahr weiter.

IT >  **creativo**

- **Lo sapevi?**
Tutti i prodotti e gli inchiostri BIC® sono conformi alle più severe leggi e norme europee e internazionali sulla sicurezza dei prodotti. Promuovi il **tu marchio** su un prodotto di un'azienda per la quale la sicurezza è una priorità assoluta.
- **Cappuccio**
Ottima resistenza, buona frizione senza incastrarsi. **Meccanismo retrattile affidabile**: le cartucce non si bloccano.
- **Anello**
Rendila ancora più funzionale **aggiungendo un lanyard!** Vedi pagine 82-86
- Il logo del marchio BIC®, conosciuto e apprezzato in tutto il mondo, è stampato a rilievo sul cappuccio.
- **Fusto**
Ampla area di stampa (43 mm x 30 mm) e fino a **4 colori di stampa**.
- **Leggera e durevole**
Progettata e realizzata con la perfetta quantità di materie prime per l'utilizzo più intenso. Contiene l'inchiostro di scrittura di quattro cartucce per una maggiore durata.
- **Lo sapevi?**
Premendo il pulsante corrispondente scegli il colore che vuoi - blu, nero, rosso o verde. **4 penne in 1!**
- **Un'icona sempre alla moda.** Semplice, affidabile, fantasiosa. Per oltre 40 anni abbiamo dettato la moda nel campo degli strumenti di scrittura e continuiamo a crescere anno dopo anno.



BIC 4 Colours

Did you Know?

All BIC® products and inks comply with the strictest EU and international product safety laws and standards. Promote **your brand** on a product from a company where safety is a fundamental priority.

Cap

Very good resistance, good friction without wedging.
Reliable retracting mechanism: cartridges that do not block.

Ring

Make it even more functional by **adding a lanyard!**
See pages 82-86.

The internationally recognised and trusted BIC® brand logo is moulded onto the cap.



Light and Long-lasting

Designed and manufactured with just the right amount of raw materials for maximum use. Contains writing ink for four cartridges, making it last longer.

Barrel

Large printing area
43 mm x 30 mm and **up to 4 colours imprint.**

An icon that's always in fashion. Simple, reliable, inventive. More than 40 years setting the trend in writing instruments, and it keeps growing year after year.

Did you Know?

At the click of a colour-coded button, you select the colour you want: blue, black, red or green. **4 pens in 1!**

FR > : une qualité exceptionnelle

- **Le saviez-vous ?**
La marque BIC® est reconnue par 9 personnes sur 10. Votre nom sera associé à un **produit de confiance, de grande qualité.**
- **Clip**
Le clip du BIC® Grip Roller est en **caoutchouc texturé** pour une prise en main plus confortable.
- **Poussoir**
- **Grip**
Le grip du BIC® Grip Roller est en **caoutchouc texturé pour une prise en main plus confortable.**
- **Mine**
Système à encre fibreuse : l'encre est stockée dans une recharge et est libérée de façon efficace et constante à travers la pointe.
- **Encre**
Le BIC® Grip Roller contient de l'encre à séchage rapide à base d'eau pour une écriture **souple et précise.**
- Faites l'expérience d'une écriture **souple** et confortable. Glissez aisément sur la page, sans bavures, grâce à **l'encre à séchage rapide.** Idéal pour les gauchers comme pour les droitiers. Vous cherchez un roller de qualité ? Pas d'hésitation, choisissez le BIC® Grip Roller !

ES > : calidad a nivel mundial

- **¿Sabías que...?**
La marca BIC® es reconocida por 9 de cada 10 personas. Tu nombre se asociará con un **producto de confianza y de alta calidad.**
- **Tinta**
El BIC® Grip Roller contiene tinta de secado rápido a base de agua para una escritura **fluida y precisa.**
- Disfruta de una experiencia de escritura **fluida** y cómoda. Deslízalo fácilmente por la página sin mancharte gracias a la **tinta de secado rápido**, ideal para diestros y zurdos. ¡Cuando se trate de calidad en bolígrafos roller, se trata de BIC® Grip Roller!
- **Clip**
El clip del BIC® Grip Roller se fabrica con **níquel de alto grado** para prevenir la oxidación o deterioración.
- **Botón**
- **Grip**
El grip del BIC® Grip Roller está fabricado de **goma y presenta un cómodo relieve.**
- **Cartucho**
Sistema fibroso de tinta: la tinta se almacena en la espuma fibrosa y se libera a través de la punta con un rendimiento eficiente y consistente.

DE > : Qualität der Spitzenklasse

- **Wussten Sie schon?**
Die Marke BIC® ist 9 von 10 Personen bekannt. Ihre eigene Marke wird mit einem hochwertigen **Produkt assoziiert, dem man vertraut.**
- **Clip**
Der BIC® Grip Roller-Clip besteht aus **hochwertigem Nickel**, um Rost und Abnutzung vorzubeugen.
- **Druckmechanismus**
- **Griff**
Die Grifffläche eines BIC® Grip Rollers besteht aus **Gummi mit Reliefstruktur, die angenehm zu halten ist.**
- **Kartusche**
Faser-Tinten-System: Die Tinte ist in einer Mine gespeichert und wird durch die Spitze abgegeben, wodurch eine effizienteres, gleichmäßigeres Schreiben möglich wird.
- **Tinte**
Der BIC® Grip Roller enthält wasserbasierte, schnell trocknende Tinte für **gleichmäßiges, präzises Schreiben.**
- Freuen Sie sich auf ein **gleichmäßiges, angenehmes Schreiberlebnis.** Dank der **schnell trocknenden Tinte**, können Sie leicht und ohne zu schmieren über die Seiten gleiten. Sowohl für Rechts-, als auch für Linkshänder bestens geeignet. Wenn es um Qualitätstintenroller geht, ist der BIC® Grip Roller die erste Wahl!

IT > : qualità di livello mondiale

- **Lo sapevi?**
Il marchio BIC® è conosciuto da 9 persone su 10. Il vostro nome sarà associato a un **prodotto rinomato e di alta qualità.**
- **Inchiostro**
Il BIC® Grip Roller contiene inchiostro a base d'acqua a rapida essiccazione per una scrittura **scorrevole e precisa.**
- Sperimenta una scrittura **scorrevole** e comoda. Scivola agevolmente sulla pagina senza macchiare grazie all'**inchiostro a essiccazione rapida**, ideale per mancini e destri. Quando si parla di penne roller di qualità, si parla di BIC® Grip Roller!
- **Clip**
fermaglio di BIC® Grip Roller è realizzata in **nichel di grande qualità** per impedire ruggine o deterioramento.
- **Tappino**
- **Impugnatura**
L'impugnatura di un BIC® Grip Roller è realizzata in **comoda gomma antiscivolo.**
- **Cartuccia**
Sistema a inchiostro fibroso: L'inchiostro è immagazzinato in un filler e rilasciato attraverso la punta per una prestazione efficace e costante.



BIC graphic: world-class quality



BIC Grip Roller

Did you Know?

The BIC® brand is recognised by 9 out of 10 people. Your name will be associated with a **high-quality, trusted product.**



Grip

The grip on a BIC® Grip Roller is made of **comfortable, textured rubber.**



Cartridge

Fibrous Ink System:
The ink is stored in a filler and is released through the tip with efficient, consistent performance.

Ink

The BIC® Grip Roller contains water-based, fast-drying ink for **smooth, precise writing.**



Clip

The BIC® Grip Roller clip is made of **high-grade nickel** to prevent rust and deterioration.

Plunger

Enjoy a **smooth** and comfortable writing experience. Glide across the page easily without smudging thanks to the **quick-drying ink**, ideal for left-handed and right-handed people. When it comes to quality roller ball pens, it comes to BIC® Grip Roller!

FR > **graphic** : un choix durable

- **Le saviez-vous ?**
Le groupe BIC conçoit des produits fiables, de grande qualité, qui ne contiennent que les **composants essentiels**. Notre objectif est de réduire la quantité de matière première utilisée durant la production.
- **Attributs**
Attributs polis en nickel argenté
- **Mécanisme**
- **Bouton**
Disponible en **version argentée ou dorée**.
- **Poussoir**
- **Bague**
- **Plastique**
Le stylo BIC® Clic est composé de 26 % de plastique provenant d'une source renouvelable.
- **Comment faisons-nous**
Il s'agit de bois de conifères issus de **forêts gérées de façon durable**. L'écorce sert de carburant pour transformer les copeaux de bois en **plastique renouvelable**. Nous obtenons des pellets **pré-consommation en plastique recyclé**, qui sont utilisés pour fabriquer les stylos BIC® Ecolutions®.
- BIC Graphic est fier de proposer une gamme d'instruments d'écriture et d'articles de papeterie fabriqués avec des **matériaux recyclables ou des ressources renouvelables**.

DE > **graphic** : Eine nachhaltige Wahl

- **Wussten Sie schon?**
Die BIC-Gruppe entwickelt zuverlässige und hochwertige Produkte, die nur die **wesentlichen Komponenten** enthalten. Unser Ziel besteht darin, den Einsatz von Rohstoffen für die Produktion weitestgehend zu reduzieren.
- **Zierleiste**
Polierte, nickelbeschichtete Zierleiste.
- **Stopfen**
- **Druckmechanismus-Knopf**
Wählen Sie zwischen einem **silbernen oder einem goldenen Zierknopf**.
- **Druckmechanismus**
- **Ring**
- **Kunststoff**
Der BIC® Clic-Kugelschreiber besteht zu 26% aus Kunststoff aus erneuerbaren Ressourcen.
- **Woraus wird alles hergestellt?**
Das Holz stammt von Weichhölzern und aus **nachhaltiger Forstwirtschaft**. Die Rinde wird als Brennstoff verwendet, um aus Holzchips **Kunststoffe aus nachwachsenden, erneuerbaren Ressourcen** zu fertigen. Das Endergebnis sind **Pre-Consumer recycelte Plastik-Pellets**, aus denen die BIC® Ecolutions®-Stifte hergestellt werden.
- BIC Graphic ist stolz darauf, eine Palette an Schreibgeräten und Schreibwaren anbieten zu können, die aus recyceltem Material oder **erneuerbaren Ressourcen gefertigt werden**.

ES > **graphic** : una opción sostenible

- **¿Sabías que...?**
El Grupo BIC diseña productos fiables y de alta calidad que únicamente contienen los **componentes esenciales**. Nuestro objetivo es reducir la cantidad de materias primas utilizadas durante la producción.
- **Atributos**
Atributos bañados en níquel pulido.
- **Actuator**
- **Botón del pulsador**
Escoge entre **atributos de color plateados o dorados**.
- **Pulsador**
- **Anilla**
- **Plástico**
El BIC® Clic está fabricado con un 26% de plástico de fuentes renovables.
- **¿Cómo se hace?**
La madera se obtiene de coníferas y de **bosques gestionados de forma sostenible**. La corteza se utiliza como combustible para convertir las virtudes de madera en **plástico renovable**. El resultado final son **gránulos de plástico reciclado pre-consumo** para hacer bolígrafos BIC® Ecolutions®.
- BIC Graphic está orgulloso de ofrecer una amplia variedad de instrumentos de escritura y productos de papelería fabricados con **materiales reciclados o fuentes renovables**.

IT > **graphic** : una scelta sostenibile

- **Lo sapevi?**
Il Gruppo BIC progetta prodotti affidabili e di alta qualità che contengono solo i **componenti essenziali**. Il nostro obiettivo è quello di ridurre la quantità di materie prime consumate durante la produzione.
- **Finitura**
lucida, nichelata.
- **Azionatore**
- **Pulsante a scatto**
Scegli tra **finitura argentata o dorata**.
- **Meccanismo a scatto**
- **Anello**
- **Plastica**
La penna BIC® Clic è realizzata con il 26% di plastica proveniente da risorse rinnovabili.
- **Come è realizzata?**
Il legno proviene da foreste di **conifere gestite in maniera sostenibile**. La corteccia è utilizzata come carburante per trasformare la segatura in una **plastica rinnovabile**. Il risultato finale sono **grani di plastica riciclata** per la realizzazione delle penne BIC® Ecolutions®.
- BIC Graphic è orgogliosa di offrire un'ampia gamma di strumenti di scrittura e prodotti cartacei realizzati con materiali riciclati o risorse rinnovabili.



graphic: a sustainable choice



Clic



Trim

Polished, nickel-plated trim

Plunger Cover

Choose from silver or gold coloured trim.

Actuator

Plunger

Ring



Did you Know?

The BIC Group designs reliable, high-quality products that contain **only the essential components**. Our goal is to reduce the amount of raw materials used during production.



Plastic

The BIC® Clic Pen is made 26% plastic from renewable sources.

How is it made?



Wood is collected from softwood and **sustainably managed forests**.



Bark is used as fuel to convert the wood chips into a **renewable plastic**.



The final result is **pre-consumer recycled plastic pellets** used to make BIC® Ecolutions® pens.

BIC Graphic is proud to offer a range of writing instruments and paper products manufactured with **recycled materials or renewable resources**.

• Le saviez-vous ?

Les briquets BIC® assurent **deux fois plus d'allumages** que les autres briquets à pierre du même format*. Tous les briquets de poche BIC® sont fabriqués dans nos propres usines, avec des équipements d'assemblage en série de dernière génération.

• Protection

Dispositif de protection ajouté sur la molette de tous les briquets de sécurité enfants BIC®.

• Capot

En acier, il protège du vent et de la chaleur.

• Pierre

Un ressort presse la pierre contre la molette pour générer des étincelles.

• Tige

Le sous-ensemble tige/joint est soumis à un contrôle de qualité qui fait appel à un système sophistiqué de caméras.

• Molette

Lorsque l'on tourne la molette en fil d'acier trempé dentelé avec suffisamment de vitesse et de force, cela génère une étincelle.

• Fourchette**• Ressort de la fourchette**

Avec la tige et la fourchette, ces composants **contrôlent l'ouverture et la fermeture de la valve d'où provient le gaz.**

• Valve

Ce sous-ensemble régule le débit et libère un **flux régulier de gaz**, ce qui permet d'obtenir une **flamme constante**, d'une hauteur prédéfinie.

• Ressort de la pierre

Rapproche la pierre de la molette au fur et à mesure que la pierre s'use. Ce ressort applique une pression sur la pierre pour générer des étincelles.

• Corps et fond

Le corps, en plastique, est soudé par ultrasons sur le fond. Le corps, le fond et la bille forment le réservoir à gaz.

• Bille

Obtue le réservoir de gaz après remplissage.

Les briquets sont composés d'un réservoir de gaz inflammable sous pression et d'un générateur de flamme. Il est donc essentiel qu'ils soient conformes aux réglementations en vigueur en matière de sécurité, et il se trouve que c'est la priorité numéro un de BIC. **Tous les briquets de poche BIC® respectent les spécifications de la norme internationale de qualité ISO 9994** ou vont au-delà. Tous les briquets BIC® vendus dans l'UE sont conformes à la norme EN 13869 relative aux briquets de sécurité enfants.**

* Tests internes - marché UE 2008-2010 / pour le J26

** Un briquet "sécurité-enfants" n'est pas un briquet exempt de tout risque pour les enfants: c'est un briquet que 85% au moins des enfants de moins de 51 mois ne peuvent pas faire fonctionner

• ¿Sabías que...?

Los Encendedores BIC® ofrecen hasta el **doble de encendidos** que otros Encendedores del mismo formato*. El 100% de los Encendedores de bolsillo BIC® se fabrican en fábricas propias con equipos técnicos de ensamble de última generación.

• Seguro

Dispositivo de seguridad insertado en la moleta de todos los Encendedores BIC® con protección a prueba de niños.

• Protector de llama

En acero. Posee una función de protección contra el viento y el calor.

• Piedra

Contiene un elemento esencial para la moleta necesario para generar chispas. El muelle de la piedra ejerce una presión sobre ésta para producir las chispas.

• Moleta

Cuando la moleta fabricada con alambre de acero templado dentado gira con suficiente velocidad y fuerza, crea una chispa.

• Quemador

La calidad del subconjunto quemador - junta se comprueba mediante un **sofisticado sistema de visión por cámara.**

• Pulsador**• Muelle del pulsador**

El quemador y el muelle del pulsador **controlan la apertura y el cierre de la válvula de gas.**

• Válvula

El subconjunto regula el **flujo de gas** liberando un **nivel constante** que permite obtener una **llama continua** de una altura predeterminada.

• Muelle de la piedra

Proporciona a la moleta el material necesario a través de la piedra a medida que ésta se desgasta. El muelle de la piedra ejerce una presión sobre ésta para producir las chispas.

• Cuerpo y base

El cuerpo es de plástico, unido a la base mediante soldadura ultrasónica. El cuerpo, la base y la esfera constituyen el depósito de gas.

• Esfera

Sella el depósito de gas una vez lleno.

Un encendedor es un tanque de gas inflamable bajo presión y un generador de llama. Por ello, debe cumplir con las normas de seguridad en vigor, y la seguridad pasa a ser la prioridad número uno de BIC. **Todos los Encendedores de bolsillo de BIC® cumplen o exceden los estándares de seguridad internacionales ISO 9994.** Todos los Encendedores vendidos en la UE cumplen con la norma EN 13869 de seguridad para niños**.

* Tests internos - Mercado EU 2008-2010 / para J26

** Un encendedor a prueba de niños es aquel que asegura que al menos el 85% de los niños menores de 51 meses no pueden encenderlo.

• Wussten Sie schon?

BIC®-Feuerzeuge bieten **bis zu 2 x mehr Zündungen**, als andere Feuerzeuge gleicher Kategorie*. 100% der BIC®-Taschenfeuerzeuge werden in unseren eigenen Fabriken mit modernster Massenproduktions-Technologie gefertigt.

• Sicherheitsbügel

Bei allen kindersicheren BIC®-Feuerzeugen gibt es einen Sicherheitsbügel über dem Reibrad für den Zündfunken.

• Abdeckung

Stahl. Wind- und Hitzeschutz.

• Feuerstein

Ist das Material zur Funkenerzeugung. Die Feuersteinfeder übt Druck auf den Feuerstein aus, um so den Funken zu erzeugen.

• Reibrad

Wenn das Reibrad, das aus gezähntem, gehärtetem Stahldraht besteht, mit ausreichender Geschwindigkeit und Kraft gedreht wird, wird der Funke erzeugt.

• Jet-Flamme

Der Mechanismus der Jet-Flammen-/Kugeldichtung ist von hochwertiger Qualität, bei der ein ausgeklügeltes **Kameravisionssystem** eingesetzt wird.

• Gabel**• Gabelfeder**

Mit der Jet- und Gabelfeder wird das Öffnen und **Schließen des Gasflusses** aus dem Ventil kontrolliert.

• Ventil

Dieses Bauteil reguliert den **Gasfluss** so, dass immer die **gleiche Menge** an Flüssigkeit freigesetzt wird, damit eine **gleichmäßige Flamme** in voreingestellter Höhe brennt.

• Feuersteinfeder

Schiebt den Feuerstein zum Reibrad, da sich der Feuerstein abnutzt. Die Feuersteinfeder drückt gegen den Feuerstein, damit ein Funke erzeugt werden kann.

• Gehäuse und Boden

Das Gehäuse besteht aus Kunststoff, das mit Ultraschall an den Boden geschweißt wurde. Gehäuse, Boden und Versiegelungskugel bilden den Gasbehälter.

• Kugel

Verschließt den Gasbehälter, nachdem er gefüllt wurde.

Ein Feuerzeug ist ein unter Druck stehender, entflammbarer Gasbehälter, der eine Flamme erzeugt. Daher muss es die bestehenden Sicherheitsvorschriften erfüllen, und Sicherheit steht bei BIC immer an erster Stelle. **Alle BIC®-Taschenfeuerzeuge erfüllen bzw. übertreffen die internationalen Sicherheitsnormen gem. ISO 9994-Spezifikationen.** Alle in der EU verkauften BIC®-Feuerzeuge entsprechen der EN 13869-Richtlinie zur Kindersicherheit.**

*Interne Tests im europäischen Markt von 2008 -2010.

** Ein kindersicheres Feuerzeug ist ein Feuerzeug, das von mindestens 85% der Kinder unter 51 Monaten nicht bedient werden kann.

• Lo sapevi?

Gli accendini BIC® garantiscono fino al **doppio delle accensioni** rispetto agli altri accendini a pietra focaia dello stesso formato*. Il 100% degli accendini tascabili BIC® è realizzato nei nostri stabilimenti con attrezzature di assemblaggio all'avanguardia.

• Sicura

Sicura aggiunta sopra la rotella di accensione su tutti gli accendini BIC® a prova di bambino.

• Cappuccio

Acciaio. Parafiamma e protezione dal calore.

• Pietra focaia

Fornisce materiale per le scintille. La molla della pietra focaia applica pressione alla pietra per generare scintille.

• Rotella di accensione

Quando la rotella di accensione, in filo di acciaio temprato zigrinato, viene fatta ruotare con velocità e forza sufficienti genera una scintilla

• Ugello

Il sottogruppo ugello/sfera di tenuta è realizzato grazie a un **sofisticato sistema di visione a telecamere.**

• Levetta**• Molla della levetta**

L'ugello e la molla della levetta **controllano l'apertura e la chiusura del flusso di gas** proveniente dalla valvola.

• Valvola

Il sottogruppo regola il **flusso di carburante** e ne rilascia un **livello costante**, garantendo una **fiamma uniforme** di altezza prefissata.

• Molla della pietra focaia

Spinge la pietra focaia verso la rotella man mano che si consuma. La molla della pietra focaia applica pressione alla pietra per generare scintille.

• Corpo e base

Il corpo è realizzato in plastica, saldata alla base con ultrasuoni. Il corpo, la base e la sfera di tenuta compongono il serbatoio di gas.

• Sfera

Sigilla il serbatoio di gas una volta riempito.

Un accendino è un serbatoio di gas infiammabile sotto pressione con un generatore di fiamma. Per questo deve essere conforme alle norme vigenti sulla sicurezza, e la sicurezza è la priorità numero uno per BIC. **Tutti gli accendini tascabili BIC® soddisfano o superano i requisiti delle specifiche internazionali di sicurezza ISO 9994.** Tutti gli accendini BIC® venduti nell'UE sono conformi alla normativa EN 13869 sulla sicurezza dei bambini.**

* Verifica interna - Mercato UE 2008-2010 / su J26

** Un accendino a prova di bambino è un dispositivo che almeno l'85% dei bambini di età inferiore a 51 mesi non è in grado di far funzionare



BIC[®] graphic: product safety



Lighter



Did you Know?

BIC[®] lighters offer up to **twice the lights** than other flint lighters of the same format*. 100% of BIC[®] pocket lighters are made at our own factories with state-of-the-art mass assembly equipment.

Jet

The high-quality jet/globe seal subassembly uses a **sophisticated camera vision system**.

Valve

The subassembly regulates fuel flow and releases **a constant level of fuel**, for **a constant flame** of a predetermined height.

Ball

Seals the gas reservoir after it is filled.

Body and base

The body is made of plastic, that is **ultrasonically welded** to the base. The body, base and seal ball constitute the gas reservoir.

Flint

Supplies material for the spark. The flint spring applies pressure to the flint to generate a spark.

Hood
Steel. Windshield and heat protection.

Guard

A safety guard is added over the sparkwheel on all BIC[®] child-resistant lighters.

Spark wheel

When the spark wheel, made of serrated hardened steel wire, is rotated with sufficient speed and force, it creates a spark.

Fork Fork spring

The Jet and Fork Spring components **control the opening and closing of the gas valve**.

Flint spring

Feeds flint onto the spark wheel as the flint wears down. The flint spring applies pressure on the flint to generate a spark.

A lighter is a flammable gas tank under pressure and a flame generator. Therefore, it must comply with safety regulations in force and safety happens to be BIC's number one priority.

All BIC[®] pocket lighters meet or exceed the international safety standards ISO 9994 specifications. All BIC[®] lighters sold in the EU are conform

to the EN 13869 Child Resistance regulation.**

* Internal testing - EU Market 2008-2010 / on J26

** A Child-Resistant lighter is a lighter that cannot be operated by at least 85% of children under the age of 51 months.



With more than **45 years**

Stationery printing expertise

✓ **Leader** of promotional stationery products



Screen printing



3D puffy printing



Metallic inks



Laser engraving



Hot stamping



Debossing



4-colour process



britePix™



Digital

FR > **BIC graphic:**
expert en impression

La garantie de plus de **45 années** d'expérience !
Experts en **impression d'articles de papeterie**

- ✓ **Leader** des articles de papeterie promotionnels
- Sérigraphie
- Puffy printing
- Encres métalliques
- Gravure laser
- Estampage à chaud
- Gaufrage
- Quadrichromie
- britePix™
- Impression numérique

ES > **BIC graphic:**
experto en impresión

¡Con más de **45 años** de experiencia como garantía!
Expertos en **impresión en productos de Papelería**

- ✓ **Líder** en productos promocionales de papelería
- Serigrafía
- Impresión Puffy 3D
- Tintas metálicas
- Grabado en láser
- Hot stamping
- Termograbado
- Cuatricromía
- britePix™
- Digital

DE > **BIC graphic:**
Druckexperten

Mit über **45 Jahren** Erfahrung als Garantie!

Schreibwaren-Bedruckung:
Höchste Fachkompetenz

- ✓ **Leader** bei Schreibwaren der Werbeartikelbranche
- Siebdruck
- 3D Puffy-Druck
- Metallic-Tinten
- Lasergravur
- Heißprägung
- Blindprägung
- 4-Farbverfahren
- britePix™
- Digital

IT > **BIC graphic:**
esperti nella stampa

Con oltre **45 anni** di esperienza come garanzia!
Competenza nella **stampa su articoli di cancelleria**

- ✓ **Leader** in articoli di cancelleria promozionali
- Serigrafia
- Stampa 3D con inchiostro Puffy
- Inchiostri metallizzati
- Incisione laser
- Stampa a caldo
- Stampa a impressione
- Quadricromia
- britePix™
- Digitale

Expert

of experience as guarantee!

Full-Colour expertise

NEW FINISHES

NOW

DIGITAL PRINTING

ON ANY FROSTED OR OPAQUE BARREL ON SELECTED ITEMS

*Exact pantone colour match!**

Bringing your message to **life**

Revolutionary Concept

available on several surfaces and materials

* PMS SERVICE ≥10.000 u.

FR > Expertise couleur

NOUVEAUTÉ : IMPRESSION NUMÉRIQUE SUR TOUS LES CORPS TRANSLUCIDES OU OPAQUES POUR UNE SÉLECTION D'ARTICLES

- Correspondance exacte avec votre couleur PMS sur mesure!*

britePix™ Donnez de la vie à votre message!

- **Un concept révolutionnaire** disponible pour différentes surfaces et différents matériaux

* PMS SERVICE ≥10.000 ex.

ES > Expertos en impresión a todo color

AHORA IMPRESIÓN DIGITAL EN CUALQUIER COLOR DE CUERPO OPAO O FROSTED EN UNA SELECCIÓN DE PRODUCTOS.

- El color exacto de tu color PMS hecho a medida!*

britePix™ ¡Tu mensaje cobra vida!

- **Concepto revolucionario** disponible en una amplia gama de superficies y materiales

* SERVICIO PMS ≥10.000 u.

DE > Vollfarb-Fachkompetenz

JETZT AUCH DIGITALDRUCK AUF ALLEN GEFROSTETEN ODER OPAKEN GEHÄUSESCHÄFTEN AUF AUSGESUCHTEN ARTIKELN.

- Präzise Übereinstimmung mit Ihrer maßgefertigten PMS-Farbe (Pantone)*

britePix™ Verleihen Sie Ihrer Botschaft Leben!

- **Auf vielen Oberflächen** und Materialien erhältlich

* PMS SERVICE ≥ab 10.000 Stück

IT > Competenza nella stampa a colori

ORA STAMPA DIGITALE SU QUALSIASI FUSTO OPAO O FROSTED DEGLI ARTICOLI SELEZIONATI.

- Abbinamento perfetto con la personalizzazione del tuo colore PMS!*

britePix™ Il tuo messaggio prende vita!

- **Un concetto rivoluzionario** disponibile su una vasta gamma di superfici e materiali

* Pantone speciale ≥10.000 u.

With more than **45 years**

Lighter printing expertise

✓ **Make your brand stand out** with our range of printing techniques and finishes



Screen printing



Digital transfer



Pad printing



Laser engraving



britePix™



3D puffy printing



Metallic inks



NEW FINISHES

Digital

FR > **BIC graphic:**
expert en impression

La garantie de plus de **45 années** d'expérience !

Experts en **impression de briquets**

✓ **Faites ressortir votre marque**

grâce à notre gamme de finitions et de techniques d'impression

- Sérigraphie
- Transfert numérique
- Tampographie
- Gravure laser
- britePix™
- Puffy printing
- Encres métalliques
- Impression numérique

ES > **BIC graphic:**
experto en impresión

¡Con más de **45 años** de experiencia como garantía!

Expertos en **impresión en encendedores**

✓ **Haz que tu marca destaque** con

nuestra gama de técnicas y acabados

- Serigrafía
- Transfer digital
- Tampografía
- Grabado en láser
- britePix™
- Impresión Puffy 3D
- Tintas metálicas
- Digital

DE > **BIC graphic:**
Druckexperten

Mit über **45 Jahren** Erfahrung als Garantie!

Fachkompetenz **im Bedrucken von Feuerzeugen**

✓ **Verleihen Sie Ihrer Marke**

Aufmerksamkeit mit unserer breiten Palette an Drucktechniken und Ausführungen

- Siebdruck
- Digitale Übertragung
- Tampondruck
- Lasergravur
- britePix™
- 3D Puffy-Druck
- Metallic-Tinten
- Digital

IT > **BIC graphic:**
esperti nella stampa

Con oltre **45 anni** di esperienza come garanzia!

Competenza nella **stampa su accendini**

✓ **Metti in luce il tuo marchio** con

la nostra gamma di tecniche di stampa e finiture

- Serigrafia
- Trasferimento digitale
- Stampa a tampone
- Incisione laser
- britePix™
- Stampa 3D con inchiostro Puffy
- Inchiostri metallizzati
- Digitale

Expert

of experience as guarantee!



Enhance your brand with our new finishes and personalisation options!



NEW FINISHES

Now ALSO available in matte finish!

Digital Matte

Digital Brilliant



NEW FINISHES

H

Holographic

✓ Stand out from the crowd! Convert your logo into a three-dimensional image using holograms in the background or in different parts of the logo. Availability: February 2015



NEW FINISHES

M

Metallic

✓ Create great effects! Metallic effects in texts, images and backgrounds.

Now ALSO available in matte finish!

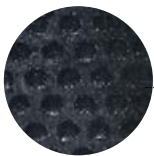

NEW FINISHES

PUFFY

Puffy printing

✓ Be original! Highlight your brand with our "Puffy" ink to give a relief effect to your logo.

FR > Donnez vie à votre briquet avec nos nouvelles finitions et options de personnalisation !
Impression numérique brillante / Impression numérique mate
Désormais ÉGALEMENT disponible en finition mate !
Holographique
✓ **Sortez du lot !** Transformez votre logo en image 3D grâce à des **hologrammes** imprimés à l'arrière-plan ou sur une partie de votre logo. Disponible à compter de février 2015.
Encre «puffy»
✓ Démarquez-vous ! Mettez l'accent sur votre marque avec notre **encre «puffy»**, qui donne du relief à votre logo.
Métallique
✓ Surprenant ! Un **effet métallique** sur les textes, les images ou l'arrière-plan.

ES > ¡Dale vida a tu encendedor con los nuevos acabados y opciones de personalización!
Digital brillante / Digital mate
¡Ahora TAMBIÉN disponible en acabado mate!
Holográfico
✓ **¡Destaca entre la multitud!** Convierte tu logo en una imagen tridimensional usando **hologramas** en el fondo del diseño y/o en algunas partes del logo. Disponible: Febrero 2015
Impresión Puffy
✓ ¡Sé único! Resalta tu marca con nuestra **tinta "Puffy"** dándole un efecto de relieve a tu logo.
Metalico
✓ ¡Crea efectos estupendos!
Efectos metálicos en los textos, imágenes o fondos del diseño.

DE > Verleihen Sie Ihrem Feuerzeug neues Leben mit neuen Ausführungs- und Personalisierungsoptionen!
Digital Brilliant / Digital Matt
Nun AUCH in matter Ausführung erhältlich!
Holographie
✓ **Heben Sie sich von der Masse ab!** Geben Sie Ihrem Logo ein dreidimensionales Erscheinungsbild durch **Verwendung von Hologrammen** als Hintergrund oder als Bestandteil Ihres Logos. Erhältlich ab Februar 2015.
Puffy Ink
✓ Seien Sie einzigartig!! Stellen Sie Ihre Marke mit unserer **"Puffy"-Tinte**, die Ihrem Logo einen Reliefeffekt verleiht, besonders heraus.
Metallic
✓ Erzielen Sie phantastische Effekte!
Metallic-Effekte in Texten, Bildern oder Hintergründen

IT > Dai vita al tuo accendino con nuove finiture e possibilità di personalizzazione!
Digitale brillante / Digitale opaco
Adesso disponibile ANCHE con finitura opaca!
Olografico
✓ **Fatti notare tra la folla!** Trasforma il tuo logo in un'immagine tridimensionale utilizzando **ologrammi** sullo sfondo o in alcune parti del logo. Disponibilità: febbraio 2015.
Inchiostro Puffy
✓ Sii unico! Sottolinea il tuo marchio con il nostro **inchiostro "Puffy"** che dona un effetto rilievo al tuo logo.
Metallizzato
✓ Crea effetti mai visti! **Effetti metallizzati** in testi, immagini o sfondi

FR > Service d'impression en 48 heures

GRATUIT pour plus de 100 produits !

Conditions préalables du programme

Instruments d'écriture

- Impression à 1 couleur (pour les produits métalliques, seule la gravure laser est disponible)

Sticky Note™

- 75 x 75 mm Adhesive Notepad (50 feuilles et papier standard)
- 101 x 75 mm Adhesive Notepad (50 feuilles et papier standard)

Briquets

- Impression à 1 couleur

Cases

- Impression à 1 couleur

Position de l'impression

- 1 position standard

Quantité maximale

- Quantité indiquée en bas de la colonne de la liste de prix, sauf bloc adhésif BIC® 75 mm x 75 mm et bloc adhésif BIC® 101 mm x 75 mm, disponibles jusqu'à 1.000 unités.

Pour les commandes en ligne :

- Le code promotionnel 90000480 doit être inclus dans le mot-clé.

Pays admis

- Pays de l'UE, Suisse et Norvège.

Détails supplémentaires du programme

- Dans le cas où l'article commandé n'est plus disponible en stock, nous vous offrons un

article alternatif d'une valeur égale ou supérieure. Dans ce cas, le délai de fabrication sera calculé à partir du moment où le client accepte l'article alternatif et approuve le nouveau design.

Conditions de la commande

- L'approbation du design doit être reçue par BIC Graphic Europe avant 12:00 GMT+1, du lundi au vendredi.
- Les fins de semaine et les jours fériés locaux d'Espagne ne sont pas considérés comme des jours ouvrables.

Expédition

- BIC Graphic Europe ne peut garantir une date spécifique de livraison, seule la date d'expédition est garantie.

Divers

- Modifications du design - Veuillez prévoir un temps supplémentaire pour les ajustements de design.
- Les comptes dont le crédit est gelé ne sont pas acceptés.
- Cette promotion n'est pas applicable aux commandes retardées par de mauvaises conditions atmosphériques, des catastrophes naturelles ou d'autres événements hors du contrôle raisonnable de BIC Graphic Europe.

ES > Servicio de impresión en 48 horas

¡GRATIS en más de 100 productos!

Requisitos del Programa Instrumentos de escritura

- Impresión a 1 color (para productos metálicos sólo impresión láser)

Sticky Note™

- 75 x 75 mm Adhesive Notepad (50 hojas y papel estándar)
- 101 x 75 mm Adhesive Notepad (50 hojas y papel estándar)

Encendedores

- Impresión a 1 color

Cases

- Impresión a 1 color

Posición a imprimir

- 1 posición standard

Cantidad Máxima

- Precio de última columna, excepto BIC® 75 mm x 75 mm y BIC® 101mm x 75 mm Adhesive Notepad, disponibles hasta 1.000 unidades.

Para pedidos on-line:

- El código promocional 90000480 debe incluirse en la palabra clave.

Países de Aplicación

- UE, Suiza y Noruega.

Detalles Adicionales del Programa

- En caso de no tener stock de los artículos solicitados, te ofreceremos un artículo alternativo de igual o superior valor. En este caso, el tiempo

de espera de producción se contará desde el momento en que el cliente acepte el producto alternativo y la nueva aprobación del diseño.

Requisitos del pedido

- Las aprobaciones de diseños deben ser recibidas por BIC Graphic Europe antes de las 12:00 p.m. GMT+1, de lunes a viernes.
- Fines de semana y festivos locales en España no se consideran días hábiles

Envío

- BIC Graphic Europe no puede garantizar una fecha de entrega específica, únicamente se puede garantizar nuestra fecha del envío.

Otros

- Cambios en diseños - Por favor, cuenta con un tiempo adicional para las correcciones de sus diseños.
- No aplicable en clientes con cuentas pendientes de pago.
- Promoción no aplicable en caso de fuerza mayor o cualquier otra situación fuera del control de BIC Graphic Europe

DE > 48-Stunden-Druckservice

KOSTENLOS bei mehr als 100 Produkten!

Programmanforderungen Schreibgeräte

- Einfarbiger Aufdruck (Bei Metallprodukten ist nur die Lasergravur möglich)

Sticky Note™

- 75 x 75 mm Haftnotizen (50 Blatt und Standardpapier)
- 101 x 75 mm Haftnotizen (50 Blatt und Standardpapier)

Feuerzeuge

- Einfarbiger Aufdruck

Boxen

- Einfarbiger Aufdruck

Aufdruckposition

- Eine Standardposition

Größtmögliche Menge

- Menge der letzten Spalte der Preisliste, mit Ausnahme von BIC® 75 mm x 75 mm Haftnotizen und BIC® 101mm x 75 mm Haftnotizen, erhältlich bis zu 1.000 Stück.

Für Online-Bestellungen:

- Der Werbecode 90000480 muss im Schlüsselwort mit inbegriffen sein.

In Betracht kommende Länder

- Länder der EU, die Schweiz und Norwegen.

Zusätzliche Programmdetails

- Im Falle, dass wir den Artikel Ihrer Bestellung nicht auf Lager haben, werden wir Ihnen einen alternativen Artikel mit dem gleichen oder einem höheren

Wert bieten. In diesem Fall wird die Fertigungsdurchlaufzeit von dem Moment an gezählt, ab dem der Kunde den alternativen Artikel sowie ebenfalls die neue Vorlagefreigabe akzeptiert hat.

Bestellungsanforderungen

- Die Freigabe der Vorlage muss bei BIC Graphic Europe um 12:00 P.M. GMT+1, von Montag bis Freitag eingehen.
- Wochenenden und lokale spanische Feiertage werden nicht als Werkstage anerkannt.

Versand

- BIC Graphic Europe kann kein spezifisches Lieferdatum garantieren; es ist nur das Versanddatum garantiert.

Sonstiges

- Änderungen der Vorlage - Bitte, geben Sie uns etwas zusätzliche Zeit für Anpassungen an der Vorlage.
- Kreditkonten sind nicht zulässig.
- Diese Promotion gilt nicht für Bestellungen mit Verzögerungen aufgrund von schwierigen Wettersituationen, Naturkatastrophen oder jedweden anderen Umständen, die sich außerhalb der Kontrollreichweite von BIC Graphic Europe bewegen.

IT > Servizio di stampa in 48 ore

GRATIS su oltre 100 prodotti!

Condizioni del programma Strumenti di scrittura

- Stampa a 1 colore (per i prodotti in metallo disponibile solo incisione laser)

Sticky Note™

- 75 x 75 mm Adhesive Notepad (50 fogli e carta standard)
- 101 x 75 mm Adhesive Notepad (50 fogli e carta standard)

Accendini

- Stampa a 1 colore

Copriaccendini

- Stampa a 1 colore

Posizione di stampa

- 1 posizione standard

Quantitativo massimo

- Quantitativo ultima colonna del listino prezzi, tranne che per blocco note adesivo BIC® 75 mm x 75 mm e blocco note adesivo BIC® 101 mm x 75 mm, disponibili fino a 1.000 unità.

Per ordini online:

- Il codice promozionale 90000480 deve essere incluso nella parola chiave.

Paesi che possono accedere all'offerta

- Paesi UE, Svizzera e Norvegia.

Ulteriori dettagli

- In caso di esaurimento dell'articolo ordinato, ti offriamo un articolo alternativo di valore equivalente o superiore. In questo caso il tempo di produzione sarà calcolato

dal momento in cui il cliente ha accettato l'articolo alternativo e approvato la nuova grafica.

Requisiti dell'ordine

- L'approvazione della grafica deve essere ricevuta da BIC Graphic Europe entro le ore 12:00 p.m. GMT+1, da lunedì a venerdì.
- Fine settimana e festività locali spagnole non sono considerati giorni lavorativi.

Spedizione

- BIC Graphic Europe non può garantire una data specifica di consegna, solo la data di spedizione.

Altro

- Modifiche della grafica - si prega di concedere tempi più lunghi per gli adeguamenti della grafica.
- Non applicabile a clienti con sospensione del credito.
- Questa promozione non si applica a ordini ritardati da condizioni meteorologiche avverse, disastri naturali o altri eventi al di fuori del ragionevole controllo di BIC Graphic Europe.

48-hour printing service

FREE ON OVER 100 PRODUCTS!



48h
PRINTING
SERVICE
FREE

Programme Requirements

Writing instruments

- 1-colour imprint (For metal products only)
Laser engraving available)

Sticky Note™

- 75 x 75 mm Adhesive Notepad (50 sheets and standard paper)
- 101 x 75 mm Adhesive Notepad (50 sheets and standard paper)

Lighters

- 1-colour imprint

Cases

- 1-colour imprint

Imprint position

- 1 standard position

Maximum Quantity

- Price List End Column Quantity, except BIC® 75 mm x 75 mm Adhesive Notepad and BIC® 101 mm x 75 mm Adhesive Notepad, available up to 1.000 units.

For online orders:

- The promotional code **90000480** must be included in the key word

Eligible Countries

- EU countries, Switzerland and Norway

Additional Programme Details

- In the event that we are out of stock of the item ordered, an alternative item of equal or greater value will be offered. In this case the production lead time will be counted from when the customer has accepted the alternative item and also the new artwork approval.

Order Requirements

- Artwork approval must be received by BIC Graphic Europe by 12:00 p.m. GMT+1, Monday to Friday.
- Weekends and local Spanish holidays are not considered as working days

Shipping

- BIC Graphic Europe cannot guarantee a specific delivery date; only shipping dates are guaranteed.

Other

- Artwork Changes - Please allow additional time for artwork adjustments.
- Accounts on credit hold are not eligible.
- This promotion does not apply to orders delayed by forces or major events beyond BIC Graphic's control.



PLASTIDECOR®



Quality inspires Creativity

BIC® Kids crayons are designed to enhance child development and creativity from the age of 2 years.

PLASTIDECOR®

Extra clean and resistant crayon, perfect for learners and part of every child's essential pencil case.



From learning to creating

Focused on the needs of young children who are just discovering colouring, but also ideal for older kids who frequently use colouring products at school and at home.

FR > BIC® Kids Plastidecor®, la couleur au quotidien !

- **La qualité inspire la créativité**
Les cires BIC® Kids sont conçues pour favoriser le développement et la créativité des enfants âgés de 2 ans et plus.
- **PLASTIDECOR®**
Cires très propres et très résistantes, idéales pour les apprentis dessinateurs et indispensables dans la trousse de tous les enfants.
- **De l'apprentissage à la création**
Centrées sur les besoins des plus petits qui découvrent le coloriage, mais aussi idéales pour les enfants plus âgés qui utilisent fréquemment des articles de coloriage à la maison et à l'école.
- **Sécurité produits**
Conformes à la norme européenne EN 71 relative à la sécurité des jouets et testées chaque année par un laboratoire indépendant. Fabriquées dans l'une des usines françaises de BIC pour en garantir la qualité, la traçabilité et la sécurité.
- **Le saviez-vous ?**
Les cires BIC® Kids sont recommandées par 9 mamans sur 10 !
- **Le cadeau idéal pour les enfants**
Les cires BIC® Kids Plastidecor® sont idéales pour occuper les enfants, quel que soit l'endroit où vous vous trouvez : au restaurant, en avion, à l'hôtel, à l'hôpital, etc.

La gamme BIC® Kids vous propose un vaste éventail de produits de coloriage de grande qualité, spécialement conçus pour les jeunes enfants, à partir de 2 ans. Elle accompagne tous les stades de développement de l'enfant, de l'apprentissage à la création.

Vous trouverez la gamme de BIC® Kids Plastidecor® aux pages 98-99

ES > ¡BIC® Kids Plastidecor®, colorea cada día!

- **Calidad inspira Creatividad**
Las ceras BIC® Kids están diseñadas para mejorar el desarrollo y la creatividad de niños a partir de 2 años.
- **PLASTIDECOR®**
La cera extra limpia y resistente, es ideal para los aprendices más pequeños y parte indispensable en el estuche de cualquier niño
- **Desde aprender hasta crear**
Centrado en las necesidades de los más pequeños, quienes están aprendiendo a colorear, pero también ideal para niños más mayores que pintan frecuentemente tanto en el colegio, como en casa.
- **Seguridad**
Cumple con la normativa europea estándar del juguete (EN71), es testado anualmente por un laboratorio independiente y es producido en una de las fábricas BIC en Francia. Todo ello, para asegurar la calidad, trazabilidad y seguridad.
- **Sabías que...? ;**
BIC® Kids es recomendado por 9 de cada 10 madres!*
- **El regalo ideal para niños**
BIC® Kids Plastidecor® es ideal para mantener a los niños entretenidos donde quiera que te encuentres: en el restaurante, en el avión, en el hotel, en el hospital, etc.

BIC® Kids ofrece una completa gama de productos para colorear de alta calidad, específicamente diseñados para niños desde la temprana edad de 2 años, y que les acompañan en todas las etapas de su desarrollo desde el aprendizaje hasta la creatividad.

Encuentra la gama BIC® Kids Plastidecor® en las páginas 98-99

DE > BIC® Kids Plastidecor®, Machen jeden Tag bunt!

- **Qualität inspiriert Kreativität**
BIC® Kids-Wachsmalkreiden wurden dazu konzipiert, die Entwicklung und Kreativität von Kindern ab einem Alter von 2 Jahren zu fördern.
- **PLASTIDECOR®**
Besonders saubere und widerstandsfähige Wachsmalkreiden, ideal für Schüler geeignet und wichtiger Bestandteil jedes Kinderschreibmappchens.
- **Vom Lernen zum Gestalten**
Insbesondere für die Bedürfnisse der kleinsten Kinder entwickelt, die gerade erst lernen, zu malen, aber auch ideal für ältere Kinder, die sowohl in der Schule, als auch zu Hause häufig Malfarben verwenden.
- **Produktsicherheit**
Erfüllt die europäische Spielzeugnorm (EN71) und wird jedes Jahr von einem unabhängigen Labor getestet. Hergestellt in einer der BIC-Fabriken in Frankreich zwecks Gewährleistung der Qualität, Rückverfolgbarkeit und Sicherheit.
- **Wussten Sie schon?**
Neun von zehn Müttern empfehlen BIC® Kids.
- **Das ideale Geschenk für alle Kinder**
BIC® Kids Plastidecor® ist das ideale Spielzeug, um Kinder sinnvoll zu beschäftigen, wo auch immer Sie sich gerade aufhalten: im Restaurant, im Flugzeug, im Hotel, im Krankenhaus etc.

BIC® Kids bietet eine vollständige Palette hochwertiger Erzeugnisse für den Malbedarf. Die Produkte wurden speziell für Kinder ab dem frühen Alter von 2 Jahren entwickelt und begleiten sie bei all ihren Entwicklungsschritten vom Lernen zum eigenständigen Gestalten.

Die Produktpalette von BIC® Kids Plastidecor® finden Sie auf den Seiten 98-99

IT > BIC® Kids Plastidecor®, colorare tutti i giorni!

- **La qualità ispira creatività**
I pastelli a cera BIC® Kids sono ideati per favorire lo sviluppo e la creatività del bambino a partire dai 2 anni di età.
- **PLASTIDECOR®**
Un pastello assolutamente pulito e resistente, perfetto per le prime esperienze nel disegno e parte essenziale dell'astuccio di qualsiasi bambino.
- **Dall'apprendimento alla creatività**
Attento alle esigenze dei bambini più piccoli che si avvicinano per la prima volta al mondo dei colori, ma ideale anche per i più grandi che li utilizzano spesso a scuola e a casa.
- **Sicurezza dei prodotti**
Soddisfa la norma europea sui giocattoli (EN71), testato annualmente da un laboratorio indipendente e prodotto in uno degli stabilimenti BIC in Francia per garantire qualità, tracciabilità e sicurezza.
- **Lo sapevi?**
BIC® Kids è consigliato da 9 mamme su 10!
- **Il regalo ideale per i bambini**
BIC® Kids Plastidecor® è ideale per far divertire i bambini in qualunque situazione: al ristorante, in aereo, in albergo, in ospedale, ecc.

BIC® Kids offre una gamma completa di prodotti per colorare di alta qualità, concepiti specificamente per bambini a partire da soli 2 anni di età, che accompagnano tutte le fasi dello sviluppo, dall'apprendimento alla creatività.

Trovi la gamma BIC® Kids Plastidecor® alle pagine 98-99

everyday colouring!

NEW

Product safety

Compliant with European toy standard (EN71), tested annually by an independent laboratory, and produced at one of the BIC factories in France to ensure quality, traceability and safety.

Did you Know?



Recommended by 9/10 mothers!*

The ideal gift for kids

BIC® Kids Plastidecor® is ideal for keeping children entertained wherever you are: at a restaurant, on the plane, at the hotel, in the hospital, etc.



BIC® Kids offers a full range of high-quality colouring products specially designed for children from the very early age of 2 years, to accompany all stages of the development of the child from learning to creating.

Find the BIC® Kids Plastidecor® range on pages 98-99

* Source: Harris Interactive Research Dec 2010 report.



SHEAFFER®

The Gift



Sheaffer® Prelude® Collection

Comfortable and balanced profile.
Sheaffer® Limited Lifetime
Warranty.



Did you Know?

A globally recognised trademark that is a symbol of writing excellence, the Sheaffer® White Dot® is featured on all Sheaffer® writing instruments.



Sheaffer® Taranis®

The design and finishes provide the balance between the classic and the modern. The gripping section combines the warmth of resin and the durability of metal.

FR > Sheaffer®.

Un cadeau qui marque

- **Collection Sheaffer® Prelude®**
Conjugué confort et équilibre. Garantie Sheaffer® limitée à vie.
- **Sheaffer® Taranis®**
Le design s'allie aux finitions pour atteindre un équilibre idéal entre le classique et le moderne. Le grip breveté combine la chaleur de la résine et la durabilité du métal.
- **Le saviez-vous ?**
Symbole reconnu de l'excellence en matière d'écriture, le point blanc Sheaffer® figure sur tous les instruments d'écriture de la marque.
- **Sheaffer® 500**
Instrument magnifiquement stylé et finement équilibré, offrant une écriture souple et un grand confort. Garantie Sheaffer® limitée 1 an.
- **Sheaffer® Sentinel® Colours**
profil mince coloré pour une correspondance parfaite avec votre marque. Garantie Sheaffer® limitée 1 an.
- **Collection Sheaffer® Stylus**
Une option idéale pour une transition sans heurts entre les écrans tactiles capacitifs et le papier. Le choix parfait pour une double expérience.

Sheaffer® crée depuis plus de 100 ans des produits stylés, fiables et innovants, avec un savoir-faire incomparable et une élégance sans faille.

Vous trouverez la gamme complète de produits Sheaffer® aux pages 114 à 143

ES > Sheaffer®.

El regalo que importa

- **Colección Sheaffer® Prelude®**
Perfil cómodo y equilibrado. Garantía Sheaffer® de por vida.
- **Sheaffer® Taranis®**
Diseño y acabados ideales, el equilibrio entre lo moderno y lo clásico. Grip patentado que combina la calidez de la resina con la durabilidad del metal.
- **¿Sabías que...?**
El punto blanco Sheaffer®, reconocido símbolo de marca registrada de escritura por excelencia, preside todos los instrumentos de escritura Sheaffer®.
- **Sheaffer® 500**
Diseño bello, finamente equilibrado que ofrece una confortable y escritura fluida. Garantía Sheaffer® limitada 1 año
- **Sheaffer® Sentinel® Colours:**
Perfil delgado de colores variados ideal para combinar con tu marca. Nuevos colores disponibles. Garantía Sheaffer® de 1 año.
- **Colección Sheaffer® Stylus**
La opción para una escritura fluida entre pantallas capacitivas y papel. La elección para una experiencia dual inteligente.

Sheaffer® cuenta con más de 100 años de tradición, creando productos estilosos, fiables e innovadores con una artesanía sin igual y diseños elegantes.

Encuentra la gama completa de productos Sheaffer® en las páginas 114 a 143

DE > Sheaffer®. Ein wirklich bedeutendes Geschenk

- **Sheaffer® Prelude® Collection**
Komfortables und wohlausgewogenes Profil. Eingeschränkte lebenslange Sheaffer®-Garantie.
- **Sheaffer® Taranis®**
Design und Ausführungen erzielen eine perfekte Ausgewogenheit zwischen klassisch und modern. Patentierter Griff, bei dem die Wärme von Harz und die Dauerhaftigkeit von Metall miteinander kombiniert wurden.
- **Wussten Sie schon?:**
Als weltweit bekanntes Markensymbol für hervorragenden Schreibkomfort findet sich der Sheaffer® White Dot® auf allen Sheaffer®-Schreibgeräten.
- **Sheaffer® 500**
Wunderschön gestaltetes, fein ausbalanciertes Schreibgerät, das ein komfortables, weichfließendes Schreibergebnis garantiert. Eingeschränkte Sheaffer®-Garantie: 1 Jahr.
- **Sheaffer® Sentinel® Colours:**
Farbenfrohes, schlankes Profil, das perfekt zu jeder Marke passt. Eingeschränkte Sheaffer®-Garantie: 1 Jahr
- **Sheaffer® Stylus Collection**
Die richtige Wahl für den nahtlosen Gebrauch als Schreibgerät für kapazitive Touchscreen-Geräte und Papier. Die richtige Wahl für eine intelligente Erfahrung mit dualen Nutzen.

Sheaffer® kann auf eine über 100-jährige Tradition in der Gestaltung styliher, zuverlässiger und innovativer Produkte von unvergleichlicher Kunstfertigkeit in elegantem Design zurückblicken.

Die vollständige Sheaffer®-Produktpalette finden Sie auf den Seiten 114-43

IT > Sheaffer®.

Il regalo che conta

- **Collezione Sheaffer® Prelude®**
Profilo confortevole e bilanciato. Garanzia a vita Sheaffer®.
- **Sheaffer® Taranis®**
Il design e le finiture rendono ideale l'equilibrio tra classico e moderno. La sezione dell'impugnatura brevettata unisce il calore della resina alla resistenza del metallo.
- **Lo sapevi?**
Marchio commerciale riconosciuto a livello mondiale e simbolo di eccellenza nella scrittura, il bollino Sheaffer® White Dot® è presente su tutti gli strumenti di scrittura Sheaffer®.
- **Sheaffer® 500**
Strumento dalle linee eleganti, finemente bilanciato che offre un'esperienza di scrittura comoda e scorrevole. Garanzia limitata di 1 anno Sheaffer®.
- **Sheaffer® Sentinel® Colours:**
Profilo sottile e colorato per un abbinamento perfetto al marchio. Garanzia limitata di 1 anno Sheaffer®.
- **Collezione Sheaffer® Stylus**
La scelta ideale per passare agilmente dai dispositivi touchscreen alla carta e viceversa. La scelta intelligente per una duplice esperienza.

Sheaffer® vanta oltre 100 anni di tradizione nel creare prodotti raffinati, affidabili e innovativi dall'ineguagliabile fattura e dal design elegante.

Trovi la gamma completa di prodotti Sheaffer® da pagina 114 a 143

That Matters

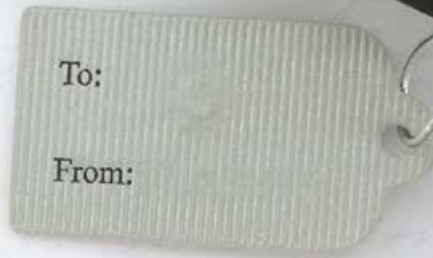

Scan this page,
live the BIC Graphic
Augmented Reality
experience and
share it!

**NEW
COLOURS**

Sheaffer® 500

A beautifully styled, finely balanced instrument that provides a smooth, comfortable writing experience. Sheaffer® Limited 1 Year Warranty.



**NEW
COLOURS**

Sheaffer® Sentinel® Colours

Colourful slim profile for great brand matching. Sheaffer® Limited 1 Year Warranty.



Sheaffer® Stylus Collection

The choice for a seamless transition between capacitive touchscreen devices and paper. The choice for a smart dual experience.



Sheaffer® has over 100 years of heritage, creating stylish, reliable and innovative products with unsurpassed craftsmanship and elegant designs.

Find the full Sheaffer® product range on pages 114 to 143



BIC® ecolutions®: our range of

BIC® Ecolutions® Round Stic®

With opaque and frosted barrel



BIC® Ecolutions® Wide Body™ family

The largest printing area
on the market!



NEW
COLOUR

BIC® Ecolutions® Media Clic

Now in black.
Up to 700 Mix&Match
possibilities!



FR > BIC® Ecolutions®: notre gamme de produits à caractère écologique

- BIC® Ecolutions® Round Stic®
Corps opaque ou translucide
- Gamme BIC® Ecolutions® Wide Body™
La plus grande zone d'impression du marché!
- BIC® Ecolutions® Media Clic
Nouvelle couleur : noir. Jusqu'à 700 possibilités de Mix&Match!
- Gamme BIC® Ecolutions® Evolution :
Sans bois. Pas d'échardes s'il se casse.
- Gamme BIC® Ecolutions® Clic
Fabriqué avec 26% de matériaux issus de sources renouvelables.
- BIC® Ecolutions® Sticky Note™
Tous les produits BIC® Ecolutions® Sticky Note™ sont fabriqués avec du papier de constitué de 100 % de fibres recyclables et un adhésif à base d'eau.
- BIC® Ecolutions® Permanent Marker
Écrit sur pratiquement toutes les surfaces. Grande zone d'impression.

La responsabilité et l'engagement du Groupe BIC à diminuer l'impact environnemental de ses produits constituent une part importante de son programme de développement durable. BIC Graphic Europe traduit cet engagement à travers une ligne de produits qui comprend des instruments d'écriture et des articles en papier fabriqués avec des matériaux recyclables ou des ressources renouvelables.

Vous trouverez la gamme BIC® Ecolutions® aux pages 176 à 195

ES > BIC® Ecolutions®: nuestra gama de productos con beneficios ecológicos

- BIC® Ecolutions® Round Stic®
Con cuerpos opacos y frosted
- Familia BIC® Ecolutions® Wide Body™
¡El área de impresión más grande del mercado!
- BIC® Ecolutions® Media Clic
Nuevo color negro. ¡Hasta 700 posibilidades Mix&Match!
- Familia BIC® Ecolutions® Evolution:
Sin madera, no se astilla al romperse.
- Familia BIC® Ecolutions® Clic
El BIC® Clic está fabricado con un 26% de plástico de fuentes renovables.
- BIC® Ecolutions® Sticky Note™
Todos los productos BIC® Ecolutions® Sticky Note™ están hechos con papel de fibra 100% reciclado y adhesivo a base de agua.
- BIC® Ecolutions® Permanent Marker
Escribe prácticamente en todas las superficies. Gran área de impresión.

La responsabilidad y el compromiso para minimizar el impacto en el medio ambiente, son una parte importante del programa de desarrollo sostenible del grupo BIC. BIC Graphic Europe demuestra este compromiso con una línea de productos incluyendo instrumentos de escritura y productos de papel fabricados con material reciclado o recursos renovables.

Encuentra la gama completa de BIC® Ecolutions® en las páginas 176 a 195

DE > BIC® Ecolutions®: Unsere Produktpalette mit ökologischem Nutzen

- BIC® Ecolutions® Round Stic®
Mit opaken und gefrostetem Schaft
- BIC® Ecolutions® Wide Body™-Produktkategorie
Die größte bedruckbare Fläche auf dem Markt!
- BIC® Ecolutions® Media Clic
Neue schwarze Farbe: Bis zu 700 Mix&Match-Möglichkeiten!
- BIC® Ecolutions® Evolution-Produktfamilie: Holzfrei und splitterfrei bei Bruch.
- BIC® Ecolutions® Clic-Produktfamilie
Material stammt zu 26% aus erneuerbaren Ressourcen
- BIC® Ecolutions® Sticky Note™
Alle BIC® Ecolutions® Sticky Note™-Produkte werden aus Papier hergestellt, das zu 100% aus recycelten Fasern und wasserbasierten Klebstoffen besteht.
- BIC® Ecolutions® Permanent Marker
Schreibt auf praktisch allen Oberflächen. Große Druckfläche.

Verantwortung und Engagement zur Minimierung der Auswirkungen auf die Umwelt sind ein wichtiger Bestandteil des Nachhaltigkeits-Entwicklungsprogramms der BIC-Gruppe. BIC Graphic Europe beweist dieses Verantwortungsbewusstsein mit einer Produktreihe, zu der Schreibgeräte und Papierwaren gehören, die aus recycelten Materialien oder erneuerbaren Ressourcen hergestellt sind.

Die Produktpalette von BIC® Ecolutions® finden Sie auf den Seiten 176-195

IT > BIC® Ecolutions®: la nostra gamma di prodotti dai vantaggi ecologici

- BIC® Ecolutions® Round Stic®
Con fusto opaco e frosted
- Famiglia BIC® Ecolutions® Wide Body™
La più ampia area di stampa del mercato
- BIC® Ecolutions® Media Clic
Nuovo colore nero. Fino a 700 possibilità Mix&Match!
- Famiglia BIC® Ecolutions® Evolution:
Senza legno né schegge in caso di rottura.
- Famiglia BIC® Ecolutions® Clic
Fabbricato con il 26% di materiali derivati da risorse rinnovabili.
- BIC® Ecolutions® Sticky Note™
Tutti i prodotti BIC® Ecolutions® Sticky Note™ sono realizzati in carta semplice contenente il 100% di fibra riciclata e adesivo a base d'acqua.
- Pennarello indelebile BIC® Ecolutions®:
Scrivo praticamente su qualsiasi superficie. Ampia area di stampa.

Responsabilità e impegno nel ridurre al minimo l'impatto ambientale costituiscono una parte importante del programma di sviluppo sostenibile del Gruppo BIC. BIC Graphic Europe dimostra tale impegno con una linea di prodotti che include strumenti di scrittura e prodotti cartacei realizzati con materiali riciclati o risorse rinnovabili.

Trovi la gamma BIC® Ecolutions® da pagina 176 a 195

products with ecological benefits



BIC® Ecolutions® Evolution family
Wood-free and splinter-free in case of breaking.



NEW COLOURS



BIC® Ecolutions® Sticky Note™
All BIC® Ecolutions® Sticky Note™ products are made of paper stock containing 100% recycled fibre and water-based adhesive.



BIC® Ecolutions® Clic family
The BIC® Clic is made of 26% plastic from renewable sources.



BIC® Ecolutions® Permanent Marker

Writes on virtually any surface. Large imprint area.



Responsibility and commitment to minimise environmental impact are an important part of BIC Group's sustainable development programme. BIC Graphic Europe demonstrates this commitment with a line of products including writing instruments and paper products manufactured with recycled materials or renewable resources.

Find the full BIC® Ecolutions® range on pages 176 to 195

FR > Guide des symboles et abréviations

Options spéciales

- Puffy printing**
Une personnalisation soulignée par notre encre « Puffy », pour donner un effet de relief à votre logo.
 - 4-colour process**
Permet la reproduction d'images de haute résolution. Idéal pour la reproduction de photographies. Original et attrayant
 - Encre métallique**
Modernisez votre message en ajoutant des encres métalliques d'impression, sans frais. Disponible en bleu, vert et rose.
 - Digital transfer**
Idéal pour reproduire des photographies, logos ou des images digitales sur briquets
 - Digital**
Quadrichromie haute définition. à 360° degrés et sur toute la longueur du corps du crayon.
 - britePix™**
Votre message peut maintenant être imprimé en quadrichromie et d'une excellente qualité image afin de produire une impression durable, vibrante et persistante de votre logo.
 - Finition métallique**
Crée des effets métalliques sur les images ou l'arrière-plan. Votre marque prendra une dimension exceptionnelle !
 - Finition holographique**
Transforme votre logo en image 3D grâce à des hologrammes. Pour un message à couper le souffle !
- Modes d'écriture**
- | | |
|-----------------|-------------------------|
| • Bille | • Crayon |
| • Stylo Plume / | • Stylo à bille roulant |
| • Surligneur | • Gel |
| • Marqueur | • Feutre pointe fine |
| • Porte-mine | |
- Couleurs d'encre**
- | | |
|---------|---------------------|
| • Noir | • Rose |
| • Bleu | • Bleu ultramarin |
| • Rouge | • Vert acide |
| • Vert | • Rose très féminin |
| • Jaune | • Pourpre sombre |
- BIC® Easy-Glide system option**
Offre une encre qui est 35 % plus lisse et plus épaisse que votre stylo à bille actuel.

Autres symboles

- Mix&Match**
Des centaines de couleurs de composants en stock pour la personnalisation complète des instruments d'écriture
- PMS Service**
Choisissez la couleur PMS pour des décorations les mieux adaptées à votre logo
- 48 hour**
Service 48 h disponible

- Mobius loop**
Le produit contient des matériaux recyclés.
- Renewable Resource**
Produit fabriqué avec des matériaux respectant l'environnement, utilisant des matériaux renouvelables de conifères (polymères cellulosiques).
- AZ antimicrobial**
L'additif antimicrobial est une composition chimique qui réduit l'augmentation de bactéries, algues, de champignons et de moisissures sur le stylo.
- Pays d'origine**
- Nouveautés 2015 / Nouveaux coloris 2015 / Nouveaux rendus / Nouvelles couleurs d'encre**
- EN 13869**
Règlement de sécurité des enfants pour les briquets
- ISO 22702**
Cette norme certifie la qualité de tous les briquets à usages multiples.
- ISO 9994**
Normes de sécurité internationales pour les briquets.
- Cabin friendly**
Cette icône identifie les produits qui correspondent à la taille limite de bagage cabine pour la plupart des compagnies aériennes
- Laptop**
Les produits indiqués par cette icône sont destinés à transporter et à protéger un ordinateur portable.
- Tablet**
Les produits portant cette icône sont conçus pour porter et protéger une tablette ou un lecteur de livres électroniques.
- Sticky Note™**
Nombre de pages
- Notebooks**
Nombre de pages
- Informations sur l'emballage**

Abréviations

- SP = Sérigraphie
LE = Gravure laser
4CP = Procédé de quadrichromie
HS = Estampage
DB = Embossage
PD = Tampographie
DT = Transfert digital
DG = Digital
BP: britePix™
MOQ: = Quantité minimale de commande

Dimensions

Les dimensions publiées de tous les produits correspondent à la taille maximale, quelle que soit la position du dessin.

ES > Guía de símbolos y abreviaturas

Técnicas de impresión

- Impresión Puffy**
Una atractiva personalización gracias a nuestra tinta Puffy, que proporciona un efecto relieve a tu logo.
 - 4-colour process**
Permite la reproducción de imágenes de alta resolución. Ideal para la reproducción de fotografías. Original y atractivo.
 - Tinta metálica**
Realiza tu mensaje imprimiendo con tinta metálica sin ningún coste adicional. Disponible en colores azul, verde y rosa.
 - Digital transfer**
Ideal para reproducir fotografías, logos e imágenes en digital sobre el encendedor BIC® J25.
 - Digital**
Cuatricromía de alta definición. 360° en el cuerpo entero.
 - britePix™**
Impresión a todo color con resultados fotográficos de alta calidad, que asegura una impresión duradera de su logo.
 - Acabado metálico**
El acabado metálico crea efectos metálicos en imágenes o fondos. Tu marca parecerá única.
 - Acabado holográfico**
Convierte tu logo en una imagen tridimensional usando hologramas. ¡Hace que tu mensaje impacte!
- Modos de escritura**
- | | |
|--------------|------------------|
| • Bolígrafo | • Lápiz |
| • Pluma | • Roller |
| • Resaltador | • Gel |
| • Marcador | • Escritura fina |
| • Portaminas | |
- Tinta: colores disponibles**
- | | |
|------------|--------------------|
| • Negro | • Rosa |
| • Azul | • Azul ultramarino |
| • Rojo | • Verde ácido |
| • Verde | • Rosa chicle |
| • Amarillo | • Púrpura oscuro |
- BIC® Easy-Glide system option**
35% más fluido y más intenso que nuestro bolígrafo actual.

Otros símbolos

- Mix&Match**
Cientos de componentes de instrumentos de escritura para una completa personalización
- PMS Service**
Elija para los atributos, el colour PMS que mejor se adapte a su logo
- 48 hour**
Servicio 48 h disponible

- Mobius loop**
El producto contiene material reciclado.
- Renewable Resource**
Producto elaborado de material ecológico fabricado con materiales de coníferas naturales renovables (polímeros celulósicos).
- AZ antimicrobial**
El aditivo Antimicrobial es una composición química que reduce el crecimiento de bacterias, algas, hongos y moho en el bolígrafo.
- País de origen**
- Nuevos 2015 / Nuevos colores 2015 / Nuevos acabados / Nuevo color de tinta**
- EN 13869**
Regulaciones Europeas para Encendedores con seguridad para niños .
- ISO 22702**
This standard certifies the quality of all utility lighters.
- ISO 9994**
Normas internacionales de seguridad para encendedores.
- Cabin friendly**
Este icono identifica los productos que no superan las medidas máximas de equipaje de mano de la mayoría de las compañías aéreas.
- Laptop**
Los productos con este icono alto han sido diseñados para contener y proteger un ordenador portátil.
- Tablet**
Los productos con este icono están diseñados para contener y proteger un tablet o libro electrónico.
- Sticky Note™**
Número de hojas.
- Notebooks**
Número de hojas.
- Información de envasado**

Abreviaturas

- SP = Serigrafía
LE = Impresión a láser
4CP = Proceso de cuatricromía
HS = Hot stamping
DB = Grabado en relieve
PD = Tampografía
DT = Transferencia digital
DG = Digital
BP: britePix™
MOQ: = Cantidad mínima de pedido

Dimensiones

Las dimensiones publicadas en cada producto corresponden a su tamaño máximo, independientemente de la posición que muestre el dibujo.

DE > Erklärungen zu Symbolen und Abkürzungen

Spezielle Möglichkeiten

- Puffy printing**
Eine überzeugende Personalisierung mit unserer "Puff y"-Tinte, die Ihrem Logo einen Relief-Effekt verleiht.
- 4-colour process**
Aufdruck von Bildern mit hoher Auflösung. Ideal für Fotodrucke. Origineller Blickfang.
- Metallische-Tinte**
Verleihen Sie Ihrer Botschaft ohne Aufpreis eine besondere Wertigkeit mit Metall-Drucktinten. Verfügbar in Blau-, Grün- und Rosatönen.
- Digital transfer**
Ideal für Photos, Logos und Digitalzeichnungen.
- Digital**
Hochauflösender Vierfarb-Prozess. 360° Rundumdruck auf dem ganzen Schaft.
- britePix™**
Ihre Nachricht kann nun in voller Farbe mit grafischer Brillanz gedruckt werden, wobei ein dauerhafter, lebendiger und bleibender Eindruck Ihres Logos sichergestellt wird
- Metallic-Ausführung**
Gestalten Sie Bilder und Hintergründe mit Metall-Effekten. Macht Ihre Marke einzigartig.
- Holographie-Ausfertigung**
Verwandeln Sie Ihr Logo in ein dreidimensionales Bild durch Hologramme. Verleiht Ihrer Botschaft eine atemberaubende Wirkung

Schreibtechniken

- | | |
|--------------------|----------------|
| • Kugelschreiber | • Bleistift |
| • Füllfederhalter | • Rollerball |
| • Leuchtmarker | • Gelschreiber |
| • Permanent Marker | • Fineliner |
| • Druckbleistift | |
- Ink colours**
- | | |
|-----------|------------------|
| • Schwarz | • Rosa |
| • Blau | • Ultramarinblau |
| • Rot | • Acid-Grün |
| • Grün | • Girly-Rosa |
| • Gelb | • Dunkellila |

- BIC® Easy-Glide system option**
35% weicher und präziser als eine herkömmliche Mine.

Andere Symbole

- Mix&Match**
Hunderte von Farben bei den Schreibgeräte-Komponenten auf Lager. Für eine komplette Personalisierung
- PMS Service**
Wählen Sie die PMS-Farbe für Verzierungen, die am besten zu Ihrem Logo passt
- 48 hour**
48 Stunden Service

- Mobius loop**
Das Produkt enthält recyceltes Material.
- Renewable Resource**
Das Produkt ist zu aus umweltfreundlichem Material hergestellt, indem natürliche, erneuerbare Weichholz-Materialien verwendet wurden (Polymer auf Cellulose-Basis).
- AZ antimicrobial**
Das antimikrobielle Additiv ist eine chemische Zusammensetzung, die das Wachstum von Bakterien, Pilzen, Schimmel und Mehltau auf dem Stift reduziert.
- Herkunftsland**
- Neue 2015 / Neue Farben 2015 / Neue Finishes / Neue Schreibfarben**
- EN 13869**
Europäische Kindersicherheitsnorm für Feuerzeuge.
- ISO 22702**
Dieser Standard zertifiziert die Qualität aller Feuerzeuge.
- ISO 9994**
Internationale Sicherheitsstandards für Feuerzeuge.
- Cabin friendly**
Diese Artikel können in den Flugzeugkabinen der meisten grossen Fluggesellschaften mitgeführt werden
- Laptop**
Artikel mit diesem Symbol sind besonders zum Verpacken und Schutz von Laptop Pc's geeignet
- Tablet**
Die Produkte mit diesem Symbol sind dazu entworfen, ein Tablet oder einen E-Reader zu halten und zu schützen.
- Sticky Note™**
Anzahl der Blätter.
- Notebooks**
Anzahl der Blätter.
- Information zu Verpackungen**

Abkürzungen

- SP = Siebdruck
LE = Lasergravur
4CP = 4-Farbdruk
HS = Hotstamping
DB = Prägung
PD = Tampendruck
DT = Digitaldruck
DG = Digital
BP: britePix™
MOQ: = Mindestbestellmenge

Abmessungen

Die Abmessungen, die für jedes Produkt angegeben werden, entsprechen dessen maximaler Größe, in Unabhängigkeit von der Zeichnungsposition.

IT > Guida a simboli e abbreviazioni

Opzioni speciali

- Puffy printing**
Una personalizzazione evidenziata con il nostro inchiostro "Puffy" per dare un effetto a rilievo al tuo logo.
- 4-colour process**
Consente la riproduzione di immagini ad alta risoluzione. Ideale per la riproduzione di fotografie. Originale e attraente.
- Inchiostro metallizzato**
Valorizza il tuo messaggio con inchiostri di stampa metallizzati senza costi aggiuntivi. Disponibile nei colori blu, verde e rosa.
- Digital transfer**
Ideale per la riproduzione di fotografie, loghi ed immagini digitali sull' accendino.
- Digital**
Alta definizione - stampa in digitale in quadricromia, 360° gradi su tutta la lunghezza del corpo.
- britePix™**
Il messaggio può essere stampato a colori con l'eccellente risoluzione fotografica che assicura un'impressione durevole e vibrante del vostro logo
- Finitura metallica:**
Crea effetti, immagini o sfondi metallici. Il tuo marchio sarà inconfondibile
- Finitura olografica**
Trasforma il tuo logo in un'immagine tridimensionale con gli ologrammi. Rende il tuo messaggio straordinario.

Modalità di scrittura

- | | |
|----------------------|-------------|
| • Penna a sfera | • Matita |
| • Penna Stilografica | • Roller |
| • Evidenziatore | • Gel |
| • Pennarello | • Finestyle |
| • Portamine | |
- Colori della cartuccia refill**
- | | |
|----------|-----------------|
| • Nero | • Rosa |
| • Blu | • Blu oltremare |
| • Rosso | • Verde mela |
| • Verde | • Rosa |
| • Giallo | • Viola scuro |
- BIC® Easy-Glide system option**
Offre il 35% di scrittura più fluida e corpora rispetto agli inchiostri standard.

Altri simboli

- Mix&Match**
Centinaia di colori dei componenti di produzione degli strumenti di scrittura per una personalizzazione completa
- PMS Service**
Scegli il colore PMS per le finiture che meglio si adatta al tuo logo

- 48 hour**
Servizio in 48 ore disponibile
- Mobius loop**
Il prodotto contiene materiale riciclato.
- Renewable Resource**
Prodotto composto da materiale ecologico, realizzato con materiali naturali di conifere rinnovabili (polimeri cellulósicos).
- AZ antimicrobial**
L'additivo antimicrobico è una composizione chimica che riduce la crescita di batteri, alghe, funghi e muffe sulla penna.
- Paese d'origine**
- Nuovi 2015 / Nuovi colori 2015 / Nuove finiture / Nuovi colori di scrittura**
- EN 13869**
Normativa europea per accendini sulla sicurezza dei bambini.
- ISO 22702**
Questa normativa certifica la qualità di tutti i nostri accendini.
- ISO 9994**
Norme di sicurezza internazionali per gli accendini.
- Cabin friendly**
Questa icona identifica quei prodotti che possono essere portati a bordo dell'aereo perché conformi ai limiti di bagaglio delle principali compagnie aeree.
- Laptop**
I prodotti con questa icona sono adatti a contenere e proteggere un tablet o e-reader.
- Tablet**
I prodotti con questa icona sono adatti a contenere e proteggere un computer portatile.
- Sticky Note™**
Numero di fogli.
- Notebooks**
Numero di fogli.
- Informazioni sul packaging.**

Abbreviazioni

- SP = Serigrafia
LE = Incisione laser
4CP = Stampa in quadricromia
HS = Stampa a caldo
DB = Bassorilievo
PD = Stampa a tampone
DT = Trasferimento digitale
DG = Digitale
BP: britePix™
MOQ: = Quantità minima d'ordine

Dimensioni

Le dimensioni pubblicate relative a ciascun prodotto corrispondono alla sua dimensione massima indipendentemente dalla posizione del disegno.

A guide to symbols and abbreviations

Printing Techniques



Puffy Printing

A highlighted personalisation with our "Puffy" ink, giving a relief effect to your logo.



4-Colour Process

Allows reproduction of high-resolution images. Ideal for reproducing photos. Original and eye-catching.



Metallic Ink

Upgrade your message with metallic imprint inks at no charge. Available in blue, green and pink colours.



Digital Transfer

Ideal for reproducing photographs, logos and digital images on BIC® J25.



Digital

High-definition 4-colour process. 360° degrees and full length of the barrel/body.



britePix™

Full colour with photographic excellence, producing a durable imprint that ensures lasting impressions of your logo.



Metallic Finish

Create metallic effects, images and backgrounds. Make your brand look unique!



Holographic Finish

Convert your logo into a three-dimensional image using holograms. Makes your message breathtaking

Writing Modes



M Medium
F Fine

Ballpen



FP Fountain Pen



HL Highlighter



MK Marker



MP

Mechanical Pencil

Ø 0,7mm



PC Pencil



R Roller Ball



G Gel



FS Finestyle

Ink Colours



BIC® Easy-Glide system option

Offers 35% smoother and bolder write-out than our standard ink.

Other Symbols



Mix&Match

Hundreds of colours of components in stock of writing instruments for full personalisation



PMS Service

Choose the PMS colour for trims that best matches your logo



48-Hour

48-Hour Printing Service



Möbius Loop

Product contains recycled material.



Renewable Resource

Product made with eco-friendly material manufactured using natural, renewable softwood materials (cellulosic polymers).



AZ Antimicrobial

The Antimicrobial additive is a chemical composition that reduces the growth of bacteria, algae, fungus, mould and mildew on the pen.



Country of Origin



New / New 2015 Colours / New Finishes / New Ink Colour



EN 13869

European Child Resistant Regulation for lighters.



ISO 22702

This standard certifies the quality of all utility lighters.



ISO 9994

International Safety Standards for lighters.



Cabin Friendly

This icon identifies products that meet carry-on luggage limits of most major airlines.



Laptop

Products with this icon are designed to hold and protect a laptop.



Tablet

Products with this icon are designed to hold and protect a tablet or e-reader.



Sticky Note™

Number of sheets.



Notebooks

Number of sheets.



Packaging Information

250
± 5,3 Kg

Abbreviations

SP = Screen printing

LE = Laser engraving

4CP = 4-colour process

HS = Hot stamping

DB = Debossing

PD = Pad printing

DT = Digital transfer

DG = Digital

BP = britePix™

MOQ = Minimum order quantity

Dimensions

Dimensions published of each product correspond to its maximum size, regardless of the drawing position.



Writing instruments

Ballpens

BIC® 2 in 1 Stylus	.87
BIC® 4 Colours	.82
BIC® 4 Colours Fashion	.86
BIC® 4 Colours Shine	.85
BIC® 4 Colours Mini	.84
BIC® Atlantis®	.77
BIC® Attriant®	.112
BIC® Celebrate	.80
BIC® Citation	.79
BIC® Clic Stic	.56
BIC® Clic Stic Antimicrobial	.60
BIC® Clic Stic Digital	.59
BIC® Clic Stic Mini Digital	.59
BIC® Clic Stic Softfeel®	.58
NEW COLOURS BIC® Ecolutions® Clic	.78
BIC® Ecolutions® Clic Gold	.78
BIC® Media Clic	.50
BIC® Media Clic Grip	.53
NEW FINISHES BIC® Media Clic Grip Digital	.54
BIC® Media Clic Premium	.52
BIC® Media Max	.72
BIC® Media Max Digital	.74
BIC® Media Max Premium	.75
BIC® Media Max Premium Digital	.76
BIC® Pivo® Metal	.107
BIC® Protrusion Grip	.111
BIC® Rondo Style Classic	.110
BIC® Rondo Style Rubberised	.110
BIC® Round Stic®	.46
NEW BIC® Round Stic® Digital	.48
BIC® Round Stic® Antimicrobial	.60
BIC® Slim Metal	.106
BIC® Style	.44
BIC® Style Clear	.45
BIC® Super Clip	.62
BIC® Super Clip britePix™	.64
NEW BIC® Super Clip Digital	.65
NEW BIC® Super Clip britePix™ Digital	.65
BIC® Tri-Tone Twist	.113
BIC® Wide Body™	.66
NEW FINISHES BIC® Wide Body™ Chrome	.69
NEW FINISHES BIC® Wide Body™ Digital	.71
NEW FINISHES BIC® Wide Body™ Digital Chrome	.71

BIC® Wide Body™ Grip	.68
BIC® Wide Body™ Metal	.108
BIC® Wide Body™ Metal Grip	.109
BIC® Wide Body™ Mini Digital	.70
NEW FINISHES BIC® Wide Body™ Mini Digital Chrome	.70

Colouring Pens

NEW BIC® Kids PLASTIDECOR®	.98
NEW BIC® Kids PLASTIDECOR® britePix™	.98

Graphite & Mechanical Pencils

BIC® Clic Matic	.105
BIC® Ecolutions® Evolution Classic	.100
BIC® Ecolutions® Evolution Colour Connection	.102
BIC® Ecolutions® Evolution Digital	.101
BIC® Ecolutions® Evolution Digital Colour Connection	.102
BIC® Matic®	.103
BIC® Matic® Grip	.104
BIC® Matic® Quartz	.103
BIC® Media Clic	.50
BIC® Media Clic Grip	.53
BIC® Media Clic Grip Digital	.54
BIC® Rondo Style Classic	.110
BIC® Rondo Style Rubberised	.110
BIC® Wide Body™ Metal	.108

Highlighters & Markers

BIC® Brite Liner® Grip	.96
BIC® Brite Liner® Grip XL	.97
NEW BIC® Ecolutions® Permanent Marker	.95
BIC® Great Erase White Board Marker	.93
BIC® Mark-it Permanent Marker	.94

Rollers

BIC® Grip Roller	.89
NEW INK COLOUR BIC® Intensity® Clic Gel	.91
BIC® Triumph 537R	.88
BIC® Velocity® Gel	.90
BIC® XS Finestyle	.92
NEW BIC® XS Finestyle britePix™	.92





Style

- EN > Worldwide recognised BIC® cap shape.
Excellent value for money.
- FR > Capuchon BIC® reconnu mondialement.
Excellent rapport qualité-prix.
- ES > Tapón BIC® reconocido mundialmente.
Excelente relación calidad precio.
- DE > BIC®-Kappe mit weltweitem Wiedererkennungswert.
Ausgezeichnetes Preis-Leistungs-Verhältnis.
- IT > Cappuccio BIC® conosciuto in tutto il mondo.
Eccellente rapporto qualità/prezzo.



1610
Ballpen
Bille
Bolígrafo
Kugelschreiber
Penna a sfera

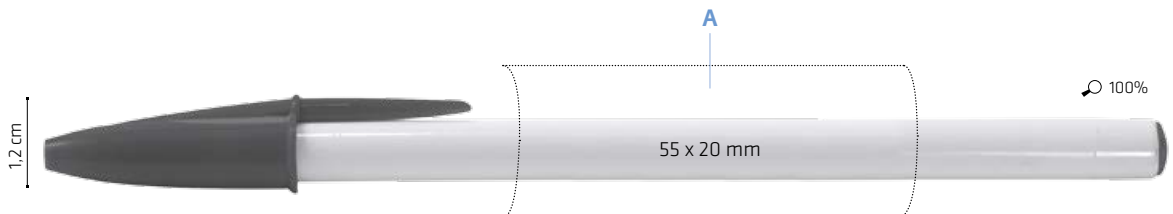

A> SP: max. 2 colours

14,9 cm

Barrel and Cap
OPAQUE



MOQ: 500 u.   
± 3.5 Kg



Style Clear

- EN > **Colourful range** with blue and black ink options.
- FR > **Large gamme de coloris** avec option encre bleue et noire.
- ES > **Amplia gama de colores** con opción de tinta azul o negra.
- DE > **Breite Farbpalette**, optional blaue oder schwarze Tinte.
- IT > **Vasta gamma di colori** con opzioni di inchiostro blu o nero.



1611
Ballpen
Bille
Bolígrafo
Kugelschreiber
Penna a sfera

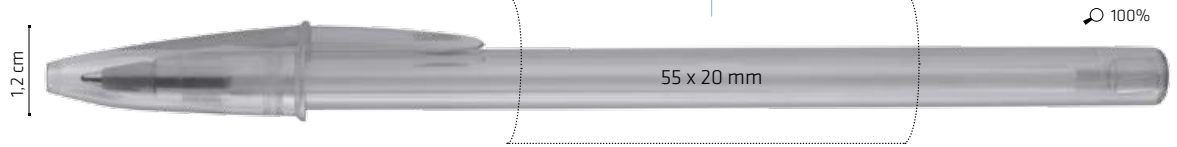

A> SP: max. 2 colours

14,9 cm

Barrel and Cap
CLEAR



MOQ: 500 u.   M  500
± 3.5 Kg



Round Stic®

BY THE EXPERT
*of Writing
Instruments* 

EN > The iconic BIC® Round Stic® offers **timeless style** and **high quality**. Its classic design is **easy to identify** and symbolizes long-term reliability.





Round Stic®

FR > L'icône BIC® Round Stic® offre un **style indémodable** et une **très grande qualité**. Son design classique est **facile à identifier** et symbolise une fiabilité à long terme.

ES > El icónico BIC® Round Stic® ofrece un **estilo atemporal y de calidad**. Su diseño clásico se **identifica fácilmente** y simboliza la fiabilidad a largo plazo.

DE > Unser kultiger BIC® Round Stic® bietet **zeitloses Design in bester Qualität**. Sein klassisches Design ist **einfach zu erkennen** und spiegelt lang anhaltende Zuverlässigkeit wieder.

IT > L'iconica BIC® Round Stic offre uno stile **intramontabile ed alta qualità**. Il suo design classico la rende **facilmente riconoscibile** ed è prova di una longeva affidabilità.



Scan this page, live the BIC Graphic Augmented Reality experience and share it!

100%

1010
Ballpen
Bille
Bolígrafo
Kugelschreiber
Penna a sfera

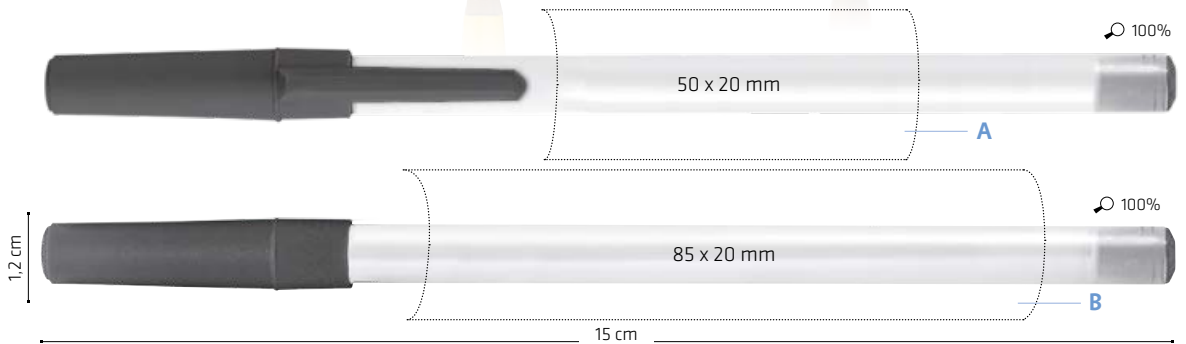

A> SP: max. 3 colours
B> SP: max. 1 colour



Cap, Section and Button				Barrel			
OPAQUE		FROSTED		OPAQUE		FROSTED	
01	02	03	04	01	02	03	04
05	07	10	12	05	07	12	06
18	20	71		18		71	

MOQ: 500 u.

PMS SERVICE
≥10.000 u.



M



+ 2.5 Kg



Recycled Content
Option pg 179



MADE IN SPAIN

Red ink available under request



Round Stic® **NEW** Digital



BY THE PIONEER
*in Digital
printing*

EN > **Now** available with **360° photo-quality full-colour imprint!** Thousands of colour combinations and large imprint area at very **competitive prices**. The communication you want at the price you need!





Round Stic® Digital



NEW

FR > Désormais disponible avec **impression photo couleur de haute qualité à 360°** ! Des milliers de combinaisons de couleurs et une grande zone d'impression à un **prix très compétitif**. La communication que vous voulez au prix qui vous convient !

ES > Ahora disponible impresión **360° a todo color con calidad fotográfica**. Miles de combinaciones de colores y un gran área de marcado a un **precio muy competitivo**. ¡La comunicación que quieres al precio que necesitas!

DE > Nun erhältlich mit **360° Vollfarbdruck in Fotoqualität**. Tausende möglicher Farbkombinationen und ein großer Druckbereich zu einem sehr **wettbewerbsfähigen Preis**. Die Kommunikation, die Sie sich wünschen, zum Preis, den Sie brauchen!

IT > Ora disponibile con **stampa a colori di qualità fotografica a 360°**! Migliaia di combinazioni di colore e ampia area di stampa a **prezzi davvero competitivi**. La comunicazione che vuoi al prezzo che ti conviene!



Scan this page, live the BIC Graphic Augmented Reality experience and share it!

100%

100%

1881
Ballpen
Bille
Boligrafo
Kugelschreiber
Penna a sfera

1,2 cm



80 x 25,2 mm

15 cm

A> DG: full colour



Cap, Section and Button OPAQUE				FROSTED			
01	02	03	04	40	63	66	
05	07	10	12	67	68	69	
18	20			71			

Barrel
OPAQUE
01

MOQ: 500 u.

PMS SERVICE
≥10.000 u.



Red ink available under request



Media Clic

BY THE EXPERT
*of Writing
Instruments* 

EN > The promotional writing instrument of excellence, our number one, **the original**. Multiple **printing possibilities** on the barrel and on the clip, and **thousands of colour combinations**. Now up to **4 colour imprint** available on the barrel.





Media Clic

FR > L'instrument d'écriture promotionnel par excellence, notre favori, **l'original**. De nombreuses **possibilités d'impression** sur le corps et le clip, et des **milliers de combinaisons de couleurs**. Nous pouvons désormais **imprimer jusqu'à 4 couleurs** sur le corps.

ES > El instrumento de escritura promocional por excelencia, nuestro número uno, **el original**. Múltiples **posibilidades de impresión** en el cuerpo y en el clip, y **miles de combinaciones de colores**. Ahora es posible imprimir hasta **4 colores** en el cuerpo.

DE > Das Schreibgerät par excellence unter den Werbegeschenken, die Nummer Eins unserer Kunden, **das Original**. Vielfältige **Druckmöglichkeiten** auf Schaft und Clip und **Tausende von Farbkombinationen**. Nun ist es möglich, **bis zu 4 Farben** auf den Schaft zu drucken.

IT > Lo strumento di scrittura promozionale per eccellenza, il nostro numero uno, **l'originale**. Tante possibilità **di stampa** sul fusto e sulla clip e **migliaia di combinazioni di colore**. Ora anche con **stampa in quadricromia** sul fusto.

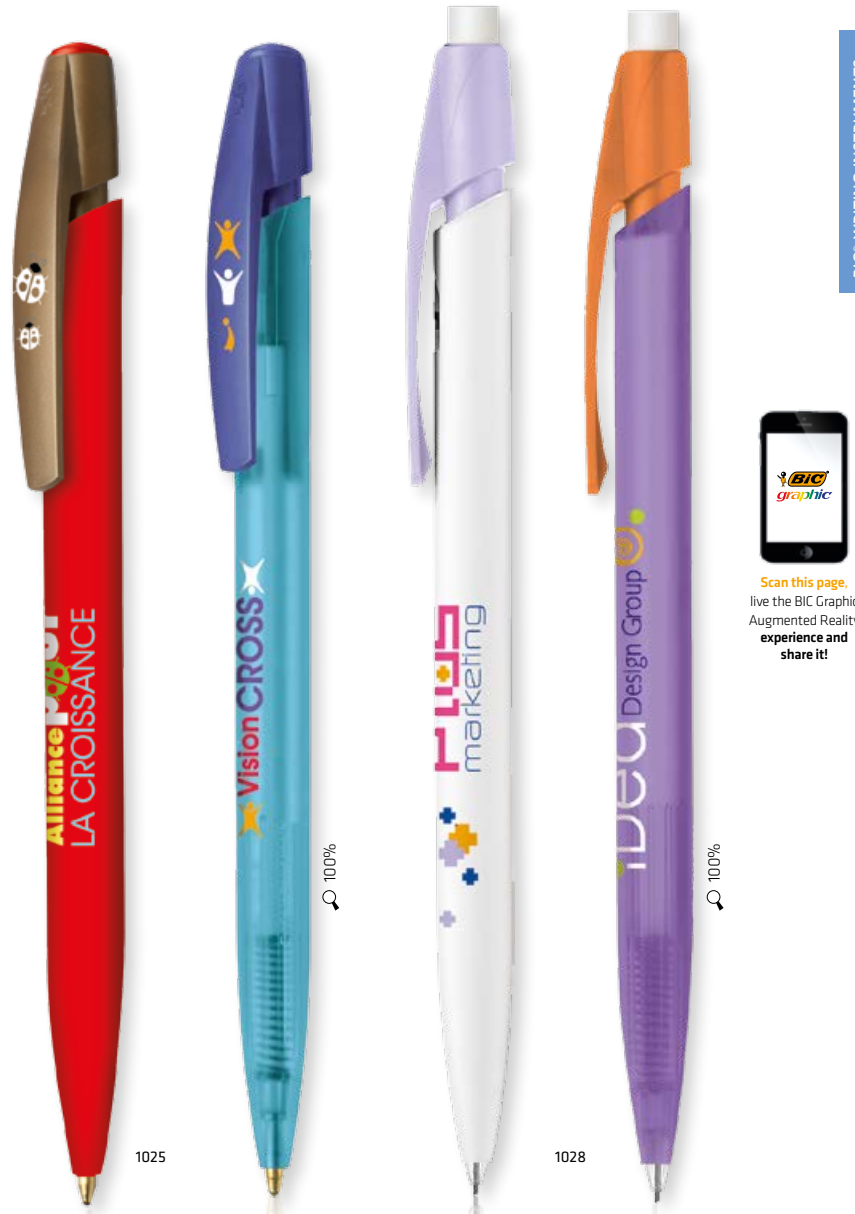

1025
Ballpen
Bille
Bolígrafo
Kugelschreiber
Penna a sfera

1028
Mechanical pencil
Porte-mine
Portaminas
Druckbleistift
Portamine

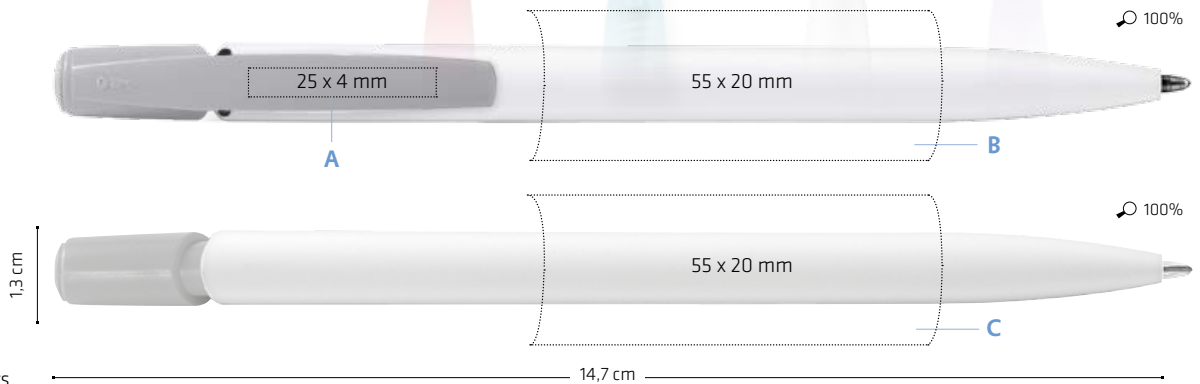

A> SP: max. 2 colours
B/C> SP: max. 4 colours

MIX & MATCH

Clip and Button
OPAQUE: 01, 02, 28, 03, 04, 05, 07, 69
FROSTED: 69

Barrel
OPAQUE: 01, 02, 03, 04, 05, 07, 10, 12, 18, 3C, 2D, 5C, 6C, 3D, 85, 83, 8D

FROSTED: 38, 48, 39, 40, 63, 66, 67, 68, 69, 71, 82

MOQ: 500 u.
PMS SERVICE ≥10.000 u.

48h, PUFFY, M, MP, 500, ±4,1 Kg, BIC e solutions Recycled Content Option pg 180, MADE IN SPAIN

Red ink available under request
BIC® Easy-Glide system option



Media Clic Premium

EN > Luxurious and affordable. Exclusive and versatile. The **premium version of the iconic BIC® Media Clic** aims to be the ideal gift pen as well as to fit any budget. **Weighted barrel with metallic colour finish.**

FR > À la fois luxueux et abordable. Exclusif et polyvalent. **La version premium du BIC® Media Clic** iconique est un cadeau idéal accessible pour tous les budgets. **Corps lesté, finition métallique et détails chromés.**

ES > Lujoso a la vez que asequible. Exclusivo a la vez que versátil. **La versión premium del icónico BIC® Media Clic** logra ser el bolígrafo de regalo ideal así como encajar en cualquier presupuesto. **Cuerpo diseñado con peso interno, acabado metálico y atributos de color cromados.**

DE > Luxus, den man sich leisten kann. Exklusiv und vielseitig. **Die Premiumversion des Kultkugelschreibers BIC® Media Clic** ist nicht nur das ideale Geschenk, sondern passt auch in jedes Budget. **Schaft mit Gewicht im Innern, Metallicfinish und verchromten Verzierungen.**

IT > Lussuosa ma accessibile. Esclusiva ma versatile. **La versione premium dell'iconica BIC® Media Clic** riesce ad essere la penna regalo ideale per qualsiasi budget. **appesantita internamente e con finiture metallizzate a colori.**



Scan this page, live the BIC Graphic Augmented Reality experience and share it!

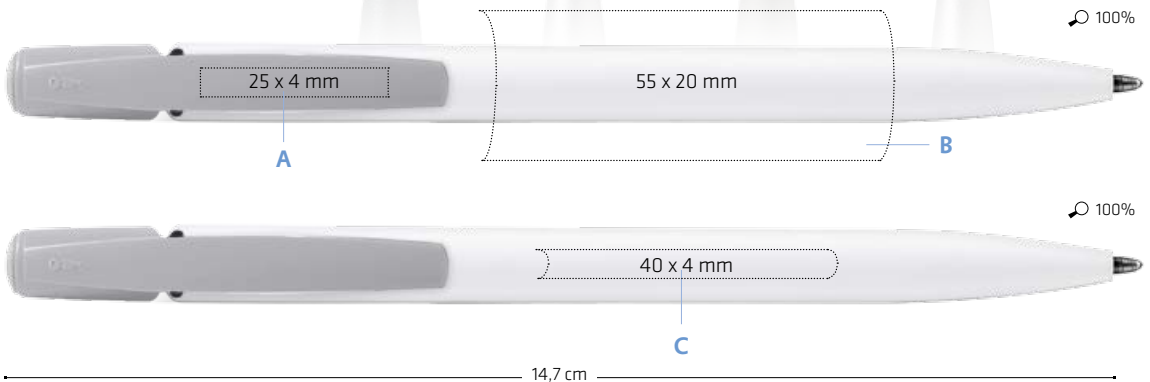

1D25
Ballpen
Bille
Bolígrafo
Kugelschreiber
Penna a sfera

A> SP: max. 1 colour
B> SP: max. 2 colours
C> LE

Clip	Button	Barrel
4A 5A	35	4A 5A 7A 8A

MOQ: 250 u.

Red ink available under request
BIC® Easy-Glide system option



Media Clic Grip

- EN > Reliable plunger action mechanism. **Soft touch gripping section. Now up to 4 colours imprint** available on the barrel.
- FR > Mécanisme fiable et rétractable par appui sur le poussoir. **Grip au toucher doux.** Nous pouvons **désormais imprimer jusqu'à 4 couleurs** sur le corps.
- ES > Fiable mecanismo de accionamiento retráctil en el pulsador. **Sección con grip de tacto suave. Ahora es posible imprimir hasta 4 colores** en el cuerpo.
- DE > Zuverlässiges Druckschreibgerät. **Soft-Touch-Griffzone.** Nun ist es möglich, **bis zu 4 Farben** auf den Schaft zu **drucken**.
- IT > Affidabile meccanismo a scatto. **Impugnatura morbida al tatto. Ora disponibile anche stampa in quadricromia** sul fusto.



Scan this page, live the BIC Graphic Augmented Reality experience and share it!

1020
Ballpen
Bille
Bolígrafo
Kugelschreiber
Penna a sfera

1021
Mechanical pencil
Porte-mine
Portaminas
Druckbleistift
Portamine

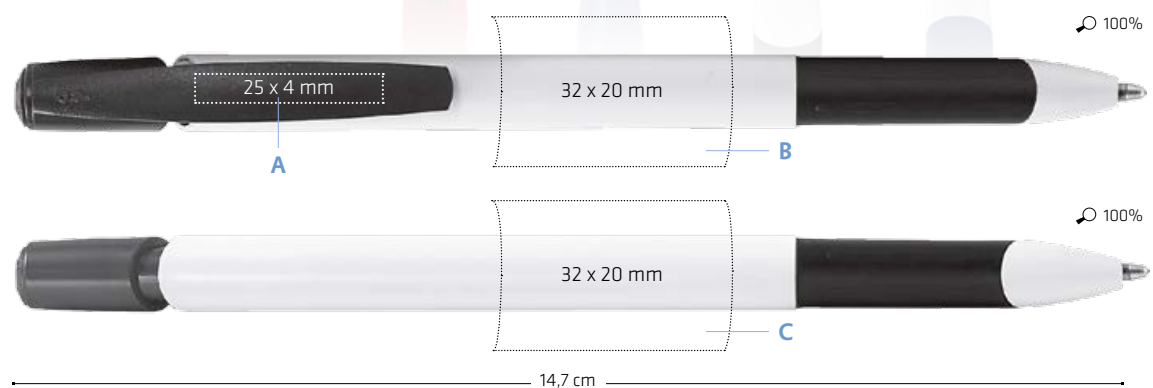

A> SP: max. 2 colours
B / C> SP: max. 4 colours



Clip and Button

OPAQUE	01	02	2B	03	04	05	07
	10	12	13	18	29	2D	5C
	3D	85	83	84			

FROSTED
69

Barrel and Grip

OPAQUE	01/02	01/03	01/05
	01/07	01/12	

Barrel and Grip

FROSTED	01/69	40/69	66/69
	69/69	71/69	82/69

NEW COLOUR

MOQ: 500 u.
PMS SERVICE
≥ 20.000 u.

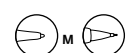

Red ink available under request
BIC® Easy-Glide system option





Media Clic Grip Digital



BY THE PIONEER
*in Digital
printing*

EN > **Now 360° photo-quality full-colour imprint available on all frosted and opaque barrel colours!** Reinventing the digital to maximize your personalisation options.





Media Clic Grip Digital



FR > Désormais disponible avec impression photo couleur de haute qualité à 360° sur tous les corps de couleur translucides ou opaques! Nous réinventons le numérique pour vous offrir plus de possibilités de personnalisation.

ES > ¡Ahora impresión 360° a todo color con calidad fotográfica en todos los cuerpos frosted y opacos! Reinventamos la tecnología digital para ofrecer más opciones de personalización.

DE > Nun 360° Vollfarbdruck in Fotoqualität auf allen gefrosteten oder opaken Schäften! Wir haben die Digitaltechnik neu erfunden, um mehr Personalisierungsoptionen anzubieten.

IT > Stampa a colori di qualità fotografica a 360° ora disponibile su fusti di tutti i colori, frosted e opachi! Reinventiamo la stampa digitale per ottimizzare le tue possibilità di personalizzazione.



NEW FINISHES



NEW FINISHES



NEW FINISHES



Scan this page, live the BIC Graphic Augmented Reality experience and share it!

1886
Ballpen
Bille
Bolígrafo
Kugelschreiber
Penna a sfera

1887
Mechanical pencil
Porte-mine
Portaminas
Druckbleistift
Portamine



A> SP: max. 2 colours
B> DG: full colour



Clip and Button OPAQUE

01	02	28	03	04	05	07
10	12	13	18	29	2D	5C
3D	85	83	84			

FROSTED

Barrel and Grip OPAQUE

01/02	01/03	01/05
01/07	01/12	

Barrel and Grip FROSTED

01/69	40/69	66/69
69/69	71/69	82/69

NEW COLOUR

MOQ: 500 u.

PMS SERVICE
≥ 20.000 u.



Red ink available under request BIC® Easy-Glide system option



Clic Stic



EN > Modern, flexible, reliable.
That's how BIC® Clic Stic is!
A large **variety of finishes**
such as Digital, Softfeel®,
Mini and Antimicrobial, and
**more than 4.000 colour
combinations!**



Clic Stic

FR > Moderne, flexible et fiable. Ainsi se définit BIC® Clic Stic ! Une grande **variété de finitions** : numérique, Softfeel®, Mini ou Antimicrobial, **et plus de 4 000 combinaisons de couleurs !**

ES > Moderno, flexible, fiable. Así es BIC® Clic Stic! Amplia **variedad de acabados**, como Digital, Softfeel®, Mini o Antimicrobial y **más de 4.000 combinaciones de colores!**

DE > Modern, flexibel, zuverlässig. Das ist BIC® Clic Stic! Breite **Palette an Ausführungen**, wie Digital, Softfeel®, Mini oder Antimikrobiell und **über 4.000 mögliche Farbkombinationen!**

IT > Moderna, flessibile, affidabile. È il ritratto di BIC® Clic Stic! Un **ampia gamma** come Digitale, Softfeel®, Mini o Antimicrobial e **più di 4.000 combinazioni di colori!**



Scan this page, live the BIC Graphic Augmented Reality experience and share it!

1000
Ballpen
Bille
Bolígrafo
Kugelschreiber
Penna a sfera

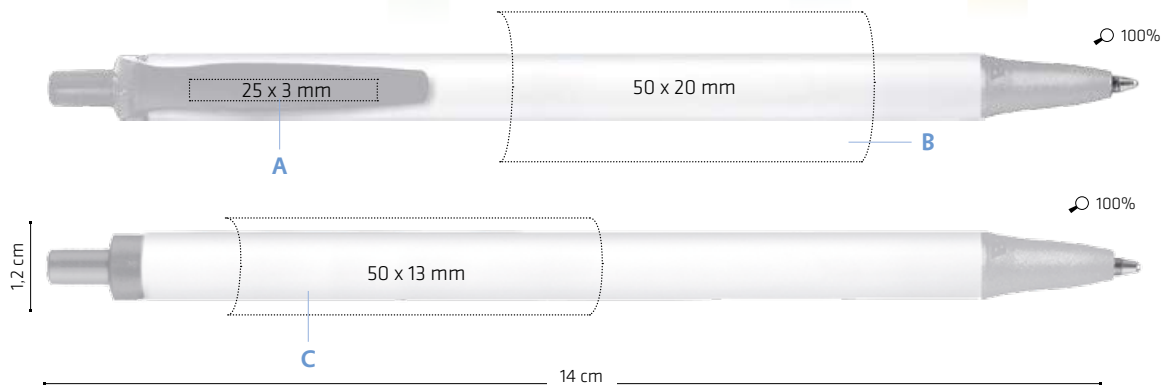

A > SP: max. 1 colour
B > SP: max. 3 colours
C > SP: max. 2 colours



Clip and Section				Barrel					
OPAQUE		FROSTED		OPAQUE		FROSTED			
01	02	03	04	40	63	66			
05	07	10	12	04	05	07	67	68	69
18	20			12	18		71		

MOQ: 500 u.
PMS SERVICE
≥ 10.000 u.



Red ink available under request
BIC® Easy-Glide system option



Clic Stic Softfeel®

- EN > The **Softfeel®** rubberised barrel adds a **pleasant soft touch** to the BIC® Clic Stic.
- FR > Le **corps Softfeel®** confère un **toucher doux et agréable** au BIC® Clic Stic.
- ES > El **cuerpo Softfeel®** añade un **agradable y suave tacto** a BIC® Clic Stic.
- DE > Dank **Softfeel®**-**Schaft** fühlt sich **der BIC® Clic Stic** angenehm weich an.
- IT > Il **corpo Softfeel®** aggiunge un **tocco gradevole e morbido** a BIC® Clic Stic.



Scan this page, live the BIC Graphic Augmented Reality experience and share it!

100%

1005
Ballpen
Bille
Bolígrafo
Kugelschreiber
Penna a sfera

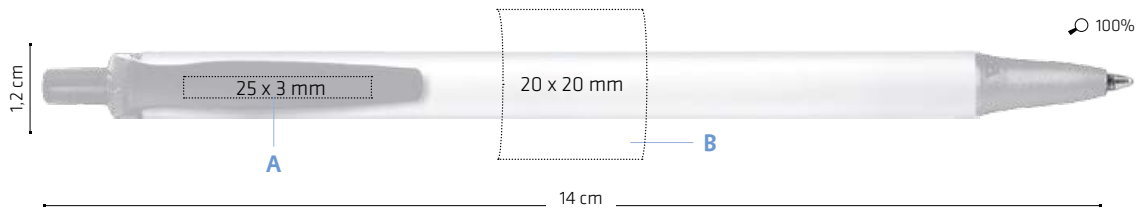

100%

A/B> SP: max. 1 colour



Clip and Section

OPAQUE				FROSTED			
01	02	03	04	40	63	66	
05	07	10	12	67	68	69	
18	20	71					

Barrel

OPAQUE	FROSTED
02	07
05	40

MOQ: 500 u.

PMS SERVICE
≥ 10.000 u.



± 2,9 Kg



Red ink available under request
BIC® Easy-Glide system option



Clic Stic Digital & Mini Digital



1882

- EN > **Full-barrel, full-colour** 360° photo-quality imprint and many colours available to **communicate your message!**
- FR > **Impression photo couleur** de haute qualité à 360° sur tout le corps et de nombreuses couleurs au **choix assorties à votre message!**
- ES > ¡Impresión 360° a **todo color** con calidad fotográfica en todo el cuerpo y muchos colores disponibles **a juego con tu comunicación!**
- DE > **Vollschaff-Vollfarbdruck** in 360° Fotoqualität und in vielen Farben erhältlich, **um Ihre Botschaft treffend zu kommunizieren!**
- IT > **Stampa a colori di qualità fotografica a 360° sull'intero fusto** e tanti colori disponibili da abbinare **al tuo messaggio!**

1892 Mini Digital

- EN > **Full-colour** communication in a **convenient size.**
- FR > Communication en **couleur pour une taille compacte.**
- ES > Comunicación a **todo color** en **tamaño compacto.**
- DE > **Vollfarbkommunikation** in **Kompaktgröße.**
- IT > Comunicazione **a colori** in **formato compatto.**



Scan this page, live the BIC Graphic Augmented Reality experience and share it!

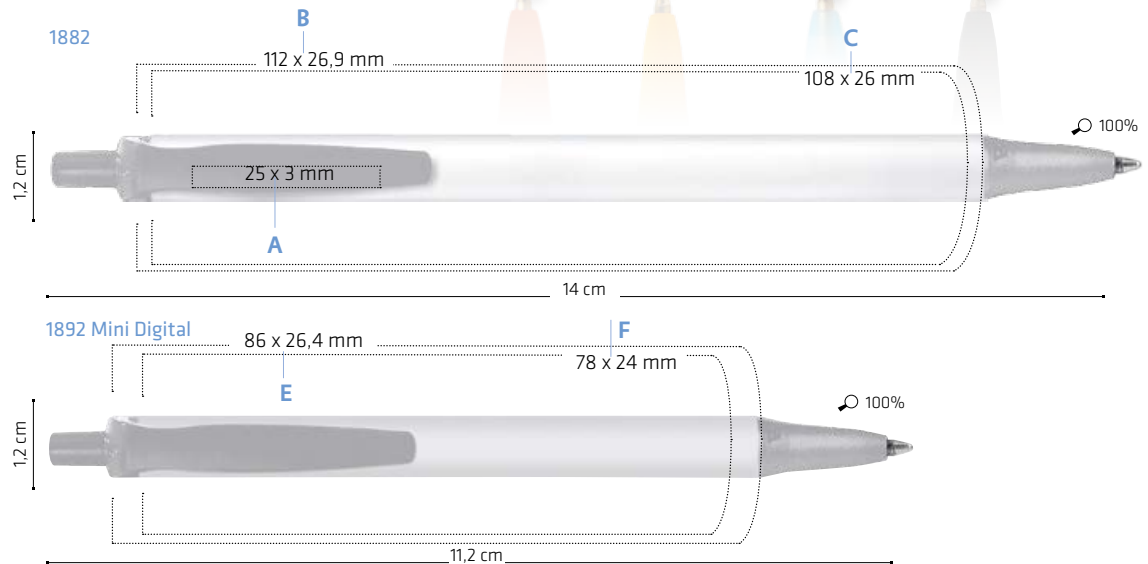

1882 / 1892 Mini Digital
Ballpen
Bille
Bolígrafo
Kugelschreiber
Penna a sfera

A > SP: max. 1 colour
B / E > DG: full colour (area for images)
C / F > DG: full colour (area for text)



Clip and Section

OPAQUE



FROSTED



Barrel

OPAQUE



MOQ: 500 u.

PMS SERVICE
≥ 10.000 u.



1882

500

+ 2,9 Kg

1892

500

+ 2,6 Kg

BIC eSolutions
Recycled Content
Option pg 184*

* 1882



* Red ink only for 1882
Red ink available under request
BIC® Easy-Glide system option only for 1882



anti *microbial*



EN > Reduces the growth of bacteria, algae, fungus, mould and mildew on the pen.



Round Stic® & Clic Stic



- EN > Add the AZ antimicrobial logo to your artwork at no additional charge. Please be sure to specify "Print the logo AZ antimicrobial" on your order or ask for optional packaging: cello wrap + AZ leaflet.
- FR > Freine la prolifération de bactéries, d'algues, de champignons et de moisissure sur le stylo.
Ajouter le logo antimicrobien AZ à votre illustration, sans coût additionnel. Pour cela, il vous suffit de spécifier "Imprimer le logo AZ antimicrobiens" sur votre commande. Vous pouvez également demander pour l'emballage optionnel : cello wrap + AZ notice.
- ES > Reduce el crecimiento de bacterias, algas, hongos y mohedad en el bolígrafo.
Añade el logo antimicrobiano AZ a su arte final sin coste adicional. Por favor, asegúrate de especificar "Impresión del logo AZ antimicrobiano" en tu pedido o solicita el envasado opcional: cello wrap + prospecto AZ.
- DE > Unterdrückt das Wachstum von Bakterien und anderen Mikroorganismen auf dem Kugelschreiber.
Ergänzen Sie Ihr Design mit dem AZ antimikrobiellen Logo ohne Zusatzkosten. Vergewissern Sie sich, dass Sie auf Ihrem Auftrag "Drucken Sie das antimikrobielle AZ-Logo" vermerkt haben. Oder fragen Sie nach alternativer Verpackung: Klarsichtige Verpackung und AZ Leaflet.
- IT > Previene la crescita di batteri, alghe, funghi e muffe sulla penna. Aggiungi il logo antimicrobico AZ alla grafica senza costi supplementari. Assicurati di specificare sul tuo ordine "Stampa del logo antimicrobico AZ". Oppure richiedi la confezione opzionale: cellofan + prospecto AZ.

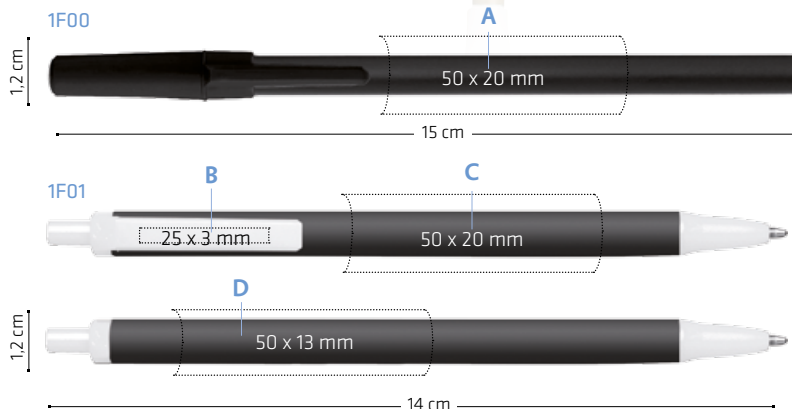

1F00 / 1F01
Ballpen
Bille
Bolígrafo
Kugelschreiber
Penna a sfera

A / C > SP: max. 3 colours
B > SP: max. 1 colour
D > SP: max. 2 colours

Barrel / Trims / Ink

OPAQUE

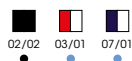

Optional packaging:



MOQ: 500 u.



1F01



1F00



1F00



± 2,5 Kg

1F01



± 2,9 Kg

* Not available with Optional packaging



Super Clip

BY THE PIONEER
*in Digital
printing*

EN > Stylish and modern clip design with **britePix™ full-colour imprint** available. Smooth and unbreakable twist mechanism. **Now also available with 360° photo-quality full-colour imprint on the barrel!**





Super Clip

FR > Clip de design moderne et chic disponible avec impression **britePix™** toutes couleurs. Mécanisme de rotation souple et incassable. **Désormais disponible avec impression photo couleur de haute qualité à 360° sur le corps !**

ES > Clip estiloso y moderno disponible con **impresión a todo color en britePix™**. Suave e irrompible mecanismo pivotante. **¡Ahora también disponible con impresión 360° a todo color con calidad fotográfica en el cuerpo!**

DE > Stylishes und modernes Clip-Design mit **britePix™-Vollfarbdruck** erhältlich. Leichtgängiger, unzerbrechlicher Drehmechanismus. **Nun auch in 360°-Vollfarbdruck in Fotoqualität auf dem Schaft erhältlich!**

IT > Design elegante e moderno della clip con possibilità **di stampa a colori britePix™**. Meccanismo a rotazione scorrevole e indistruttibile. **Ora disponibile anche con stampa a colori di qualità fotografica a 360° sul fusto!**



Scan this page, live the BIC Graphic Augmented Reality experience and share it!



Scan this page, enjoy the BIC GRAPHIC Augmented Reality experience and share it!

1039
Ballpen
Bille
Bolígrafo
Kugelschreiber
Penna a sfera



A> SP: max. 1 colour
B> SP: max. 2 colours



Clip and Barrel
OPAQUE



CLEAR



MOQ: 250 u.



+ 2,6 Kg



PMS SERVICE
≥ 10.000 u.



Super Clip

britePix™

EN > Exclusive **britePix™ full-colour** concept **on the clip**: bring your message to life!
The largest imprint area on the clip!

FR > Concept exclusif **britePix™ toutes couleurs sur le clip** : rendez votre message vivant !
La plus grande zone d'impression sur le clip !

ES > Concepto exclusivo **britePix™ a todo color en el clip**: ¡tu mensaje cobra vida!
¡El área de marcaje más grande en el clip!

DE > Exklusives **britePix™ -Vollfarbkonzert auf dem Clip**: Erwecken Sie Ihre Botschaft zum Leben!
Größter Druckbereich auf dem Clip.

IT > Esclusivo **concetto di stampa a colori britePix™ sulla clip**: da' vita al tuo messaggio!
La più ampia area di stampa sulla clip!



Scan this page, live the BIC Graphic Augmented Reality experience and share it!

100%

1894 **britePix™**
Ballpen
Bille
Bolígrafo
Kugelschreiber
Penna a sfera

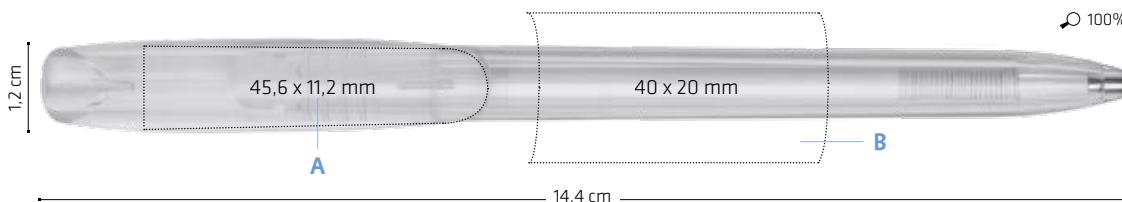

A> BP: full colour
B> SP: max. 2 colours



Clip and Barrel

OPAQUE

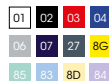

CLEAR



MOQ: 250 u.



250
± 2,6 Kg



PMS SERVICE
≥ 10.000 u.



BY THE PIONEER
in Digital printing

Super Clip Digital & Super Clip britePix™ Digital

NEW



- EN > Now also available with 360° photo-quality full-colour imprint on the barrel and also with britePix™ full colour on the clip. Top brand exposure thanks to the large communication surface!
- FR > Désormais disponible avec impression photo couleur de haute qualité à 360° sur le corps, et impression britePix™ toutes couleurs sur le clip. Pour une meilleure visibilité de votre marque grâce à sa grande zone d'impression !
- ES > Ahora también disponible con impresión 360° a todo color con calidad fotográfica en el cuerpo y también impresión en el clip en britePix™. ¡Máxima exposición de marca gracias a su gran superficie de comunicación!
- DE > Nun auch in 360° -Vollfarbdruck in Fotoqualität auf dem Schaft erhältlich und ebenso britePix™ -Vollfarbdruck auf dem Clip. Top-Markendarstellung dank der großen Kommunikationsoberfläche!
- IT > Ora disponibile anche con stampa a colori di qualità fotografica a 360° sul fusto, oltre che con stampa a colori britePix™ sulla clip. La migliore visibilità al tuo marchio grazie all'ampia area di stampa!



Scan this page, live the BIC Graphic Augmented Reality experience and share it!

100%

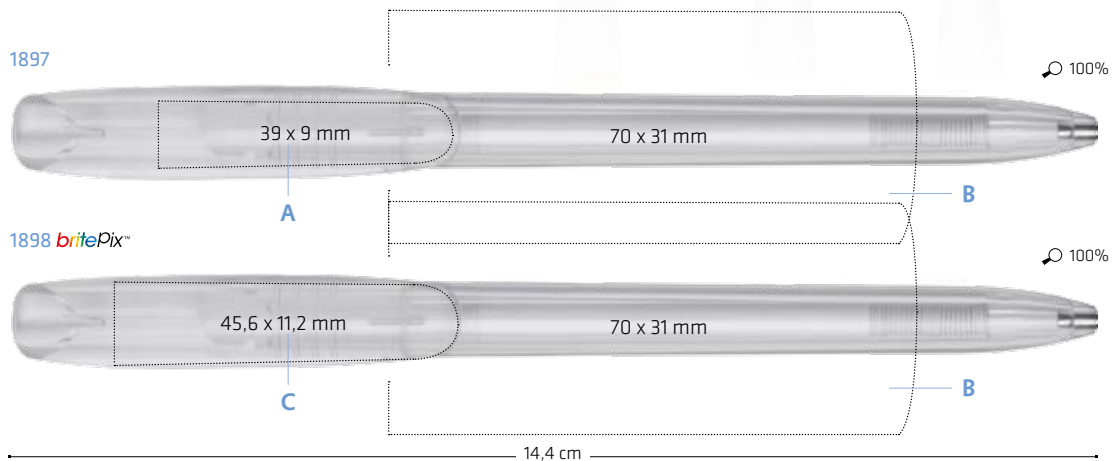

1897 / 1898 britePix™
Ballpen
Bille
Bolígrafo
Kugelschreiber
Penna a sfera

A> SP: max. 1 colour
B> DG: full colour
C> BP: full colour

Clip and Barrel
OPAQUE

01

MOQ: 250 u. M 250 ± 2,6 Kg MADE IN SPAIN

PMS SERVICE ≥ 10.000 u.



Wide Body™

BY THE PIONEER
*in Digital
printing*

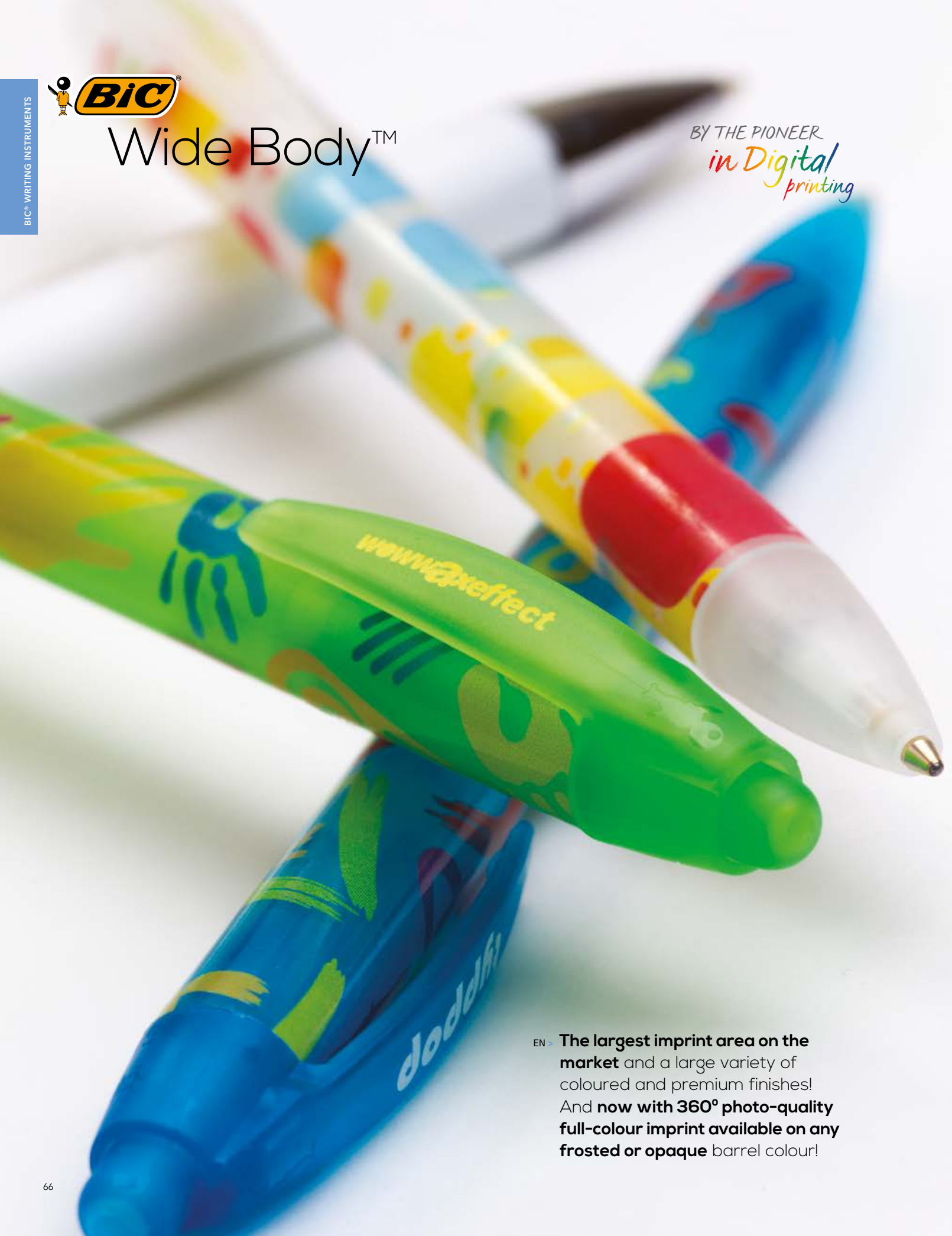

EN - **The largest imprint area on the market** and a large variety of coloured and premium finishes! And **now with 360° photo-quality full-colour imprint available on any frosted or opaque barrel colour!**



Wide Body™

FR > La plus grande zone d'impression sur le marché et une grande variété de couleurs et de finitions haut de gamme ! Et désormais disponible avec impression photo couleur de haute qualité à 360° sur n'importe quel corps de couleur translucide ou opaque !

ES > ¡El mayor área de marcaje del mercado y una gran variedad de colores y acabados premium! Y ahora disponible impresión 360° a todo color con calidad fotográfica en cualquier color de cuerpo opaco o frosted.

DE > Die größte Druckfläche auf dem Markt und eine Vielzahl an Farb- und Premium-Ausführungen! Und nun auch mit 360° -Vollfarbdruck in Fotoqualität auf allen gefrosteten oder opaken Schafffarben erhältlich!

IT > La più ampia area di stampa sul mercato e una vasta gamma di finiture colorate! Ora con stampa a colori di qualità fotografica a 360° disponibile su qualsiasi colore del fusto, frosted o opaco!



Scan this page, live the BIC Graphic Augmented Reality experience and share it!

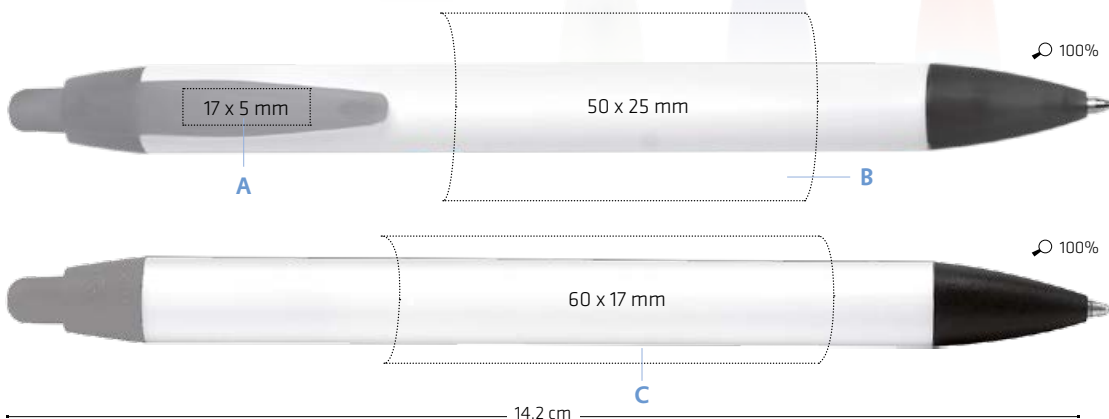

1080
Ballpen
Bille
Bolígrafo
Kugelschreiber
Penna a sfera

A> SP: max. 1 colour
B / C> SP: max. 2 colours



1080
Barrel, Clip and Section

OPAQUE				FROSTED			
01	02	03	40	63	66	67	
07	18		68	69	71		

MOQ: 250 u.

PMS SERVICE
≥10.000 u.*

* ≥25.000 u. for custom made Section



Red ink available under request
BIC® Easy-Glide system option



Wide Body™ Grip

- EN > **Soft rubber grip** and large imprint area.
- FR > **Zone de préhension en caoutchouc souple** et large zone d'impression.
- ES > **Grip suave de caucho** y amplia área de impresión.
- DE > **Weiche Griffzone** und großzügige Druckfläche.
- IT > **Impugnatura in gomma morbida** con ampia area di stampa.



Scan this page, live the BIC Graphic Augmented Reality experience and share it!

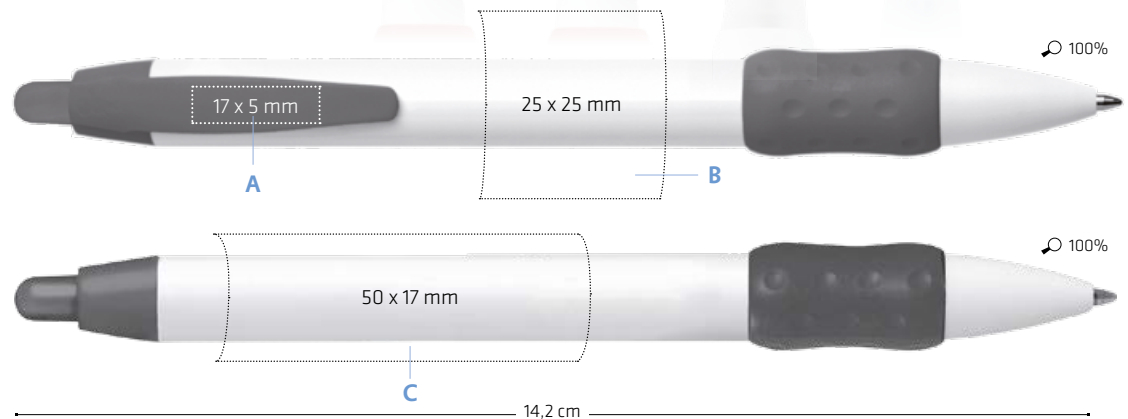

1082 / 1084 Ice
Ballpen
Bille
Bolígrafo
Kugelschreiber
Penna a sfera

A > SP: max. 1 colour
B / C > SP: max. 2 colours

1082
Barrel and Trims
OPAQUE

01/03	01/07

1084 Ice
Barrel and Trims
FROSTED

51/69	86/69	88/69	89/69	92/69	93/69

MOQ: 250 u. M 250 ± 2.7 Kg



Wide Body™ Chrome

- EN > The **premium version of BIC Wide Body™**, now available with **chrome-coloured cover!**
- FR > **Version haut de gamme du BIC® Wide Body™** avec section de couleur chromée désormais disponible aussi avec **bouton de couleur chromée!**
- ES > ¡Ahora la **versión más premium del BIC® Wide Body™** también disponible con el **botón del pulsador en color cromado!**
- DE > Nun ist die **Premium-Version des BIC® Wide Body™** mit chromfarbiger Fläche auch mit **chromfarbigem Druckknopf erhältlich!**
- IT > Ora la **versione più esclusiva di BIC® Wide Body™**, disponibile anche con **pulsante cromato!**



Scan this page, live the BIC Graphic Augmented Reality experience and share it!

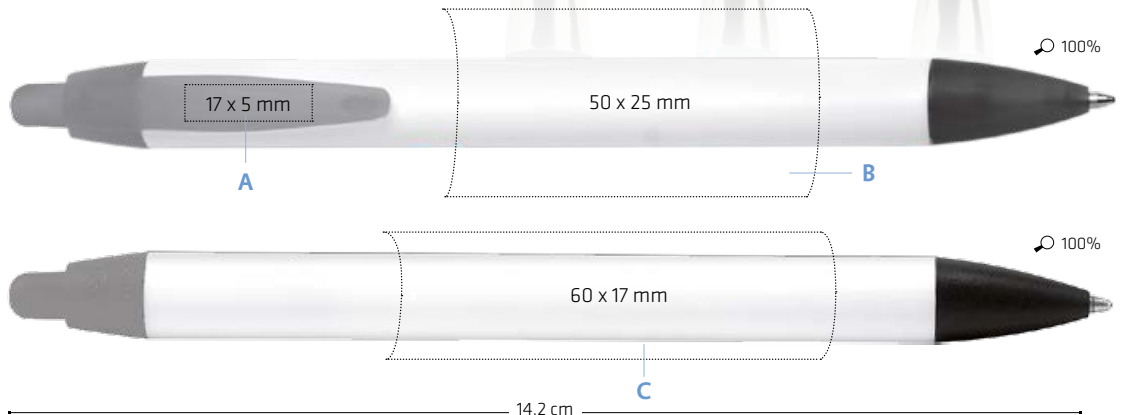

1079 Chrome
Ballpen
Bille
Bolígrafo
Kugelschreiber
Penna a sfera

A> SP: max. 1 colour
B / C> SP: max. 2 colours



1079 Chrome
Barrel and Clip

OPAQUE			FROSTED				Section
01	02	03	40	63	66	67	35
07	18		68	69	71		

Cover

OPAQUE			FROSTED			
01	02	03	40	63	66	67
07	18	35	68	69	71	



MOQ: 250 u.



± 2,6 Kg



PMS SERVICE
≥ 10.000 u.



Red ink available under request
BIC® Easy-Glide system option



Wide Body™ Mini Digital & Mini Digital Chrome



NEW COLOUR

- EN > **Full-colour** communication on a **convenient size**. Combine trim colours or turn it premium by adding the chrome-coloured section and **the new chrome cover!**
- FR > Pour une communication **haute en couleurs** dans un **format pratique**. Combinez les couleurs des attributs ou donnez au stylo une touche haut de gamme en ajoutant le **nouveau bouton** et la section de couleur **chromée!**
- ES > **Comunicación a todo color** en un **tamaño compacto**. Combina los colores de los atributos o ¡conviértelos en premium añadiendo **el botón del pulsador** y/o la sección en **color cromado!**
- DE > **Vollfarb-Kommunikation** in **praktischer Größe**. Kombinieren Sie die Farben der Zierleiste oder machen Sie ein Premium-Gerät daraus, indem Sie die chromfarbige Fläche mit dem **neuen chromfarbigen Druckknopf** kombinieren!
- IT > Il messaggio **più colorato** in un **pratico formato**. Combina i colori delle finiture o rendila esclusiva aggiungendo la sezione in colore cromato e il **nuovo pulsante cromato!**



Scan this page, live the BIC Graphic Augmented Reality experience and share it!

100%

1893 / 1896 Chrome
Ballpen
Bille
Bolígrafo
Kugelschreiber
Penna a sfera

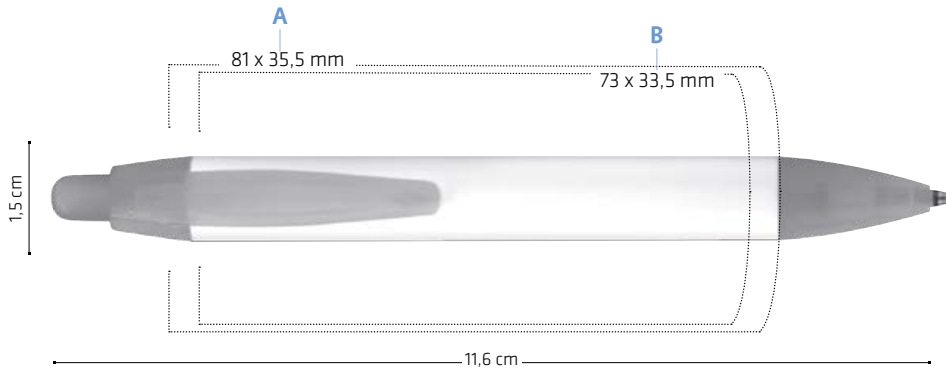

A > DG: full colour (area for images)
B > DG: full colour (area for text)



1893 Barrel OPAQUE

Clip, Cover and Section	
OPAQUE	FROSTED
01	40 63 66 67
07 18	68 69 71

1896 Chrome

Cover	
OPAQUE	FROSTED
01 02 03	40 63 66 67
07 18 35	68 69 71

Section

35

MOQ: 500 u.

PMS SERVICE ≥10.000 u.*

* ≥ 25.000 u. for custom made Section



250 ± 19 Kg



NEW COLOUR



BY THE PIONEER
in Digital printing

Wide Body™ Digital & Wide Body™ Digital Chrome



- EN > Now 360° photo-quality full-colour imprint available on all frosted and opaque barrel colours!** Reinventing the digital to maximize your personalisation options. Combine the coloured trim or turn it premium by adding the chrome-coloured section and the **new chrome-coloured cover!**
- FR > Désormais disponible avec impression photo couleur de haute qualité à 360° sur tous les corps de couleur translucides et opaques !** Nous réinventons le numérique pour vous offrir de plus grandes possibilités de personnalisation. Combinez les couleurs des attributs ou donnez au stylo une touche haut de gamme en ajoutant le **nouveau bouton** et la section **de couleur chromée !**
- ES > Ahora, disponible impresión a todo color con calidad fotográfica 360° en todos los colores del cuerpo, opacos o frosted.** Renovamos el digital para ofrecerte más opciones de personalización. Combina los atributos de colores vivos ¡o conviértelos en premium añadiendo el **botón del pulsador** y la sección **en color cromado!**
- DE > Nun auch in 360° -Vollfarbdruck in Fotoqualität auf allen gefrostenen oder opaken Schafffarben erhältlich!** Neuerfindung des Digitaldrucks zur Maximierung Ihrer Personalisierungsoptionen. Kombinieren Sie die Farben der Zierleiste oder machen Sie ein Premium-Gerät daraus, indem Sie die chromfarbige Fläche mit dem **neuen chromfarbigen Druckknopf** kombinieren!
- IT > Stampa a colori di qualità fotografica a 360° ora disponibile su fusti di tutti i colori, frosted e opachi!** Reinventiamo la stampa digitale per ottimizzare le tue possibilità di personalizzazione. Combina una finitura colorata o rendila esclusiva aggiungendo la sezione in colore cromata e il **nuovo pulsante cromato!**



NEW COLOUR

NEW FINISHES



Scan this page, live the BIC Graphic Augmented Reality experience and share it!

100%

100%

1878 / 1895 Chrome

- Ballpen
- Bille
- Bolígrafo
- Kugelschreiber
- Penna a sfera

- A> SP: max. 1 colour
- B> DG: full colour (area for images)
- C> DG: full colour (area for text)

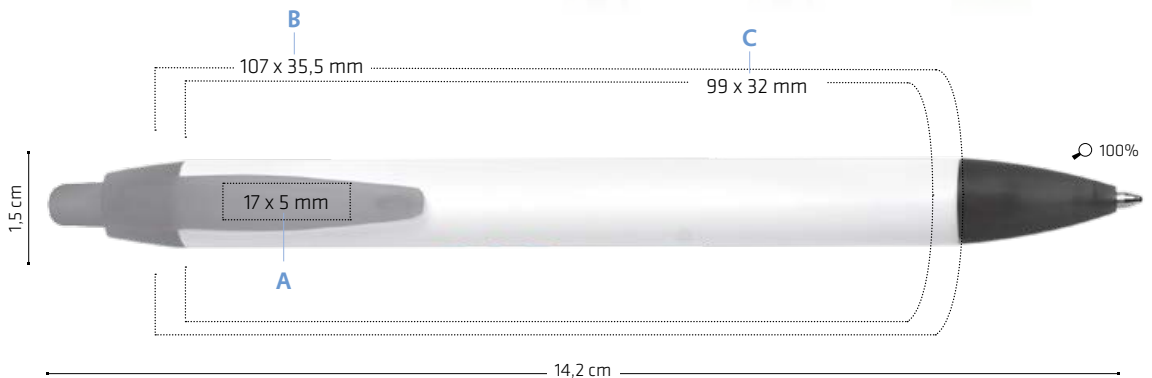

1878

Barrel, Clip, Cover and Section

01	02	03	40	63	66	67
07	18	68	69	71		

1895 Chrome

Cover

01	02	03	40	63	66	67
07	18	35	68	69	71	

NEW COLOUR

Section

35

MOQ: 500 u.

PMS SERVICE
≥ 10.000 u.*

* ≥ 25.000 u. for custom made Section



Red ink available under request BIC® Easy-Glide system option



± 2,6 Kg



Option pg 187*

* 1878





Media Max



EN > **Mix&Match colour combination** offered in up to **5 different parts**: barrel, grip, section, clip and button!
Now up to **4 colour imprints** available on the barrel.



Media Max

FR > Avec Mix&Match, associez les couleurs sur **5 parties différentes** : corps, grip, section, clip et bouton ! Nous pouvons désormais **imprimer jusqu'à 4 couleurs** sur le corps.

ES > ¡Combina con Mix&Match los colores en hasta **5 partes diferentes**: cuerpo, grip, sección, clip y botón! Ahora es posible **imprimir hasta 4 colores** en el cuerpo.

DE > **Kombinieren Sie mit Mix&Match** die Farben von bis zu **fünf verschiedenen Teilen**: Schaft, Griffzone, Teilstück, Clip und Druckknopf! Nun ist es möglich, bis zu **vier Farben** auf den Schaft zu **drucken**.

IT > **Abbina con Mix&Match** fino a **5 diverse parti colorate**: corpo, grip, sezione, clip e pulsante! Ora disponibile anche **stampa in quadricromia** sul fusto.

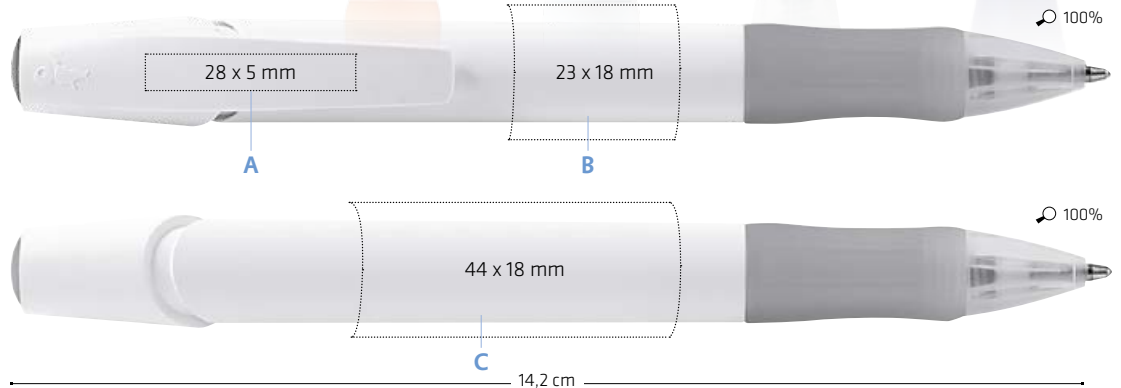

1030
Ballpen
Bille
Bolígrafo
Kugelschreiber
Penna a sfera

A > SP: max. 2 colours
B / C > SP: max. 4 colours



Barrel OPAQUE			FROSTED		
01	02	03	39	40	69
07	10	12	66	68	71
18					

Clip, Grip, Button and Section						
OPAQUE			FROSTED			
01	02	03	38	48	39	40
04	05	07	63	66	67	68
10	12	18	69	71	82	

MOQ: 500 u.

PMS SERVICE
≥ 10.000 u.



Red ink available under request
BIC® Easy-Glide system option



Media Max Digital



- EN > Maximise your communication by choosing the colour of up to **4 colour parts** and printing your logo in **360° photo-quality full-colour imprint on the barrel**.
- FR > Maximisez votre communication en choisissant jusqu'à **4 parties de couleur** différente et en imprimant votre logo à **360° toutes couleurs qualité-photo sur le corps**.
- ES > Maximiza tu comunicación escogiendo el **color** de hasta **4 componentes** e imprime tu logo en **360° a todo color con calidad fotográfica en el cuerpo**.
- DE > Maximieren Sie Ihre Kommunikation durch Wahl der Farbe bei bis zu **4 farbigen Komponenten** und durch den Vollfarbdruck Ihres Logos in **360°-Fotoqualität auf dem Schaft**.
- IT > Ottimizza la comunicazione scegliendo fino a **4 parti di colori** differenti e stampando il tuo logo a colori con **qualità fotografica a 360° sul fusto**.



1874
Ballpen
Bille
Bolígrafo
Kugelschreiber
Penna a sfera

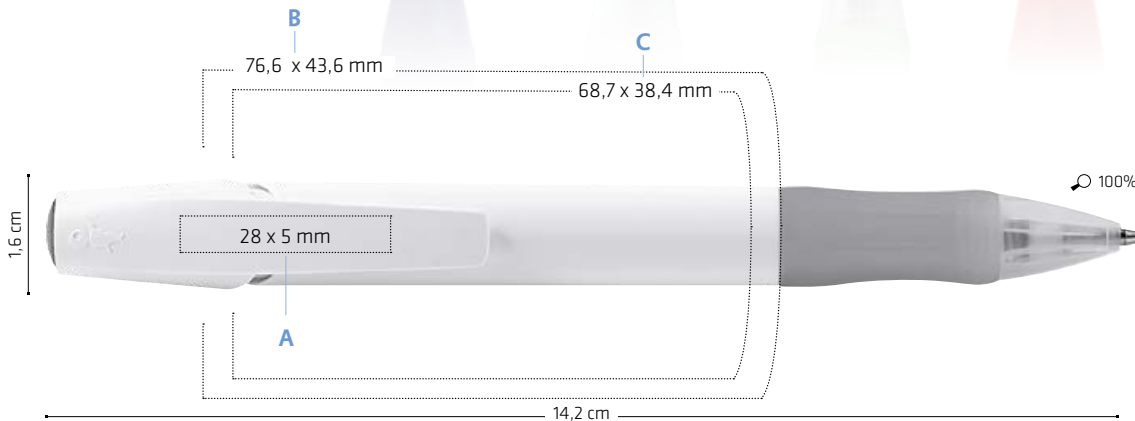

- A> SP: max. 2 colours
- B> DG: full colour (area for images)
- C> DG: full colour (area for text)



Clip, Grip, Button and Section		
OPAQUE	FROSTED	
01	02	03
04	05	07
10	12	18
38	48	39
63	66	67
69	71	82

Barrel OPAQUE
01

MOQ: 500 u.

PMS SERVICE
≥ 10.000 u.



500
± 6 Kg

BIC eSolutions
Recycled Content
Option pg 189



Red ink available under request
BIC® Easy-Glide system option



Media Max Premium

EN > **Elegant metallic colour finish** and metal components to upgrade your message! **The metal section and button** add weight to the pen to increase perceived value and provide **smoother writing**.

FR > **Élégante finition métallisée** avec composants métalliques pour moderniser votre message ! **Le bouton et la section métallisés** donnent plus de poids au stylo pour augmenter la valeur perçue et apporter plus de **souplesse à l'écriture**.

ES > ¡**Elegante acabado de color metálico** y componentes metálicos para modernizar tu mensaje! **La sección y el botón metálicos** añaden peso al bolígrafo para incrementar el valor percibido y proporcionar una **escritura más fluida**.

DE > **Elegante Metallic-Farbausführung und Metallkomponenten**, um Ihre Botschaft edler zu gestalten! Die **Metallfläche** und der **Metallknopf** verleihen Ihrem Kugelschreiber mehr Gewicht, steigern die empfundene Wertigkeit und ermöglichen ein weicheres, **geschmeidigeres Schreiberlebnis**.

IT > **Elegante finitura metallica** e componenti metallici per rendere ancor più efficace il tuo messaggio! **La sezione e il pulsante in metallo** aggiungono peso alla penna, incrementandone il valore percepito e garantendo una **scrittura più uniforme**.

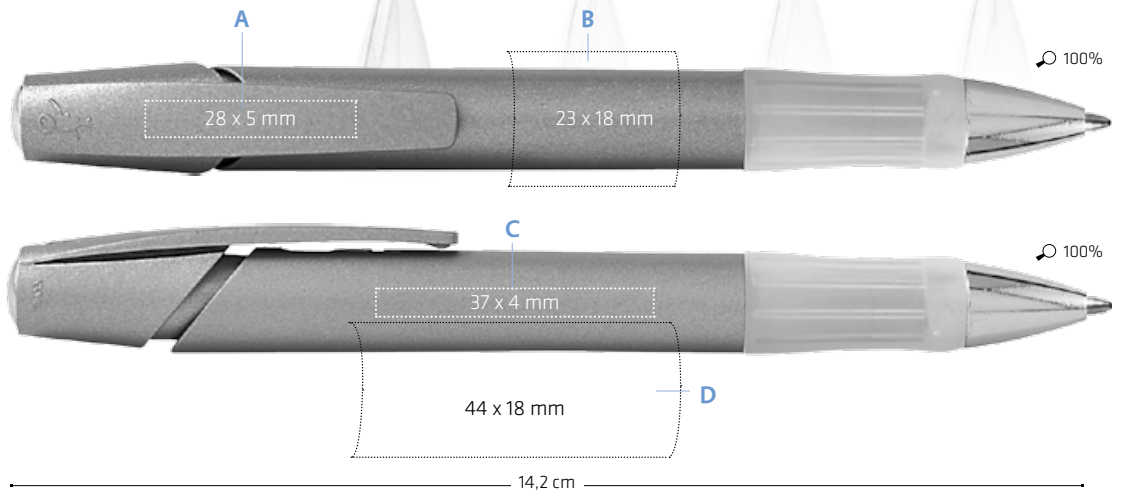

1D30
Ballpen
Bille
Bolígrafo
Kugelschreiber
Penna a sfera

1,6 cm

A> SP: max. 2 colours
B/D> SP: max. 2 colours
C> LE



Button and Section

35

Grip

02 69

Barrel and Clip

4A 7A

MOQ: 250 u.



250

± 5.3 Kg



Red ink available under request
BIC® Easy-Glide system option



Media Max Premium Digital



- EN > **Full-colour** imprint combined with premium **metallic colour finish** and metal trim.
- FR > Impression **toutes couleurs** combinées avec une **finition métallisée** haut de gamme et attributs chromés.
- ES > Impresión **a todo color** combinada con un **acabado premium de color metálico** y atributos cromados.
- DE > **Vollfarbdruck**, kombiniert mit einer Premium-Ausführung in **Metallic-Farben** und chromfarbiger Zierleiste.
- IT > **Stampa a colori** unita a una raffinata **finitura in colore metallizzato** e rifiniture in metallo.

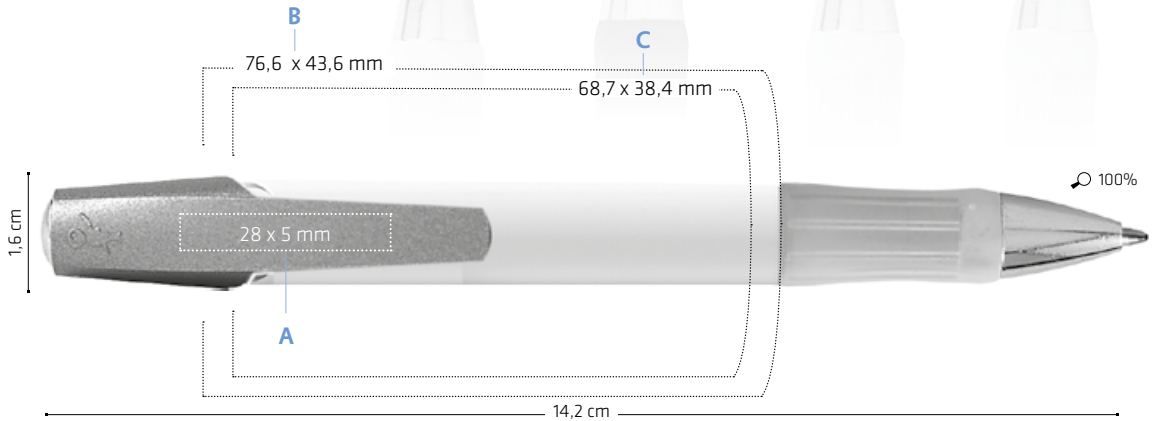

1883
Ballpen
Bille
Bolígrafo
Kugelschreiber
Penna a sfera

A> SP: max. 2 colours
B> DG: full colour
(area for images)
C> DG: full colour
(area for text)



Button and Section

35

Grip

02 69

Clip

4A 7A

Barrel
OPAQUE

01

MOQ: 500 u.



250
± 5,3 Kg



Red Ink available under request
BIC® Easy-Glide system option



Atlantis®

- EN > **Ergonomic design with soft rubber grip.** A smooth writing experience thanks to the **BIC® Easy Glide system®.**
- FR > **Design ergonomique avec grip en caoutchouc souple.** L'expérience d'une écriture toute en souplesse grâce au **système® BIC® Easy Glide.**
- ES > **Diseño ergonómico con suave grip de goma.** Experiencia de escritura fluida gracias al **BIC® Easy Glide system®.**
- DE > **Ergonomisches Design mit weicher Gummigriffzone.** Geschmeidiges, weiches Schreiberlebnis dank des **BIC® Easy Glide Systems®.**
- IT > **Design ergonomico con impugnatura in morbida gomma.** Un'esperienza di scrittura uniforme grazie al **sistema® BIC® Easy Glide.**

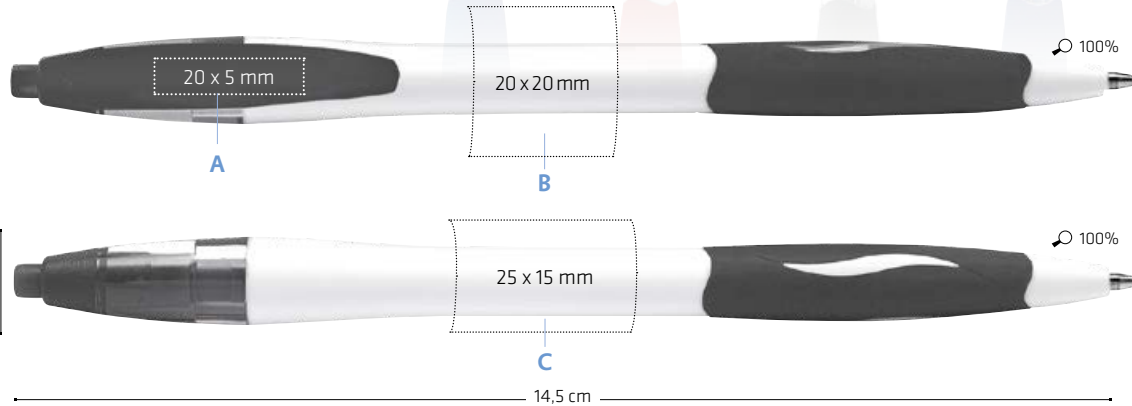

1053 / 1060 Clear

Ballpen
Bille
Bolígrafo
Kugelschreiber
Penna a sfera

A> SP: max. 1 colour
B/C> SP: max. 2 colours

1053

Barrel / Trims / Ink
OPAQUE



1060 Clear

Barrel / Trims / Ink
CLEAR / OPAQUE



MOQ: 250 u.



± 2,3 Kg





BY THE EXPERT
of Writing Instruments

Clic & Clic Gold



- EN > Made with 26% cellulosic polymers, an **eco-friendly material** manufactured using natural, renewable softwood materials. BIC® Clic **is flexible and durable** as well as pleasant to touch, and is offered in a wide variety of colours and finishes.
- FR > Fabriqué avec 26 % de polymères de cellulose, **matériau écologique** obtenu à partir du bois, BIC® Clic est **flexible et durable**, agréable au toucher et il se décline dans une vaste gamme de coloris et de finitions.
- ES > Fabricado con un 26% de polímeros de celulosa, un **material ecológico** realizado a partir de la madera. BIC® Clic es **flexible y duradero** así como agradable al tacto, y se ofrece en una amplia gama de colores y acabados.
- DE > Zu 26% aus Zellulosepolymeren gefertigt, ein aus Holz hergestelltes **ökologisches Material**. BIC® Clic ist **flexibel, langlebig**, ist angenehm anzufassen und wird in einer breiten Palette an Farben und Finishes angeboten.
- IT > Prodotto con un 26% di polimeri di cellulosa, un **materiale ecologico** realizzato partendo dal legno. BIC® Clic è **flessibile e di lunga durata**, ma anche piacevole al tatto, e disponibile in una vasta gamma di colori e finiture.



100%



Wood is collected from softwood and sustainably managed forests. (pg 178)



Bark is used as fuel to convert the wood chips into a renewable plastic.



*The final result is pre-consumer recycled plastic pellets to make BIC® Ecolutions® pens.

1093 /
1092 Clear
1091 Gold /
1090 Gold Clear /
Ballpen
Bille
Bolígrafo
Kugelschreiber
Penna a sfera



100%

A> SP: max. 3 colours

1093
Barrel / Trims
OPAQUE



1092 Clear
Barrel / Trims / Ink
CLEAR

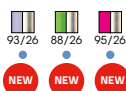

1091 Gold
Barrel / Trims / Ink
OPAQUE

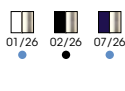

1090 Gold Clear
Barrel / Trims / Ink
CLEAR



1093 /
1092 Clear



1091 Gold /
1090 Clear

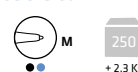

MOQ: 250 u.

*Except for 1D



Citation

- EN > **Elegant classic pen** with slim profile. Polished **nickel-plated trim**.
- FR > **Élégant stylo classique** au profil mince. **Attributs plaqués en nickel**.
- ES > **Elegante bolígrafo** de perfil esbelto. **Acabados bañados en níquel pulido**.
- DE > **Eleganter, klassischer Kugelschreiber** mit schlankem Profil. Die **Zierleiste ist mit poliertem Nickel** beschichtet.
- IT > **Elegante penna classica** dal profilo sottile. **Rifiniture nichelate lucide**.



BIC® WRITING INSTRUMENTS

1620
Ballpen
Bille
Bolígrafo
Kugelschreiber
Penna a sfera

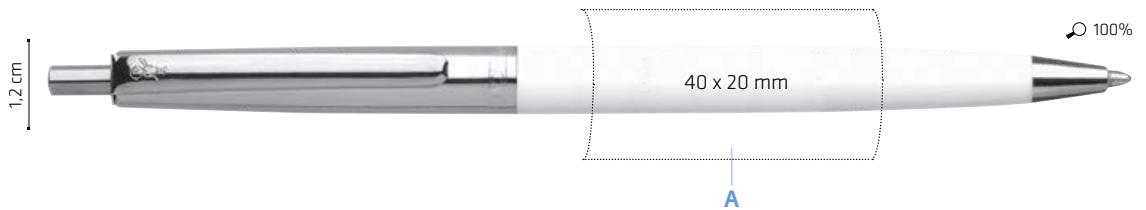

A> SP: max. 2 colours

Barrel
OPAQUE CLEAR
01 02 07 86

MOQ: 250 u. M 250
±1.3 Kg



Celebrate



EN > Inspired by the **worldwide recognised BIC® cap**, the BIC® Celebrate embodies the **timeless style** reminiscent of the legendary BIC® Cristal®.



Celebrate

- FR > Inspiré du capuchon BIC® de renommée mondiale, le BIC® Celebrate incarne le **style intemporel** du légendaire BIC® Cristal®.
- ES > Inspirado en el diseño del tapón BIC® reconocido mundialmente, el BIC® Celebrate encarna el **estilo atemporal** del mítico BIC® Cristal®.
- DE > Inspiriert durch die weltweit bekannte BIC®-Verschlusskappe, verkörpert der BIC® Celebrate den **zeitlosen Stil** des legendären BIC® Cristal®.
- IT > Ispirata dal design del cappuccio BIC® riconosciuto a livello mondiale, BIC® Celebrate incarna lo **stile senza tempo** della leggendaria BIC® Cristal®.



1603

1602

100%

1602 Gold /
1603 Silver
Ballpen
Bille
Bolígrafo
Kugelschreiber
Penna a sfera

1,5 cm



A

100%

A> SP: max. 1 colour

14,5 cm

1602 Gold
Barrel and Cap
OPAQUE

26

1603 Silver
Barrel
OPAQUE

47

MOQ: 250 u.



500

± 3,6 Kg



4 Colours

BY THE EXPERT
*of Writing
Instruments*

EN > Simple, inventive, reliable.
Four different ink colours in one!
Break-away lanyard also available.
An icon that's always in fashion!



4 Colours

- FR > Simple, ingénieux et fiable. **Quatre couleurs d'encre différentes dans un seul stylo !** Également disponible avec tour de cou détachable. **Une icône de la marque qui reste toujours à la mode !**
- ES > Simple, ingenioso, fiable. **¡Cuatro diferentes colores de tinta en un sólo bolígrafo!** Disponible también con lanyard con cierre de seguridad. **¡Un icono que siempre está de moda!**
- DE > Einfach, zuverlässig, einfallsreich. **Vier verschiedene Tintenfarben in einem Kugelschreiber!** Abnehmbares Schlüsselband (Lanyard) ebenfalls erhältlich. **Eine Schreibikone, die immer in Mode bleibt.**
- IT > Semplice, fantasiosa, affidabile. **Quattro diversi colori di inchiostro insieme!** Disponibile anche il lanyard rimovibile. **Un'icona sempre alla moda!**



Scan this page, live the BIC Graphic Augmented Reality experience and share it!

1100 / 1101 Lanyard
Ballpen
Bille
Bolígrafo
Kugelschreiber
Penna a sfera

1,6 cm

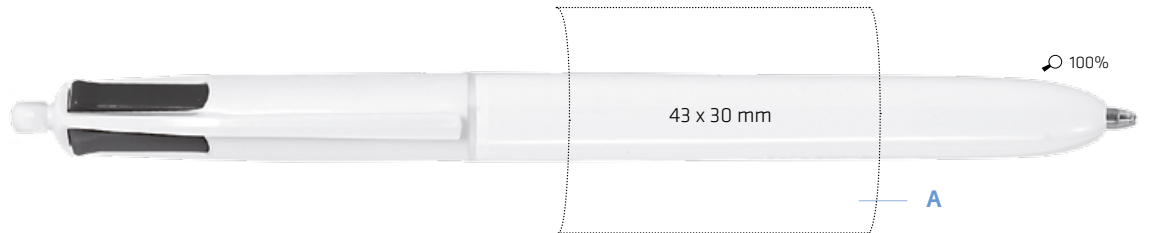

Break-Away Lanyard!

A> SP: max. 4 colours

14,4 cm

1100 / 1101 Lanyard
Cap and Barrel
OPAQUE
01/01 02/02 01/07

MOQ: 250 u. **1100** **1101**
250 300
± 3,2 Kg ± 6 Kg
MADE IN FRANCE

* Only for 1100



4 Colours Mini

- EN > Four different ink colours in one!
Even more functional in a **reduced size**.
Break-away lanyard also available.
- FR > Quatre couleurs d'écriture dans un stylo !
Plus fonctionnel maintenant grâce à sa **taille réduite**.
Désormais plus fonctionnel grâce à sa taille réduit.
- ES > ¡4 colores diferentes de tinta en un producto!
Todavía más práctico con un **tamaño reducido**
Lanyard con cierre de seguridad también disponible.
- DE > Vier verschiedene Tintenfarben in einem Schreibgerät. Noch funktioneller in **reduzierter Größe**.
Break-Away Lanyard ebenfalls verfügbar.
- IT > Quattro colori di inchiostro differenti in un unico prodotto!
Ancora più funzionale grazie alle sue **ridotte dimensioni**.
Disponibile anche lanyard con chiusura di sicurezza.



Scan this page, live the BIC Graphic Augmented Reality experience and share it!

1103
1104 Lanyard
Ballpen
Bille
Bolígrafo
Kugelschreiber
Penna a sfera

1,6 cm

43 x 30 mm

100%

Break-Away Lanyard!

A> SP: max. 4 colours

14,4 cm

1103 / 1104 Lanyard

Cap and Barrel
OPAQUE



MOQ: 250 u.



1103

1104

250

300

± 2,7 Kg

± 5,5 Kg



* Only for 1103



4 Colours Shine

EN > The iconic BIC® 4 Colours presented in **shiny metallic colours**. It features 4 standard colour inks: **blue, black, red and green**.

FR > Le célèbre BIC® 4 couleurs, icône de la marque, présenté dans des **couleurs métallisées brillantes**. Disponible dans 4 couleurs d'encre standard : **bleu, noir, rouge et vert**.

ES > El icónico BIC® 4 Colours presentado en **colores metálicos brillantes**. Cuenta con 4 colores de tinta estándar: **azul, negro, rojo y verde**.

DE > Der ikonische BIC® 4 Colours in **glänzenden Metallic-Farben**. Enthält vier Standard-Farbtinten: **blau, schwarz, rot und grün**.

IT > L'iconica BIC® 4 Colours presentata con **brillanti colori metallici**. Ha 4 inchiostri colorati standard: **blu, nero, rosso e verde**.



NEW



Scan this page, live the BIC Graphic Augmented Reality experience and share it!

100%



Break-Away Lanyard!

- 1106
- 1107 Lanyard
- Ballpen
- Bille
- Bolígrafo
- Kugelschreiber
- Penna a sfera



A> SP: max. 2 colours

1106 / 1107 Lanyard
Cap and Barrel
OPAQUE

MOQ: 250 u.

1106	1107
250	300
± 3.2 Kg	± 6 Kg

MADE IN FRANCE



4 Colours Fashion

EN > **Useful and trendy!** BIC® 4 Colours Fashion is dressed in a charming apple green and white barrel, featuring 4 fashion ink colours: **ultramarine blue, deep purple, acid green and pink.**

FR > **Pratique et à la mode !** BIC® 4 Colours Fashion s'habille d'un corps vert pomme ou blanc et comporte 4 encres modernes : **bleu ultramarin, pourpre sombre, vert acide et rose chewing-gum.**

ES > **¡Práctico y a la moda!** BIC® 4 Colours Fashion viste con cuerpo verde manzana o blanco, y presenta 4 tintas modernas: **azul ultramarino, púrpura oscuro, verde ácido y rosa chicle.**

DE > **Praktisch und trendy!** BIC® 4 Colours Fashion im apfelgrünen oder weißen Schaft mit vier modernen Tinten: **Ultramarin-Blau, Intensiv-Lila, Acid-Grün und Rosa.**

IT > **Pratica e alla moda!** BIC® 4 Colours Fashion ha un corpo verde mela o bianco e offre 4 moderni inchiostri: **blu oltremare, viola scuro, verde acido e rosa chewing gum.**



NEW



Scan this page, live the BIC Graphic Augmented Reality experience and share it!



Break-Away Lanyard!

- 1102
- 1108 Lanyard
- Ballpen
- Bille
- Bolígrafo
- Kugelschreiber
- Penna a sfera

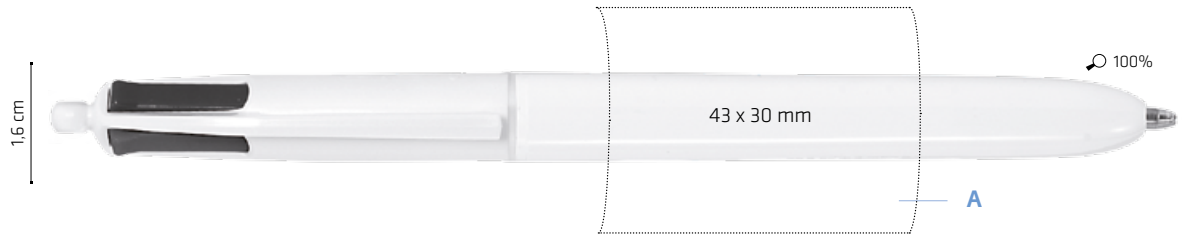

A> SP: max. 4 colours

1102 / 1108 Lanyard
Cap and Barrel
OPAQUE



MOQ: 250 u. **1102** **1108**

 ± 3,2 Kg ± 6 Kg
 MADE IN FRANCE



2 in 1 Stylus

EN > **Lightweight stylus** for capacitive touchscreen devices, including tablets and smartphones! Easily glides across screens providing fingerprint-free precision and control. A smooth writing experience thanks to the **BIC® Easy Glide system®**.

FR > **Stylus léger** pour écrans tactiles, tablettes et smartphone ! Glisse facilement sur les écrans en offrant une précision et un contrôle sans traces de doigt. L'expérience d'une écriture toute en souplesse grâce au **système® BIC® Easy Glide**.

ES > **¡Puntero** para dispositivos de pantalla capacitiva, como tablets y smartphones! Deslizamiento preciso y suave en pantallas táctiles para evitar huellas. Experiencia de escritura fluida gracias al **BIC® Easy Glide system®**.

DE > **Leichtgewichtiger Stylus** für kapazitive Touchscreengeräte, einschließlich Tablets und Smartphones! Gleitet leicht über die Screens, sorgt für Präzision und Kontrolle ohne Fingerabdrücke. Ein weiches, geschmeidiges Schreiberlebnis dank des **BIC® Easy Glide Systems®**.

IT > **Punta** per dispositivi touchscreen, compresi tablet e smartphone! Scivola facilmente su qualsiasi schermo con precisione e controllo senza lasciare impronte. Un'esperienza di scrittura uniforme grazie al **sistema BIC® Easy Glide®**.



1094
Ballpen
Bille
Bolígrafo
Kugelschreiber
Penna a sfera



A> SP: max. 2 colours

14,5 cm

Cap and Barrel
OPAQUE

02

MOQ: 50 u.



250

Standard

± 2.8 Kg



Triumph 537R

- EN > **Smooth-writing roller.**
Barrel wrapped in metallic colour.
- FR > **Roller à écriture fluide.**
Corps recouvert d'un plastique métallisé.
- ES > **Suave escritura roller.**
Cuerpo envuelto con un plastificado metalizado.
- DE > **Rollerball mit angenehmem Schreibkomfort**
Schafthülle in Metallicfarbe.
- IT > **Roller dal tratto fluido.**
Corpo con rivestimento in plastica metallizzata.



1197
Roller Ball
Stylo roller
Roller
Rollerball
Roller



A> SP: max. 1 colour

13,9 cm

Barrel / Ink
OPAQUE



MOQ: 250 u.



400

Ø 0,7mm

± 2.6 Kg



Grip Roller

- EN > **Fast-drying ink** for clean and precise writing.
- FR > **Encre à séchage rapide** pour une écriture propre et précise.
- ES > **Tinta de secado rápido** para una escritura limpia y precisa.
- DE > **Schnell trocknende Tinte** für sauberes und präzises Schreiben.
- IT > **Inchiostro ad asciugatura rapida** per una scrittura pulita e precisa.



Scan this page, live the BIC Graphic Augmented Reality experience and share it!

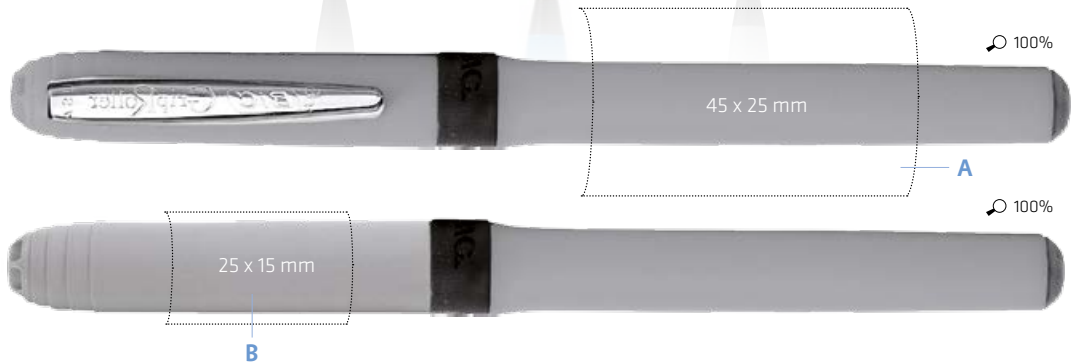

1187 / 1195 Gold
 Roller Ball
 Stylo roller
 Roller
 Rollerball
 Roller

A / B > SP: max. 2 colours

1187
 Barrel and Cap / Clip / Ink
 OPAQUE

01/35	02/35	03/35	06/35	07/35	24/35

1195 Gold
 Barrel and Cap / Clip / Ink
 OPAQUE

02/26

MOQ: 250 U. R 250
 Ø 0,7mm ± 3 Kg



Velocity® Gel

- EN > Ultra-smooth gel roller.
Ergonomic soft touch grip.
- FR > Roller à gel ultra doux.
Grip ergonomique au toucher doux.
- ES > Roller de gel ultra suave.
Grip ergonómico de tacto suave.
- DE > Extrem sanft gleitender Gelroller.
Ergonomische Soft-Touch-Griffzone.
- IT > Roller a scrittura ultra-fluida.
Grip ergonomico morbido al tatto.



100%

1188
Gel
Gel
Gel
Gelschreiber
Gel

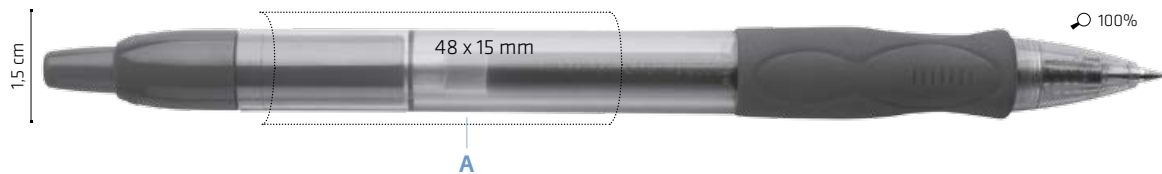

100%

A> SP: max. 1 colour

14,6 cm

Barrel / Trims / Ink
CLEAR OPAQUE



MOQ: 250 u.



Intensity® Gel Clic

NEW
INK
COLOUR

- EN > Ultra-smooth gel roller. **Automatic retracting mechanism** to avoid stains in your pocket. **Now also available with blue gel ink** and with the possibility to print **up to 4 colours!**
- FR > Roller à encre gel ultra-doux. **Mécanisme de retrait automatique** pour éviter de tacher vos poches. **Désormais disponible aussi avec encre gel bleue** et possibilité d'imprimer jusqu'à **4 couleurs !**
- ES > Roller de gel ultra suave. **Mecanismo retráctil automático** que evita las manchas en el bolsillo. **¡Ahora también disponible con tinta gel de color azul** y con la posibilidad de marcar hasta **4 colores!**
- DE > Gel-Tinte für angenehmen Schreibkomfort. **Automatischer Einzugsmechanismus**, damit in Ihrer Tasche keine Flecken entstehen. **Nun auch mit blauer Gel-Tinte** und der Möglichkeit, ihn mit **bis zu vier Farben** zu bedrucken!
- IT > Roller gel a scrittura ultra-fluida. **Meccanismo retrattile automatico** per evitare di macchiare le tasche. **Adesso disponibile anche con inchiostro gel blu** e possibilità di stampa **fino a 4 colori!**



100%

100%

100%

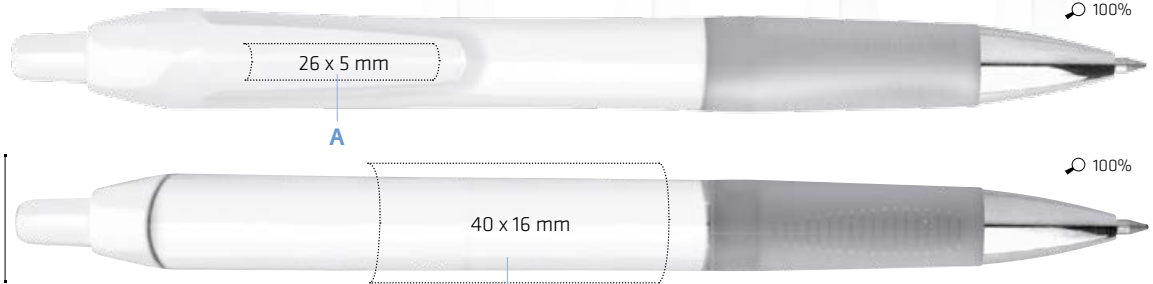

1196
Gel
Gel
Gel
Gelschreiber
Gel

A> SP: max. 2 colour
B> SP: max. 4 colours

14,8 cm

Barrel
CLEAR
86 87 88 92 93
OPAQUE
01 02

MOQ: 250 u.   250  ± 3,7 Kg
Ø 0,7mm



BY THE EXPERT
of Writing Instruments

XS Finestyle & XS Finestyle

britePix™ NEW

- EN > Super-smooth roller with Finestyle ink point. **Now also available with britePix™ full-colour concept on the clip.**
- FR > Roller super doux avec pointe feutre fine. **Désormais disponible aussi en version britePix™ toutes couleurs sur le clip.**
- ES > Roller súper fluido con punta Finestyle. **Ahora también disponible con britePix™ en el clip.**
- DE > Extrem sanft gleitender Rollerball mit Finestyle-Spitze. **Nun auch erhältlich mit britePix™-Vollfarbkonzept auf dem Clip.**
- IT > Roller a scrittura ultra-fluida con punta Finestyle. **Adesso disponibile anche con concetto di stampa a colori britePix™ sulla clip.**



1851 / 1856 Clear



1852 britePix™ / 1857 Clear britePix™



1851 /
1856 Clear /
1852 britePix™ /
1857 Clear britePix™
Finestyle

- A> PD: max. 2 colours
- B> SP: max. 2 colours
- C> BP: full colour
- D> SP: max. 1 colour

1851 / 1852
Barrel and Clip / Trims / Ink
OPAQUE



1856 / 1857 Clear
Clip, Barrel and Trims / Ink
OPAQUE / CLEAR



MOQ: 250 u.

* Only 1851 & 1856



Great Erase White Board Marker

EN > Ideal for use on **dry erase boards, glass and most non-porous surfaces.**

Easily erases with a dry cloth, tissue or felt eraser!

FR > Idéal pour une utilisation sur **tableau blanc, verre et sur la plupart des surfaces non poreuses.**

S'efface facilement avec un chiffon sec, un papier-mouchoir ou un effaceur-feutre !

ES > Ideal para usarlo en **pizarras blancas, cristal y la mayoría de superficies no porosas.**

¡Borra fácilmente con un paño seco, un pañuelo o un borrador de fieltro!

DE > Besonders für den Gebrauch auf **Whiteboards, Glas und den meisten nicht porösen Oberflächen geeignet.**

Leicht mit einem trockenen Lappen, Papiertuch oder Filzschwamm abwischbar.

IT > Ideale per **lavagne cancellabili a secco, vetro e la maggior parte delle superfici non porose.**

Si cancella facilmente con un panno asciutto, un fazzoletto o un cancellino in feltro!



BIC® WRITING INSTRUMENTS

1213
Marquer
Marqueur
Marcador
Permanent Marker
Pennarello

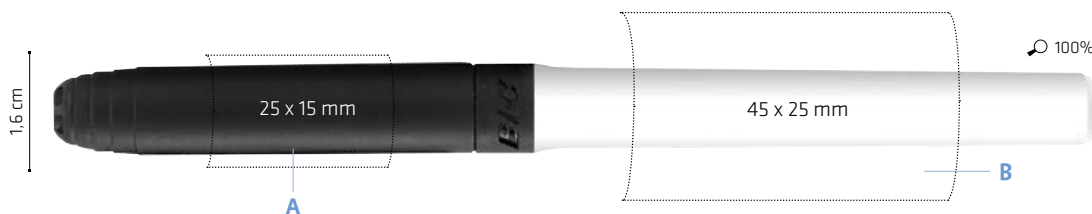

A / B > SP: max. 2 colours

13,9 cm

Barrel / Cap and Trims / Ink
OPAQUE



01/02

MOQ: 250 u.



MK 250

± 2.7 Kg



Mark-it Permanent Marker

- EN > **Fade-resistant, bright and quick-drying ink** for clean and precise writing. Textured **rubber grip** for comfort and control.
- FR > **Encre résistante, brillante et qui sèche** rapidement pour une écriture nette et précise. **Grip en caoutchouc texturé** pour un plus grand confort et contrôle.
- ES > **Tinta resistente, de un color vivo y de secado rápido** para una escritura limpia y precisa. **Grip con textura de goma** para un mayor confort y control.
- DE > **Farbechte, leuchtende und schnelltrocknende Tinte** für sauberes, präzises Schreiben. **Gummigriff** mit Reliefstruktur für mehr Komfort und Kontrolle.
- IT > **Inchiostro durevole, intenso e a rapida essiccazione** per una scrittura pulita e precisa. **Impugnatura in gomma antiscivolo** per comodità e controllo.



1214
Marqueur
Marqueur
Marcador
Permanent Marker
Pennarello

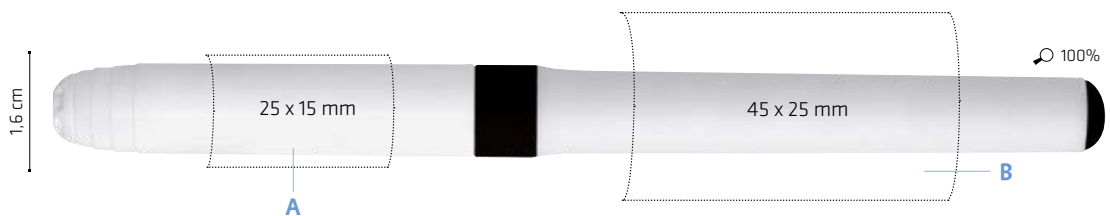

A / B > SP: max. 2 colours

13,9 cm

Barrel and Cap / Trims / Ink
OPAQUE

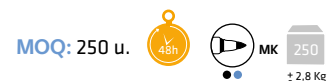

Permanent Marker



EN > Writes on most surfaces. **Quick-drying and low-odour ink.** Cap with security lock. **Large imprint area.**

FR > Il écrit sur la plupart des surfaces. **Encre qui sèche rapidement et à odeur neutre.** Capuchon doté d'une fermeture de sécurité. **Grande zone d'impression.**

ES > Escribe sobre la mayoría de superficies. **Secado rápido y olor suave.** Capuchón con cierre de seguridad. **Gran área de impresión.**

DE > Schreibt auf den meisten Oberflächen. **Schnelltrocknende, wenig parfümierte Tinte.** Verschlusskappe mit Sicherheitsverschluss. **Große Druckfläche.**

IT > Scrive su quasi tutte le superfici. **Inchiostro a rapida essiccazione e bassa emanazione di odori.** Cappuccio con chiusura di sicurezza. **Ampia area di stampa.**



100%



Plastic parts are acquired from manufacturing facilities to be reused and not discarded. (pg 178)

Plastic parts are flaked, mixed and melted.

The final result is pre-consumer recycled plastic pellets to make BIC® Ecolutions® pens.

*** Made with 51% recycled material.**

The percentage is calculated based on the total weight of the product.

Add the Mobius loop to your artwork at no additional charge. Please be sure to specify "Print the Mobius loop" on your order. (Mobius loop imprint defaults to left-hand hand corner)



100%

2 cm



65 x 45 mm

A

1210
Marquer
Marqueur
Marcador
Permanent Marker
Pennarello

A> SP: max. 1 colour

13,8 cm

Barrel / Cap / Ink
OPAQUE



MOQ: 250 u.



125

± 2,6 Kg





Brite Liner® Grip

EN > Chisel tip for **broad highlighting** and **fine underlining**. Textured **rubber grip** for comfort and control. **Highlight your message!**

FR > Pointe biseautée à **profil large pour surligner** et **fin pour souligner**. Grip en caoutchouc texturé pour un plus grand confort et contrôle. **Mettez en évidence votre message !**

ES > Punta biselada, de **perfil ancho para resaltar** o **delgado para subrayar**. **Grip de goma** para un mejor confort y control. **¡Resalta tu mensaje!**

DE > Abgeschrägte Spitze für **breites Markieren** oder **feines Unterstreichen**. **Gummierte Griffzone** mit Reliefstruktur für mehr Komfort und Kontrolle. **Machen Sie aus Ihrer Botschaft ein Highlight!**

IT > Punta a scalpello per **ampie evidenziazioni** o **precise sottolineature**. **Impugnatura in gomma antiscivolo** per comodità e controllo. **Evidenzia il tuo messaggio!**



100%

1192
Highlighter
Surligneur
Resaltador
Leuchtmarker
Evidenziatore

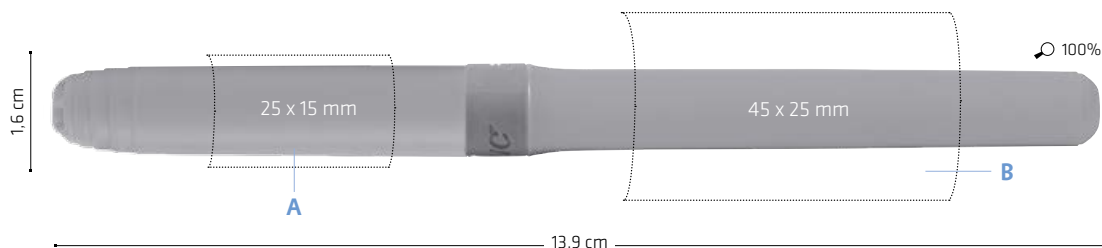

A> SP: max. 2 colours

B> SP: max. 1 colour

Barrel
OPAQUE



MOQ: 250 u.



250



± 2.8 Kg



Brite Liner® Grip XL

- EN > Make your message stand out even more on any desk by choosing the **XL** version! **Soft rubber grip.**
- FR > Optez pour la version **XL** pour faire ressortir encore davantage votre message sur n'importe quel bureau ! **Grip doux en caoutchouc.**
- ES > ¡Haz que tu mensaje destaque aún más en cualquier escritorio con el la versión **XL!** **Grip suave de goma.**
- DE > Gestalten Sie Ihre Botschaft auf dem Schreibtisch noch auffälliger durch die **XL**-Version! **Weiche Gummigriffzone.**
- IT > Fai risaltare ancora di più il tuo messaggio su tutte le scrivanie scegliendo la versione **XL!** **Impugnatura in morbida gomma.**



1193
 Highlighter
 Surligneur
 Resaltador
 Leuchtmarker
 Evidenziatore

A> SP: max. 1 colour

13,8 cm

Barrel
 OPAQUE



MOQ: 250 u.



125

± 2,8 Kg



BY THE EXPERT
of Writing
Instruments 

Set of 6 crayons
& *brite*Pix™

NEW

EN > The **ideal promotional item for children** supported by the recognised brands **BIC® Kids** and **PLASTIDECOR®**. Set of 6 **crayons** suitable for children aged 2+: **extra clean, won't stain hands or clothes resistant, and easy to sharpen!** Product **compliant** with European toy standard; tested annually by an independent lab.





Set of 6 crayons & **britePix™** NEW

FR > L'article promotionnel idéal pour les enfants soutenu par les marques favorites **BIC® Kids** et **PLASTIDÉCOR®**. Set de **6** cires qui convient aux enfants âgés de 2 ans ou plus : **très propres, elles ne tachent pas les mains ni les vêtements, résistantes et faciles à tailler!** Produit conforme à la norme européenne sur les jouets, testé annuellement par un laboratoire indépendant.

ES > El producto promocional ideal para niños con el respaldo de las marcas ganadoras: **BIC® Kids** y **PLASTIDÉCOR®**. Set de **6** ceras apropiadas para niños a partir de 2 años: **extra limpias, no manchan las manos ni la ropa, resistentes y fáciles de afilar!** Producto que cumple con normativa europea del juguete y testado anualmente por un laboratorio externo.

DE > Das ideale Werbegeschenk für Kinder, unterstützt durch die Siegermarken **BIC® Kids** und **PLASTIDÉCOR®**. Set mit **sechs** Wachsmalkreiden für Kinder ab zwei Jahren. **Besonders sauber, hinterlässt keine Flecken an den Händen oder der Kleidung, widerstandsfähig und einfach anzuspitzen!** Das Produkt erfüllt die europäische Spielzeugnorm und wird alljährlich von einem unabhängigen Labor geprüft.

IT > L'articolo promozionale ideale per bambini, supportato dai marchi di successo **BIC® Kids** e **PLASTIDÉCOR®**. Set di **6** pastelli a cera per bambini dai 2 anni in su: **pulitissimi, non macchiano le mani né gli abiti, resistenti e facili da temperare!** Prodotto conforme alla norma europea sulla sicurezza dei giocattoli, testato annualmente da un laboratorio indipendente.



1172 / 1173 **britePix™**
 Colouring crayons
 Crayons à la cire pour coloriage
 Ceras de colores
 Bunte Wachsmalkreiden
 Pastelli a cera

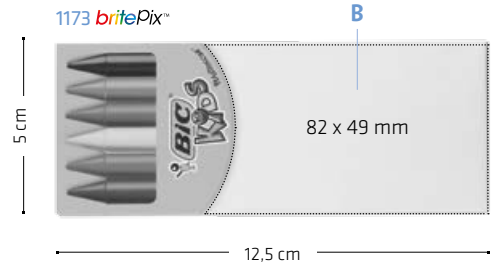
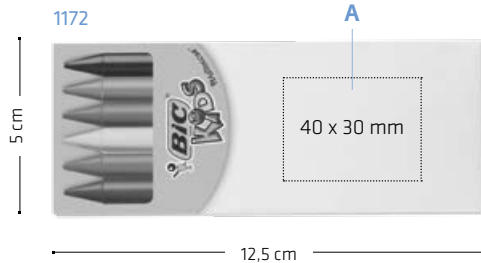

A> SP: max. 1 colour
 B> BP: full colour

BOX
 01

MOQ: 250 u. 125
 ± 6.1 Kg



Evolution Classic



- EN > **Wood-free** pencil in synthetic resin material will **not splinter** in the event of breaking and resists chewing. Resistant HB grade lead.
- FR > Crayon graphite **sans bois** en résine synthétique : **pas d'écharde** en cas de casse et résistant au mordillage. Mine HB très résistante.
- ES > Lápiz de grafito de resina sintética, **sin madera: sin astillas** al romperse y resistente al ser mordido. Mina resistente de grado HB.
- DE > Holzfreier Bleistift aus synthetischem Harz: Kein Zersplittern bei Bruch und obendrein kaubeständig. Widerstandsfähige HB-Bleimine.
- IT > Matita **senza legno** in resina sintetica: **non lascia schegge** in caso di rottura e resiste alla masticazione. Resistente mina di durezza HB.



Plastic is collected from homes, schools and businesses for recycling.



Plastic parts are acquired from manufacturing facilities to be reused and not discarded. (pg 178)



Plastic parts are flaked, mixed and melted.



The final result is pre-consumer recycled plastic to make BIC® Ecolutions® pens.

** Made with 54% recycled plastic (1150)

* Made with 46% recycled plastic (1151)

The percentage is calculated based on the total weight of the product.

Add the Möbius loop to your artwork at no additional charge. Please be sure to specify "Print the Möbius loop" on your order. (Möbius loop imprint defaults to left-hand hand corner)



1150**

Graphite pencil cut end
Crayon graphite bout coupé
Lápiz de grafito sin goma
Graphit-Bleistift ohne Radiergummi
Matita senza gomma

1151*

Graphite pencil with eraser
Crayon graphite bout gomme
Lápiz de grafito con goma
Graphit-Bleistift mit Radiergummi
Matita con gomma

A / C > SP: max. 2 colours

B / D > SP: max. 1 colour

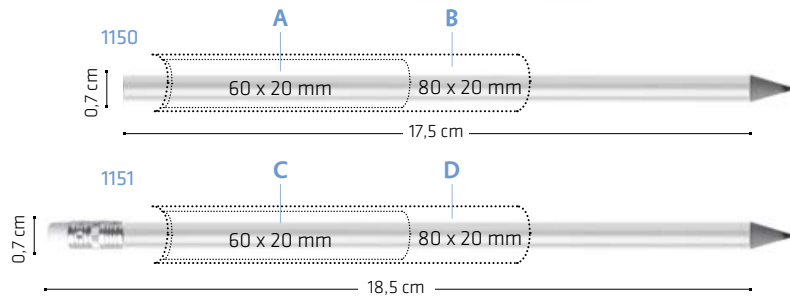

Scan this page, live the BIC Graphic Augmented Reality experience and share it!

80%

Barrel
OPAQUE



MOQ: 500 u.



HB 2,3 mm

± 3,5 Kg

*Only cut end & not sharpened



Evolution Digital



- EN > 360° photo-quality **full-colour** imprint.
- FR > Impression 360° **toutes couleurs** qualité photographique
- ES > Impresión 360° a **todo color** con calidad fotográfica.
- DE > 360°-**Vollfarbdruck** in Fotoqualität.
- IT > Stampa di qualità fotografica a **colori** a 360°.



Plastic is collected from homes, schools and businesses for recycling.



Plastic parts are acquired from manufacturing facilities to be reused and not discarded. (pg 178)



Plastic parts are flaked, mixed and melted.



The final result is pre-consumer recycled plastic to make BIC® Ecolutions® pens.

** Made with 54% recycled plastic (1879)

* Made with 46% recycled plastic (1871)

The percentage is calculated based on the total weight of the product.

Add the Möbius loop to your artwork at no additional charge. Please be sure to specify "Print the Möbius loop" on your order. (Möbius loop imprint defaults to left-hand hand corner)



80%



Scan this page, live the BIC Graphic Augmented Reality experience and share it!

1879**

- Graphite pencil cut end
- Crayon graphite bout coupé
- Lápiz de grafito sin goma
- Graphit-Bleistift ohne Radiergummi
- Matita senza gomma

1871**

- Graphite pencil with eraser
- Crayon graphite bout gomme
- Lápiz de grafito con goma
- Graphit-Bleistift mit Radiergummi
- Matita con gomma

A/C> DG: full colour (area for images)

B/D> DG: full colour (area for text)

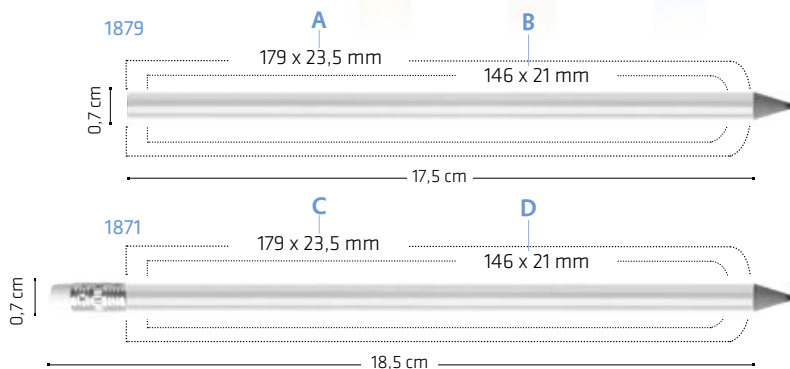

Barrel
OPAQUE

01

MOQ: 500 u. PC

500
± 3,5 Kg





Evolution

Colour Connection & Digital Colour Connection



- EN > **Mix & Match** the components and print **360° full-colour!**
- FR > Associez les composants avec **Mix & Match** et imprimez à **360° en couleur!**
- ES > ¡Combine los componentes con **Mix & Match** e imprime a **360° a todo color!**
- DE > Kombinieren Sie die Farben der Komponenten mit **Mix & Match** und wählen Sie **360°-Vollfarbdruck!**
- IT > Combina i componenti con **Mix & Match** e stampa a **360° a colori!**



Scan this page, live the BIC Graphic Augmented Reality experience and share it!

Plastic is collected from homes, schools and businesses for recycling.



Plastic parts are acquired from manufacturing facilities to be reused and not discarded. (pg 178)



Plastic parts are flaked, mixed and melted.



The final result is pre-consumer recycled plastic to make BIC® Ecolutions® pens.

*** Made with 46% recycled plastic**

The percentage is calculated based on the total weight of the product.

Add the Möbius loop to your artwork at no additional charge. Please be sure to specify "Print the Möbius loop" on your order. (Möbius loop imprint defaults to left-hand hand corner)



80%

1154 / 1885 Digital
Graphite pencil with eraser
Crayon graphite bout gomme
Lápiz de grafito con goma
Graphit-Bleistift mit Radiergummi
Matita con gomma

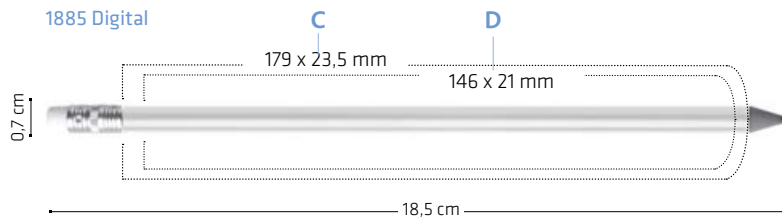
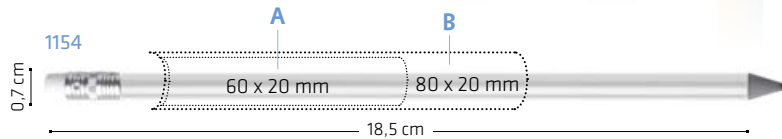

- A> SP: max. 2 colours
- B> SP: max. 1 colour
- C> DG: full colour (area for images)
- D> DG: full colour (area for text)



1154 Barrel OPAQUE

01	02	03
04	07	20

1885 Barrel OPAQUE

01

1154 / 1885 Eraser Ferrule

01	02	07	10	02	2C	24
12	14	59	34	47		

MOQ: 500 u. PC

500 + 3,5 Kg





Matic® & Matic® Quartz

- EN > Provides write-out **equivalent to 2^{1/2} woodcase pencils! Scantron Certified** to be used on forms, in tests or with machine-readable questionnaires. **Three 0.7 mm #2 graphite leads** (HB). Clear and metallic colours available.
- FR > Offre une durée d'écriture **2,5 fois supérieure aux crayons de bois ! Certifié Scantron** pour utilisation sur des formulaires, tests ou questionnaires lisibles par machine. **Trois mines de graphite n° 2 de 7 mm** (HB). Disponible en couleurs claires et métalliques.
- ES > ¡Proporciona una longitud de escritura **equivalente a 2,5 lápices de madera! Certificado por Scantron** para uso en formularios, test o cuestionarios de lectura automática. **Tres recambios de grafito de 0,7 mm** (HB). Disponible en colores clear y metálicos.
- DE > Entspricht einer Schreiblänge von **zweieinhalb Holzbleistiften! Scantron-geprüft:** geeignet für Fragebögen, Examina und Lesemaschinen. **Drei 0,7 mm Graphit-Minen** (HB). In klarsichtigen und Metallfarben verfügbar.
- IT > Fornisce una durata di scrittura equivalente a **2 volte e mezzo una normale matita in legno! Certificato Scantron**, lettore di marcature ottiche usato per valutazione di esami universitari, test e questionari ufficiali. **Tre mine in grafite da 0,7 mm** (HB). Disponibile in colori trasparenti e metallizzati.



Scan this page, live the BIC Graphic Augmented Reality experience and share it!

1120
1121 Quartz/
1124 Quartz Metallic
Mechanical pencil
Porte-mine
Portaminas
Druckbleistift
Portamine

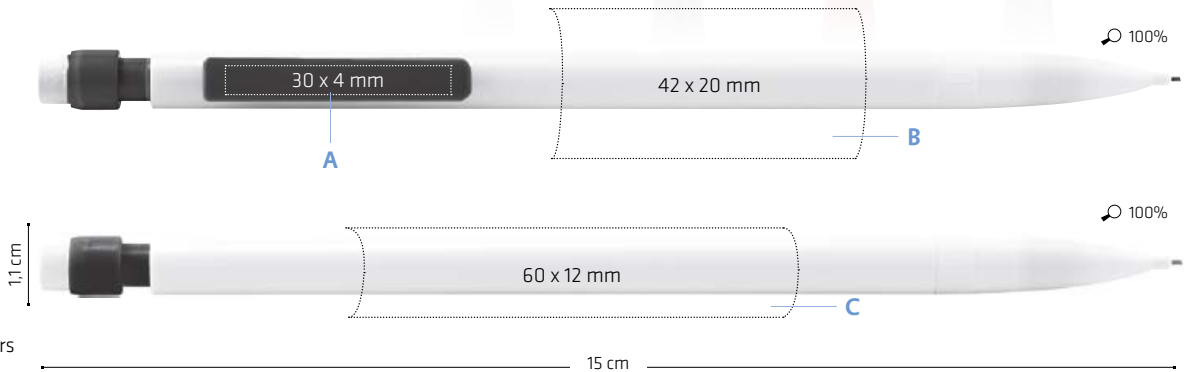

A> SP: max. 1 colour
B/C> SP: max. 2 colours

1120
Barrel and Trims
OPAQUE

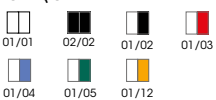

1121 Quartz
Barrel and Trims
OPAQUE

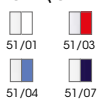

1124 Quartz Metallic
Barrel and Trims
OPAQUE



MOQ: 500 u.



500
± 3,1 Kg



BIC eSolutions
Recycled Content
Option pg 194*
* 1120



Matic® Grip

EN > Comfortable **soft touch rubber grip**. Opaque, clear and metallic colours available.

FR > **Grip confortable en caoutchouc doux**. Disponible en couleurs opaques, claires et métalliques.

ES > Confortable **grip de goma de tacto suave**. Colores clear, opacos y metálicos disponibles.

DE > Komfortable **Soft-Touch Gummigriffzone**. Opake, klarsichtige und Metallic-Farben verfügbar.

IT > Impugnatura con **grip in morbida gomma**. Disponibile in colori opachi, trasparenti e metallizzati



Scan this page, live the BIC Graphic Augmented Reality experience and share it!

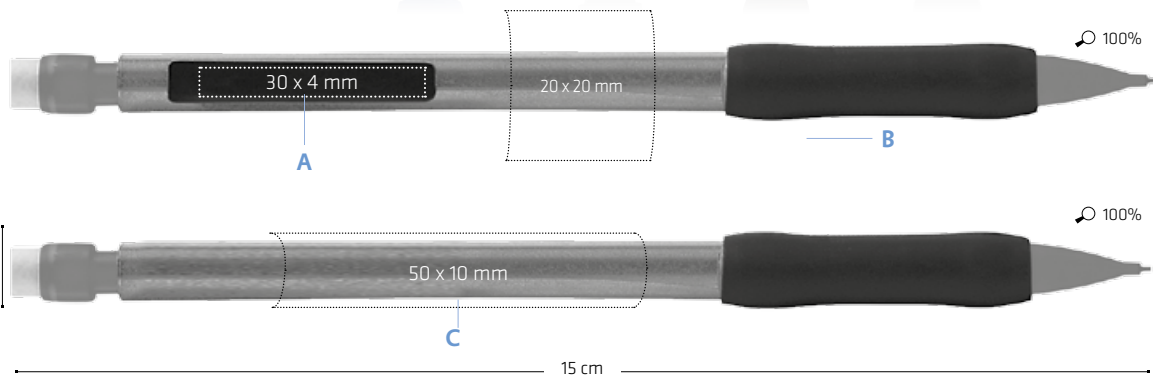

1122 / 1127 Metallic
Mechanical pencil
Porte-mine
Portaminas
Druckbleistift
Portamine

A> SP: max. 1 colour

B/C> SP: max. 2 colours

1122
Barrel / Trims
OPAQUE



1127 Metallic
Barrel / Trims
OPAQUE



MOQ: 500 u.





Clic Matic

- EN > **Side lead advance mechanism.**
Scantron Certified to be used in forms, test or machine-readable questionnaires.
Textured rubber grip for comfort and control.
- FR > **Mécanisme latéral d'avance de mine.**
Certifié Scantron pour utilisation sur des formulaires, tests ou questionnaires lisibles par machine.
Grip en caoutchouc texturé pour plus de confort et de contrôle d'écriture.
- ES > **Mecanismo lateral de avance de la mina.**
Certificado por Scantron para uso en formularios, test o cuestionarios de lectura automática.
Grip de goma con relieve para comodidad y control.
- DE > **Seitlicher Druckmechanismus für Minentransport.**
Scantron-geprüft: geeignet für Fragebögen, Examina und Lesemaschinen.
Weiche strukturierte Gummi-Griffzone für komfortables, sicheres Schreiben.
- IT > **Meccanismo laterale di avanzamento della mina.**
Certificato Scantron, lettore di marcature ottiche usato per valutazione di esami universitari, test e questionari ufficiali.
Grip in gomma ruvida per il massimo comfort.



1126
Mechanical pencil
Porte-mine
Portaminas
Druckbleistift
Portamine



A> SP: max. 2 colours 15 cm

Barrel
OPAQUE
01

MOQ: 500 u.
Ø0,7mm ± 2,5 Kg



Slim Metal

- EN > Curved clip design.
Shiny nickel, satin chrome attributes.
Metallic finish.
- FR > Clip au design incurvé.
Attributs en chrome satiné et nickel brillant.
Fini métallisé.
- ES > Diseño curvado del clip.
Niquelado brillante, atributos cromados satinados.
Acabado metálico.
- DE > Gebogenes Clip-Design.
Glänzend vernickelte und satinierte Chromelemente.
Metallic-Finish.
- IT > Design con clip curva.
Puntale e clip cromati, fusto satinato.
Finitura metallizzata.



1942
Ballpen
Bille
Bolígrafo
Kugelschreiber
Penna a sfera

A > LE.
B > SP: max. 1 colour

13.8 cm

Barrel / Ink



MOQ: 50 u.



M

150

± 3.7 Kg

Standard Packaging: Black velvet pouch for 1 item
Optional Packaging: (pg 218)



Pivo[®] Metal

- EN > Elegant metal silver colour pen with matching colour trim.
- FR > Élégant stylo métallique de couleur argentée avec attributs assortis.
- ES > Elegante bolígrafo metálico de color plateado con atributos a juego.
- DE > Eleganter, silberner Metallkugelschreiber mit farblich passender Zierleiste.
- IT > Elegante penna in metallo argentato con dettaglio abbinato.



BIC® WRITING INSTRUMENTS

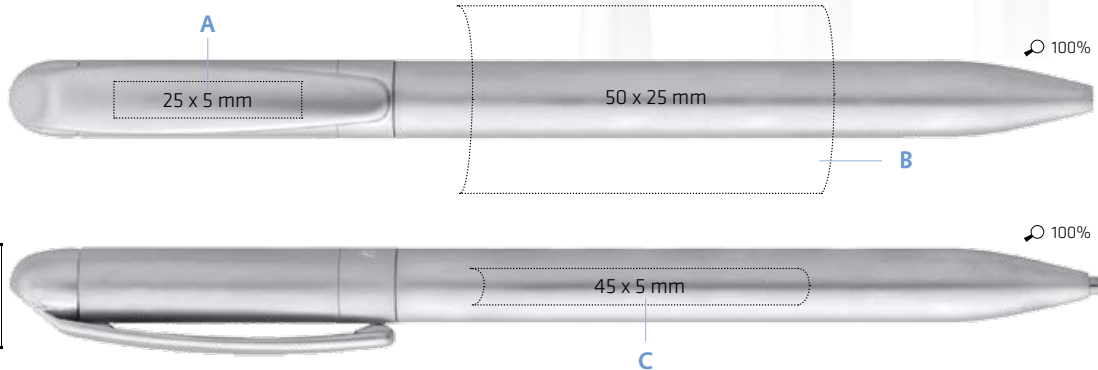

1280
Ballpen
Bille
Bolígrafo
Kugelschreiber
Penna a sfera

A/B> SP: max. 1 colour
C> LE: right, left & clip centred

Barrel / Ink



MOQ: 50 u. ± 4.2 Kg

Standard Packaging: Black velvet pouch for 1 item
Optional Packaging: (pg 218)



Wide Body™ Metal

- EN > Wide-profile, all-metal construction. Satin chrome-plated trim.
- FR > Modèle à profil large tout en métal. Corps chromé satiné.
- ES > Línea ancha, todo de metal. Atributos cromados satinados.
- DE > Breiter Schaft aus Metall. Beschläge verchromt und satiniert.
- IT > Ampio profilo, completamente in metallo. Finiture cromate satinata.



- 1285**
Ballpen
Bille
Bolígrafo
Kugelschreiber
Penna a sfera

- 1287**
Mechanical pencil
Porte-mine
Portaminas
Druckbleistift
Portamine

A/B > LE
E > LE: right, left & rear clip
C/D/F > SP: max. 1 colour

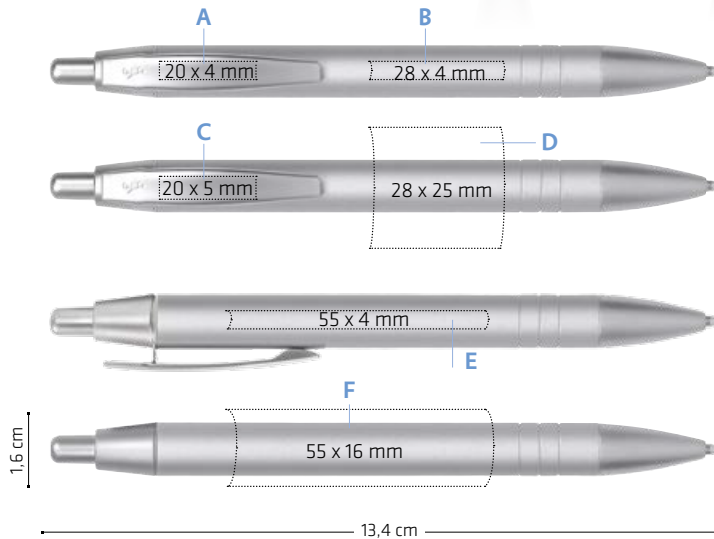

Barrel / Ink



MOQ: 50 u. 150

Standard Packaging: Black velvet pouch for 1 item
Optional Packaging: (pg Z18)



Wide Body™ Metal Grip

- EN > Elegance and comfort with its 3-sided grip.
- FR > Élégance et confort avec son grip à 3 côtés.
- ES > Elegancia y confort con su grip de 3 lados.
- DE > Eleganz und Schreibkomfort durch die 3-kantige Griffzone.
- IT > Eleganza e confort con grip triangolare.



BIC® WRITING INSTRUMENTS

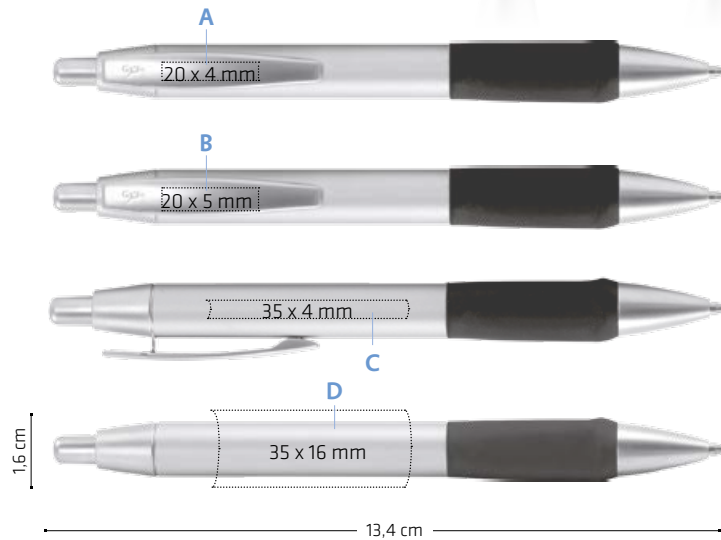

1286
Ballpen
Bille
Bolígrafo
Kugelschreiber
Penna a sfera

A > LE
C > LE: right, left & rear clip
B/D > SP: max. 1 colour

Barrel / Ink

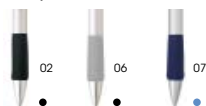

MOQ: 50 u.



± 4,5 Kg

Standard Packaging: Black velvet pouch for 1 item
Optional Packaging: (pg 218)



Rondo Style Classic & Rubberised

1274 / 1276

- EN > Classic and elegant style. Available in ballpen and pencil: make **your own gift pen set!**
- FR > Style classique et élégant. Disponible en version stylo à bille et porte-mine. Composez **votre propre set cadeau !**
- ES > De estilo elegante y clásico. Disponible en bolígrafo y portaminas: ¡Crea **tu propio set de regalo!**
- DE > Klassisch-eleganter Stil. Als Kugelschreiber und Bleistift erhältlich. Gestalten Sie **Ihr eigenes Stifte-Geschenkset!**
- IT > Stile classico e raffinato. Disponibile in versione penna a sfera e portamine: componi **il tuo set regalo da scrittura!**

1274 /
1275 Rubberised

Ballpen
Bille
Bolígrafo
Kugelschreiber
Penna a sfera

1276 /
1277 Rubberised
Mechanical pencil
Porte-mine
Portaminas
Druckbleistift
Portamine

- A > PD: max. 1 colour
B > LE
C > SP: max. 4 colours
D > SP: max. 2 colours
E > SP: max. 1 colour

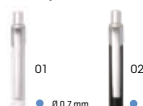
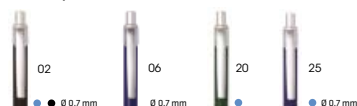
1274 / 1276
Barrel / Ink1275 Rubberised / 1277 Rubberised
Barrel / Ink

1275 Rubberised / 1277 Rubberised

- EN > Soft rubberised barrel. Available in ballpen and pencil: make **your own gift pen set!**
- FR > Corps en caoutchouc souple. Disponible en version stylo à bille et porte-mine. Composez **votre propre set cadeau !**
- ES > Con cuerpo aterciopelado. Disponible en bolígrafo y en portaminas: ¡Crea **tu propio set de regalo!**
- DE > Weicher, gummierter Schaft. Als Kugelschreiber und Bleistift erhältlich. Gestalten Sie **Ihr eigenes Stifte-Geschenkset!**
- IT > Morbido fusto gommato. Disponibile in versione penna a sfera e portamine: componi **il tuo set regalo da scrittura!**

1274 / 1276

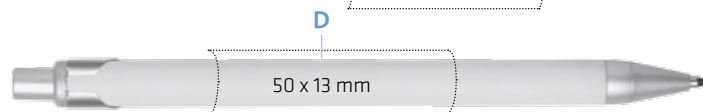
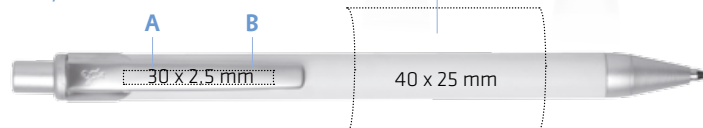

1275 Rubberised / 1277 Rubberised

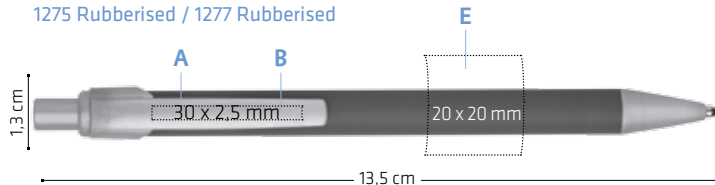

MOQ: 50 u.



Standard Packaging: Black velvet pouch for 1 item
Optional Packaging: (pg 218)



Protrusion Grip

- EN > Comfortable soft grip with polished **chrome-plated steel clip**.
- FR > Grip en relief au toucher doux avec **clip en acier chromé poli**.
- ES > Suave grip en relieve con **clip y atributos de acero bañados en cromo**.
- DE > Profilierte Griffzone mit **verchromtem Clip**.
- IT > Impugnatura morbida e confortevole con **clip in acciaio cromato**.



BIC® WRITING INSTRUMENTS

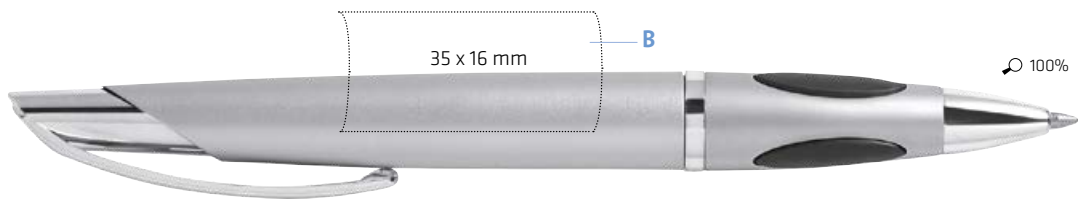
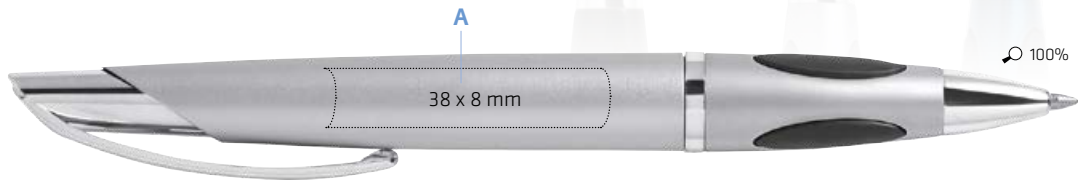

1836
Ballpen
Bille
Bolígrafo
Kugelschreiber
Penna a sfera

1,7 cm

A> LE: right & left clip
B> SP: max. 1 colour

13,7 cm

Barrel / Ink

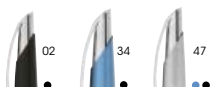

MOQ: 50 u. ± 4,7 Kg

Standard Packaging: Black velvet pouch for 1 item
Optional Packaging: (pg 218)



Attriant®

- EN > Polished finish with chrome-coloured trim.
- FR > Finition polie avec attributs de couleur chromée.
- ES > Acabado pulido con atributos de color cromado.
- DE > Polierte Ausführung mit chromfarbiger Zierleiste.
- IT > Finitura lucida con particolari color cromo.



1840
Ballpen
Bille
Bolígrafo
Kugelschreiber
Penna a sfera



A> LE: right & left clip
B> SP: max. 1 colour

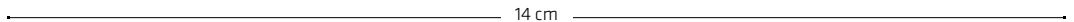

Barrel / Ink



MOQ: 50 u. ± 4.7 Kg

Standard Packaging: Black velvet pouch for 1 item
Optional Packaging: (pg 218)



Tri-Tone Twist

- EN > Satin chrome and nickel-plated trim.
- FR > Attributs en chrome satiné et nickel.
- ES > Atributos cromado satinados y plateado niquelados.
- DE > Komponenten aus satiniertem Chrom und vernickelte Elemente.
- IT > Finiture cromo satinato e nickel.



1943
Ballpen
Bille
Bolígrafo
Kugelschreiber
Penna a sfera

- A> LE: right, left & rear clip
- B> LE*: right, left, rear & clip centred
- C> SP: max. 1 colour

Barrel / Ink
LACQUER FINISH





* LE not available on blue barrel

MOQ: 50 u. ±4.7 Kg

Standard Packaging: Black velvet pouch for 1 item
Optional Packaging: (pg 218)

Sheaffer® Ballpens

	Sheaffer® 100	129
	Sheaffer® 300	126
	Sheaffer® 500	127
	Sheaffer® Intensity®	123
	Sheaffer® Legacy® Heritage	116
	Sheaffer® Prelude® Black Laque	120
	Sheaffer® Prelude® Black Laque & Palladium Cap	118
	Sheaffer® Prelude® Brushed Chrome	121
	Sheaffer® Prelude® Brushed Chrome Gold	119
	Sheaffer® Prelude® Mini	122
	Sheaffer® Sagaris® Chrome trim	124
	Sheaffer® Sagaris® Gold tone trim	125
	Sheaffer® Sentinel®	131
	Sheaffer® Sentinel® Colours	132
	Sheaffer® Stylus	128
	Sheaffer® Taranis®	117
	Sheaffer® VFM	130

Sheaffer® Rollers

	Sheaffer® Intensity®	123
	Sheaffer® Prelude® Black Laque	120
	Sheaffer® Prelude® Brushed Chrome	121
	Sheaffer® Sagaris® Chrome trim	124
	Sheaffer® VFM	130

Sheaffer® Fountain Pens

	Sheaffer® Legacy® Heritage	116
	Sheaffer® Prelude® Brushed Chrome	121
	Sheaffer® Taranis®	117



Sheaffer® Mechanical Pencils

	Sheaffer® 100	129
	Sheaffer® 300	126
	Sheaffer® Prelude® Brushed Chrome	121
	Sheaffer® Sentinel®	131
	Sheaffer® Sentinel® Colours	132

Sheaffer® Padfolios & Accessories

	Sheaffer® Classic Bi-Fold Wallet	134
	Sheaffer® Classic Junior Padfolio	135
	Sheaffer® Classic Mini Pad	134
	Sheaffer® Classic Padfolio	135
	Sheaffer® Classic Tablet Holder	136
	Sheaffer® Classic Travel Wallet	137

Sheaffer® Travel

	Sheaffer® Classic 4 wheeled carry-on	142
	Sheaffer® Classic Business Backpack	139
	Sheaffer® Classic Business Briefcase	138
	Sheaffer® Classic Business Weekender	143
	Sheaffer® Garment Bag	141
	Sheaffer® Travel Briefcase	140



SHEAFFER®

SHEAFFER® LEGACY® *Heritage*

EN > Classic styling and wide profile.
The fountain pen features the **exclusive Inlaid Nib** - a Sheaffer® original design from 1959 - in palladium plate. Sheaffer® Limited **Lifetime Warranty**.

FR > Style classique et profil large.
Le stylo plume possède une **pointe incrustée**, design original et exclusif de Sheaffer® depuis 1959, plaqué palladium.
Garantie à vie Sheaffer®.

ES > Estilo clásico y perfil ancho.
La pluma estilográfica incluye la **exclusiva punta incrustada** - de diseño original de Sheaffer® desde 1959 - bañada en paladio.
Garantía Sheaffer® **de por vida**.

DE > Klassischer Stil, breites Profil.
Füllfederhalter mit **exklusiver Intarsienfeder** - ein Original-Sheaffer®-Design seit 1959 - mit Palladiumbad.
Limitierte Sheaffer®-**Garantie auf Lebenszeit**.

IT > Stile classico e sezione larga.
La penna stilografica include l'**esclusiva punta intarsiata** - di design originale Sheaffer® dal 1959 - placcata in palladio.
Garanzia a vita Sheaffer®.



1510
Fountain Pen
Stylo Plume
Pluma
Füllfederhalter
Penna stilografica

1512
Ballpen
Bille
Bolígrafo
Kugelschreiber
Penna a sfera

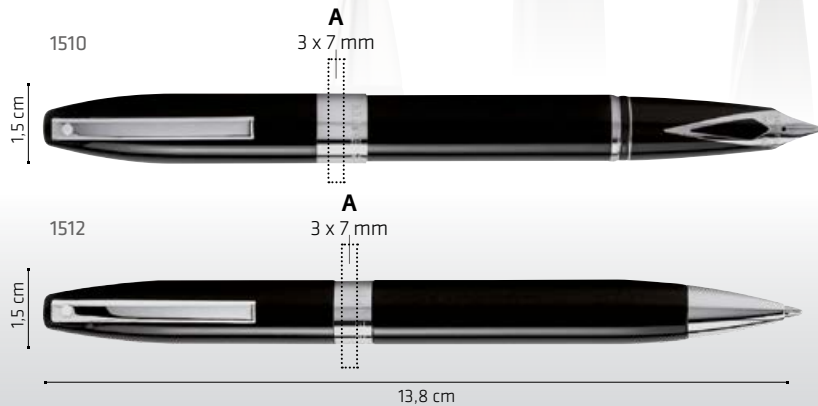

A > LE

Finishes

 Black laque /
Palladium plate trim



MOQ: 1 u.



± 1.9 Kg

Standard Packaging: Sheaffer® Premium Gift Box (pg 221)
Optional Packaging: pg 221

SHEAFFER® TARANIS®

EN > **Designed by** renowned U.S. architect **Charles Debbas**, the Sheaffer® Taranis® design and finishes provide the balance between the classic and the modern. **The gripping section** combines the warmth of resin and the durability of metal. Sheaffer® Limited **3 Year Warranty**.

FR > **Conçues par** le célèbre architecte américain **Charles Debbas**, les formes et finitions du Sheaffer® Taranis® subliment l'équilibre entre classique et moderne. **Section brevetée associant** le côté chaleureux de la résine à la durabilité du métal. **Garantie Sheaffer® de 3 ans.**

ES > **Diseñado por** el reconocido arquitecto estadounidense **Charles Debbas**, los diseños y acabados de Sheaffer® Taranis® subliman el equilibrio entre lo clásico y lo moderno. **Sección patentada** que combina la calidez de la resina con la durabilidad del metal. **Garantía Sheaffer® de 3 años.**

DE > Vom renommierten US-amerikanischen Architekten **Charles Debbas entworfen**. Die Designs und Finishes von Sheaffer® Taranis® finden das perfekte Gleichgewicht zwischen Klassik und Moderne. **Die patentierte Griffzone** kombiniert die Wärme von Harz mit der Haltbarkeit von Metall. **3 Jahre** limitierte Sheaffer®-**Garantie.**

IT > **Progettate dal** famoso architetto americano **Charles Debbas**, il design e le finiture della Sheaffer® Taranis® sublimano l'equilibrio tra il classico e il moderno. **Puntale brevettato** che combina il calore della resina alla resistenza del metallo. **Garanzia Sheaffer® di 3 anni.**



- 1458
Ballpen
Bille
Bolígrafo
Kugelschreiber
Penna a sfera
- 1459
Fountain Pen
Stylo Plume
Pluma
Füllfederhalter
Penna stilografica



A / B > LE: right, left & rear clip

Finishes

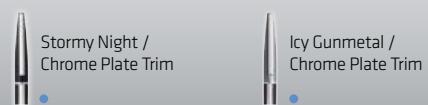

48h MOQ: 1 U. M FP 8 + 2,2 Kg

Standard Packaging: Sheaffer® Premium Gift Box (pg 221)
Optional Packaging: pg 221

SHEAFFER

Prelude®

COLLECTION

EN > Comfortable and balanced profile.
Black onyx laque barrel, chased palladium plate cap featuring **22K gold-plated trim**.
Sheaffer® Limited **Lifetime Warranty**.

FR > Profil confortable et équilibré.
Corps noir brillant laqué, capuchon plaqué palladium et **détails en or 22 K**.
Garantie à vie Sheaffer®.

ES > Perfil confortable y equilibrado.
Cuerpo negro brillante lacado, capuchón bañado en paladio y **atributos en oro de 22K**.
Garantía Sheaffer® **de por vida**.

DE > Ausgewogenes und komfortables Profil. Glanzlackierter schwarzer Schaft, Kappe mit Palladiumbad und Verzierungen mit **22-Karat-Vergoldung**.
Limitierte Sheaffer® **Garantie auf Lebenszeit**.

IT > Profilo con facile impugnatura.
Corpo laccato nero lucido, cappuccio placcato in palladio e **finiture placcate in oro 22K**.
Garanzia a vita Sheaffer®.

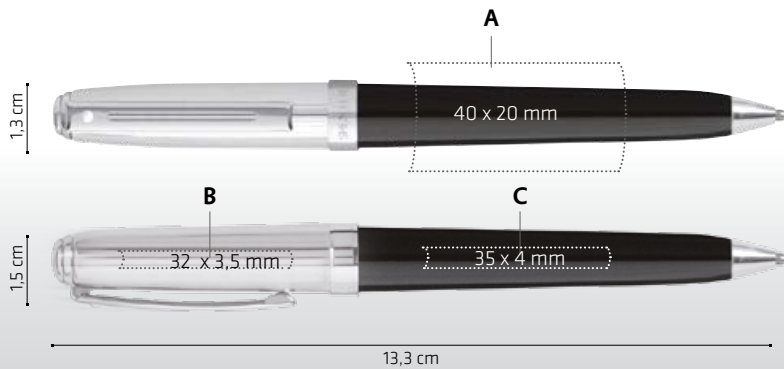

1416
Ballpen
Bille
Bolígrafo
Kugelschreiber
Penna a sfera



A> SP: max. 1 colour
B> LE: only right clip
C> LE: clip centred, rear clip, right & left

Finishes

Black laque barrel /
Palladium plate cap /
22K Gold plate trim



MOQ: 1 u.



± 2,7 Kg

Standard Packaging: Sheaffer® Luxury Gift Box (pg 221)
Optional Packaging: pg 221

SHEAFFER.

Prelude®

COLLECTION

EN > Luxury **22K gold-plated trim finish.**
Sheaffer® Limited **Lifetime Warranty.**

FR > Luxueux **attributs plaqués or 22 carats.**
Garantie à vie Sheaffer®.

ES > Lujosos **acabados bañados en oro de 22 quilates.**
Garantía Sheaffer® **de por vida.**

DE > Luxuriöse **Goldausführung in 22 Karat.**
Limitierte Sheaffer® **Garantie auf Lebenszeit.**

IT > Pregiate **finiture placcate in oro 22 carati.**
Garanzia a vita Sheaffer®.

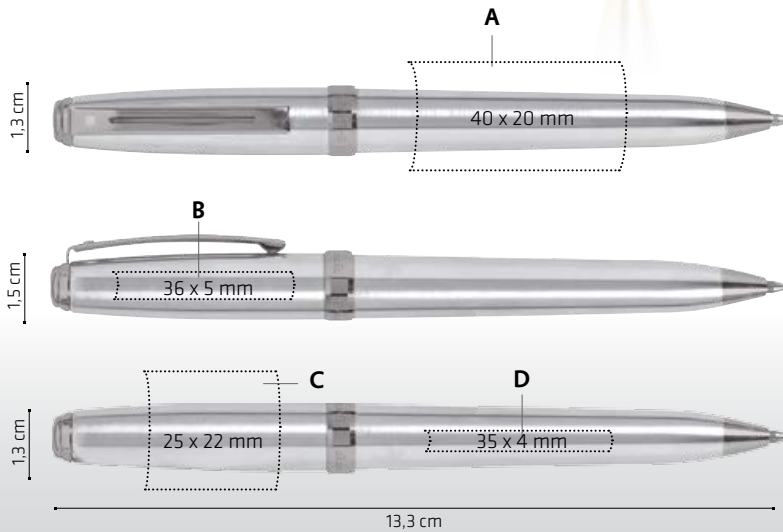

A / C > SP: max. 1 colour
B > LE: right, left & rear clip
D > LE: clip centred, rear clip, right & left

1530
Ballpen
Bille
Bolígrafo
Kugelschreiber
Penna a sfera

Finishes

 Brushed Chrome /
22K Gold Plate Trim



MOQ: 1 u.



+ 2.7 Kg

Standard Packaging: Sheaffer® Luxury Gift Box (pg 221)
Optional Packaging: pg 221

SHEAFFER

Prelude®

COLLECTION

EN > **Black laque** finish featuring **nickel-plated trim**.
Sheaffer® Limited **Lifetime Warranty**.

FR > Finition **noire laquée** avec **détails nickelés**.
Garantie à vie Sheaffer®.

ES > Acabado en **negro lacado** con **atributos niquelados**.
Garantía Sheaffer® **de por vida**.

DE > **Schwarzlackiertes** Finish mit **vernickelten Verzierungen**.
Sheaffer® **Garantie auf Lebenszeit**.

IT > Finitura **laccata nera** con **particolari nichelati**.
Garanzia a vita Sheaffer®.



1406 / 1407

1.5 cm

A

40 x 20 mm

1406
Roller Ball
Stylo roller
Roller
Rollerball
Roller

1.5 cm

B

36 x 5 mm

1407
Ballpen
Bille
Bolígrafo
Kugelschreiber
Penna a sfera

1.5 cm

C

35 x 4 mm

13,3 cm



A SP: max. 1 colour
B> LE: right, left & rear clip
C> LE: clip centred, rear clip, right & left

Finishes



MOQ: 10 U.



+ 2.7 Kg

Standard Packaging: Sheaffer® Luxury Gift Box (pg 221)
Optional Packaging: pg 221

SHEAFFER.

Prelude®

COLLECTION

EN > **Brushed chrome-plated** finish featuring **nickel-plated trim.**
Sheaffer® Limited **Lifetime Warranty.**

FR > Finition **chromée avec compléments nickelés.**
Garantie à vie Sheaffer®.

ES > Acabado **cromado con complementos niquelados.**
Garantía Sheaffer® **de por vida.**

DE > **Verchromtes** Finish mit **vernickelten Verzierungen.**
Sheaffer® **Garantie auf Lebenszeit.**

IT > Finitura **cromata con particolari nichelati.**
Garanzia a vita Sheaffer®.



1532
Fountain Pen
Stylo Plume
Pluma
Füllfederhalter
Penna stilografica

1533
Roller Ball
Stylo roller
Roller
Rollerball
Roller

1534
Ballpen
Bille
Bolígrafo
Kugelschreiber
Penna a sfera

1535
Mechanical pencil
Porte-mine
Portaminas
Bleistift
Portamine

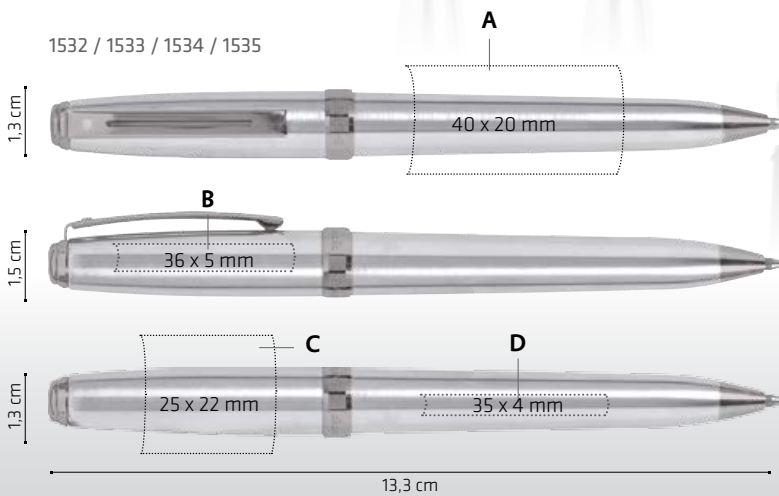

A / C > SP: max. 1 colour
B > LE: right, left & rear clip
D > LE: clip centred, rear clip, right & left
(not available for 1532)



Finishes

Brushed Chrome /
Nickel Plate trim
● Ø 0,7 mm



MOQ: 10 U.



Standard Packaging: Sheaffer® Luxury Gift Box (pg 221)
Optional Packaging: pg 221

SHEAFFER

Prelude® COLLECTION

Mini

- EN > Mini, **portable version of the classic Prelude® Collection.**
Easy twist action mechanism.
Sheaffer® Limited **3 Year Warranty.**
- FR > Mini **version portable de la collection classique-Prelude®** la plus vendue.
Mécanisme pivotant.
Garantie Sheaffer® de 3 ans.
- ES > Versión mini del **más vendido de la colección Prelude®.**
Fácil mecanismo pivotante.
Garantía limitada Sheaffer® de 3 años.
- DE > Mini-**Version aus der klassischen Prelude®-Kollektion.**
Einfacher Drehmechanismus.
3 Jahre limitierte Sheaffer®-**Garantie.**
- IT > Versione mini della **classica collezione Prelude®.**
Semplice meccanismo a rotazione.
Garanzia Sheaffer® di 3 anni.

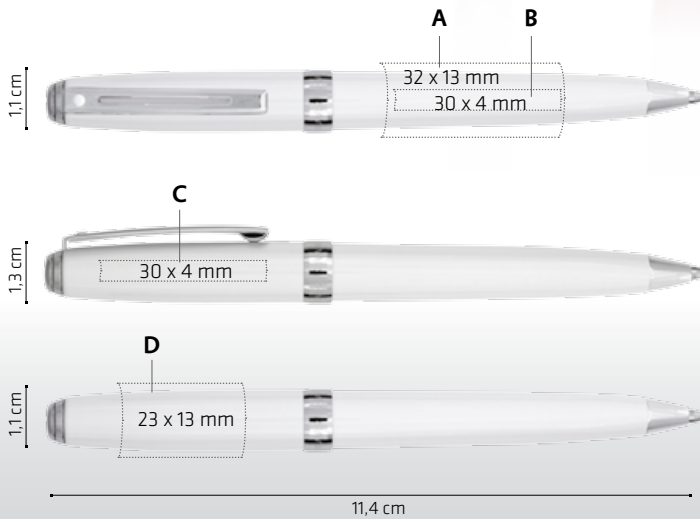

1519
Ballpen
Bille
Bolígrafo
Kugelschreiber
Penna a sfera



A / D > SP: max. 1 colour
B > LE
C > LE: right, left & rear clip

Finishes



MOQ: 10 u.



+ 2.5 Kg

Standard Packaging: Sheaffer® Luxury Gift Box (pg 221)
Optional Packaging: pg 221

SHEAFFER® INTENSITY®

EN > **Sleek and streamlined design** offered in two contemporary finishes: **onyx and carbon fibre**, both featuring chrome-plated trim. Sheaffer® Limited **3 Year Warranty**.

FR > **Forme stylisée** disponible dans deux finitions contemporaines : **onyx et fibre de carbone**, toutes deux avec des finitions chromées. **Garantie Sheaffer® de 3 ans.**

ES > **Diseño estilizado** disponible en dos acabados contemporáneos: **ónix y fibra de carbono**, ambos con acabados cromados. **Garantía Sheaffer® de 3 años.**

DE > **Elegantes, schnittiges Design** mit zwei modernen Finishes: **Onyx und Kohlefaser**, beide mit verchromten Verzierungen. **3 Jahre** limitierte Sheaffer®-**Garantie.**

IT > **Design stilizzato** disponibile in due finiture contemporanee: **onice e fibra di carbonio**, entrambe con finiture cromate. **Garanzia Sheaffer® di 3 anni.**

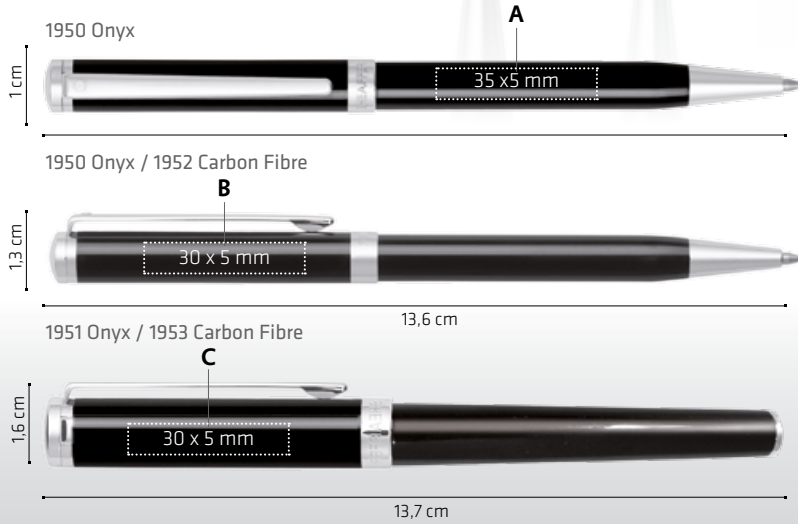

A > LE
B / C > LE: right, left & rear clip

Finishes



Standard Packaging: Sheaffer® Luxury Gift Box (pg 221)
Optional Packaging: pg 221

SHEAFFER®
SAGARIS®

EN > **Classic and timeless style** reminiscent of vintage Sheaffer® writing instruments. Elegant and sophisticated finishes with **chrome-plated trim**. Sheaffer® Limited **3 Year Warranty**.

FR > **Forme classique et intemporelle** évoquant les instruments classiques d'écriture Sheaffer®. Finitions élégantes avec **détails chromés**. **Garantie Sheaffer® de 3 ans**.

ES > **Diseño clásico y atemporal** evocador de los clásicos instrumentos de escritura Sheaffer®. Acabados elegantes con **atributos cromados**. **Garantía Sheaffer® de 3 años**.

DE > **Klassischer, zeitloser Stil**, der Erinnerungen an die Sheaffer®-Vintageschreibgeräte wachruft. Elegante Finishes mit **verchromten Verzierungen**. **3 Jahre** limitierte Sheaffer®-Garantie.

IT > **Design intramontabile** che ricorda i classici strumenti da scrittura Sheaffer®. Finiture eleganti con **particolari cromati**. **Garanzia Sheaffer® di 3 anni**.

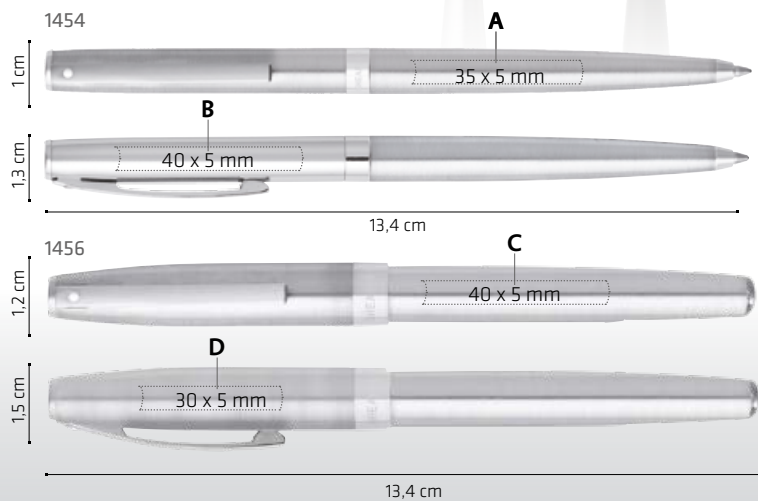

1454
Ballpen
Bille
Bolígrafo
Kugelschreiber
Penna a sfera

1456
Roller Ball
Stylo roller
Roller
Rollerball
Roller



A / C > LE: clip centred & rear clip
B / D > LE: right, left & rear clip

Finishes



MOQ: 25 U.



+ 2.5 Kg

Standard Packaging: Sheaffer® Luxury Gift Box (pg 221)
Optional Packaging: pg 221

SHEAFFER®

SAGARIS®

- EN > Gloss black or brushed chrome colours featuring luxurious **gold tone trim**. Sheaffer® Limited **3 Year Warranty**.
- FR > Corps couleur chromé ou noir brillant et **finitions couleur or**. **Garantie Sheaffer® de 3 ans**.
- ES > Cuerpo en color cromado o negro brillante combinado con **acabados en color oro**. **Garantía Sheaffer® de 3 años**.
- DE > Chromfarbener oder glänzend schwarzer Schaft kombiniert mit luxuriösen **goldfarbenen Verzierungen**. **3 Jahre** limitierte Sheaffer®-**Garantie**.
- IT > Corpo nero lucido o cromato spazzolato abbinato a **finiture dorate**. **Garanzia Sheaffer di 3 anni**.

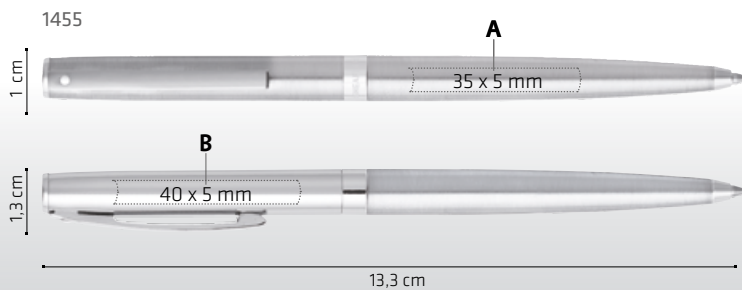

1455
Ballpen
Bille
Bolígrafo
Kugelschreiber
Penna a sfera



A> LE
B> LE: right, left & rear clip

Finishes



Brushed Chrome /
Gold Tone trim



Black barrel /
Chrome cap /
Gold Tone trim



MOQ: 25 U.



M



± 2.5 Kg

Standard Packaging: Sheaffer® Luxury Gift Box (pg 221)
Optional Packaging: pg 221



SHEAFFER®

Sheaffer® 300

EN > **Modern design** and elegant finishes personify elegance. **New colours** available. Sheaffer® Limited **1 Year Warranty**.

FR > **Design moderne** et finitions subtiles incarnant l'élégance. **Nouvelles couleurs** disponibles. **Garantie limitée Sheaffer® de 1 an**.

ES > **Diseño moderno** con acabados sutiles que personifican la elegancia. **Nuevos colores** disponibles. **Garantía Sheaffer® de 1 año**.

DE > **Modernes Design** mit subtilen Details, die Eleganz widerspiegeln. **Neue Farben** erhältlich. **1-Jahr** limitierte Sheaffer®-Garantie.

IT > **Moderno design** con eleganti finiture. **Nuovi colori** disponibili. **1 anno di garanzia** Sheaffer®.



1556

NEW COLOUR



1556

NEW COLOUR

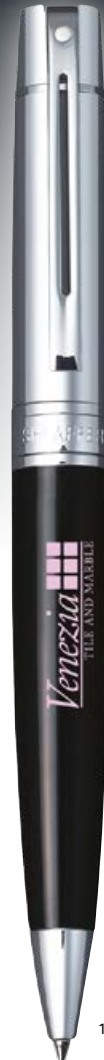

1558



1557

100%

1556
Ballpen
Bille
Bolígrafo
Kugelschreiber
Penna a sfera



A

25 x 32 mm

1557
Mechanical pencil
Porte-mine
Portaminas
Bleistift
Portamine



B

30 x 5 mm

1558 Chrome
Ballpen
Bille
Bolígrafo
Kugelschreiber
Penna a sfera

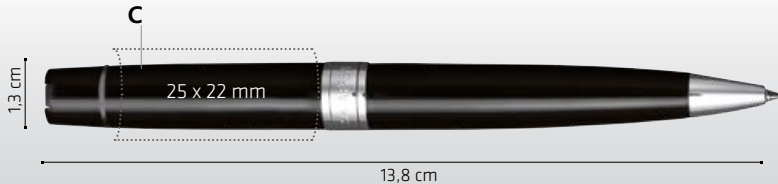

C

25 x 22 mm

13,8 cm



A> SP: max. 1 colour
B> LE: right, left & rear clip
C> SP: max. 1 colour
(Only for 1556 & 1557)

Finishes



Gloss Black /
Chrome Plate trim

Ø 0,7 mm



Gloss Blue /
Chrome Plate trim

NEW COLOUR



Metallic Grey /
Chrome Plate trim

NEW COLOUR

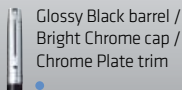

Glossy Black barrel /
Bright Chrome cap /
Chrome Plate trim



MOQ: 25 u.



Ø 0,7mm

± 2,9 Kg

Standard Packaging: Sheaffer® Luxury Gift Box (pg 221)
Optional Packaging: pg 221



SHEAFFER®
Sheaffer® 500

EN > **A beautifully styled**, finely balanced instrument that provides a smooth, comfortable writing experience.
New colours available.
Sheaffer® Limited **1 Year Warranty**.

FR > Instrument **magnifiquement stylé**, bien équilibré, offrant une expérience d'écriture confortable et fluide.
Nouvelles couleurs disponibles.
Garantie limitée Sheaffer® **de 1 an**.

ES > Bolígrafo de **estiloso diseño** y bien equilibrado que ofrece una escritura cómoda y suave.
Nuevos colores disponibles.
Garantía Sheaffer® **de 1 año**.

DE > Kugelschreiber im **modernen Design** für komfortables, weiches Schreiberlebnis.
Neue Farben erhältlich.
1-Jahr limitierte Sheaffer®-**Garantie**.

IT > **Penna a sfera** dal **design elegante**, ben equilibrata e con scrittura comoda e fluida. **Nuovi colori** disponibili.
1 anno di garanzia Sheaffer®.



NEW COLOUR

NEW COLOUR

1548
Ballpen
Bille
Bolígrafo
Kugelschreiber
Penna a sfera

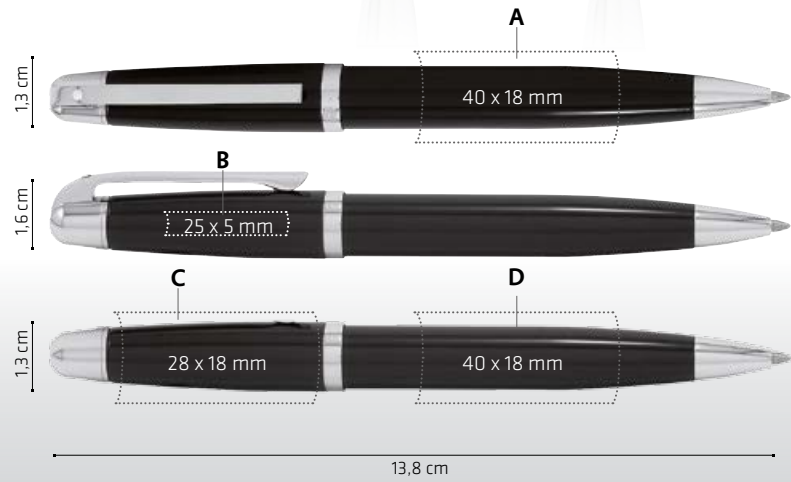

A / C / D > SP: max. 1 colour
B > LE: right, left & rear clip

Finishes

- 
Bright Chrome /
Chrome Plate trim
- 
Glossy Black /
Chrome Plate trim
- 
Glossy Dark Blue /
Chrome Plate trim
- 
Translucent Blue /
Chrome Cap /
Nickel Plate trim
NEW COLOUR
- 
Translucent Red /
Chrome Cap /
Nickel Plate trim
NEW COLOUR

MOQ: 25 u.



± 2.5 Kg

Standard Packaging: Sheaffer® Luxury Gift Box (pg 221)
Optional Packaging: pg 221

SHEAFFER® STYLUS COLLECTION

EN > The choice for a seamless transition between capacitive touchscreen devices and paper. **The choice for a smart dual experience.** Comfortable design with textured resin grip. Sheaffer® Limited **1 Year Warranty.**

FR > Le bon choix pour une transition en douceur entre les dispositifs avec écran tactile et le papier. **Le bon choix pour une double expérience toute en élégance/pleine d'élégance.** Forme confortable avec grip texturé. **Garantie Sheaffer® de 1 an.**

ES > La elección para una fluida transición entre los dispositivos con pantalla capacitiva y el papel. **La elección para una elegante experiencia dual.** Diseño cómodo con grip texturado. **Garantía Sheaffer® de 1 año.**

DE > Die Entscheidung für einen nahtlosen Übergang zwischen Geräten mit kapazitivem Touchscreen und Papier. **Eine elegante duale Erfahrung.** Komfortables Design mit strukturierter Griffzone. **1 Jahr** limitierte Sheaffer®-Garantie.

IT > La scelta elegante per conciliare la scrittura su carta e l'utilizzo di dispositivi con schermo touchscreen. Design confortevole con presa in resina ruvida. **Garanzia Sheaffer® di 1 anno.**

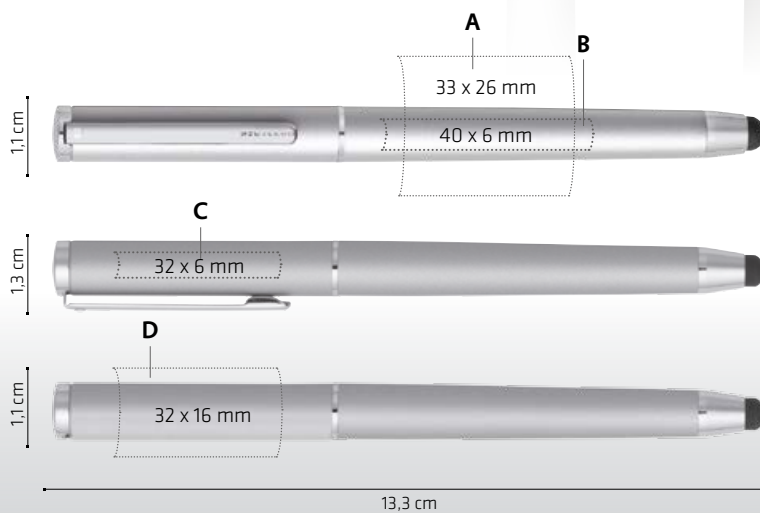

1453
Ballpen
Bille
Bolígrafo
Kugelschreiber
Penna a sfera



A / D > SP: max. 1 colour
B > LE
C > LE: right, left & rear clip

Finishes



MOQ: 25 u.



+ 2.5 Kg

Standard Packaging: Sheaffer® Standard Gift Box (pg 221)
Optional Packaging: pg 221



SHEAFFER
Sheaffer 100

EN > **The ideal gift for any occasion.** Modern design and attractive finishes. Sheaffer® Limited **1 Year Warranty.**

FR > **Le cadeau idéal en toute occasion.** Design moderne avec d'attrayantes finitions. **Garantie** limitée Sheaffer® de **1 an.**

ES > **El regalo ideal para cualquier ocasión.** Diseño moderno y acabados atractivos. **Garantía** Sheaffer® de **1 año.**

DE > **Das perfekte Geschenk für jede Gelegenheit.** Modernes Design in attraktiven Farbausführungen **1-Jahr** limitierte Sheaffer®-Garantie.

IT > **Il regalo perfetto per ogni occasione.** Design moderno e finiture attraenti. **1 anno di garanzia** Sheaffer®.



1546
Ballpen
Bille
Bolígrafo
Kugelschreiber
Penna a sfera

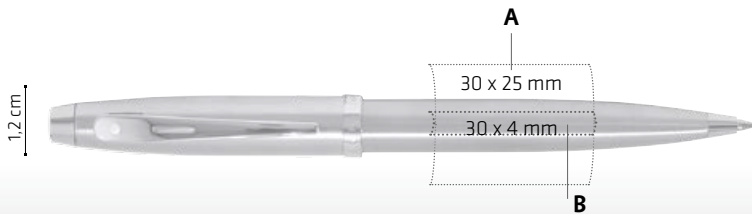

1547
Mechanical pencil
Porte-mine
Portaminas
Bleistift
Portamine



A> SP: max. 1 colour
B / C> LE

Finishes



Standard Packaging: Sheaffer® Standard Gift Box (pg 221)
Optional Packaging: pg 221



EN > Comfortable streamlined profile with **modern colour finishes**. Features Sheaffer® White Dot® symbol of quality. Sheaffer® Limited **1 Year Warranty**.

FR > Profil affiné et confortable avec des **finitions de couleur modernes**. Présente le symbole de qualité White Dot® Sheaffer®. **Garantie limitée Sheaffer® de 1 an**.

ES > Cómodo perfil aerodinámico con **acabados de colores actuales**. Con el símbolo de calidad Sheaffer® White Dot®. **Garantía Sheaffer® de 1 año**.

DE > Komfortables Stromliniendesign in **modernen Farbausführungen**. Mit dem Sheaffer® White Dot®, das Markenzeichen für Qualität. **1-Jahr limitierte Sheaffer®-Garantie**.

IT > Confortevole profilo aerodinamico con **finiture dai colori vivaci**. Con il puntino bianco Sheaffer® White Dot® simbolo di qualità. **1 anno di garanzia Sheaffer®**.

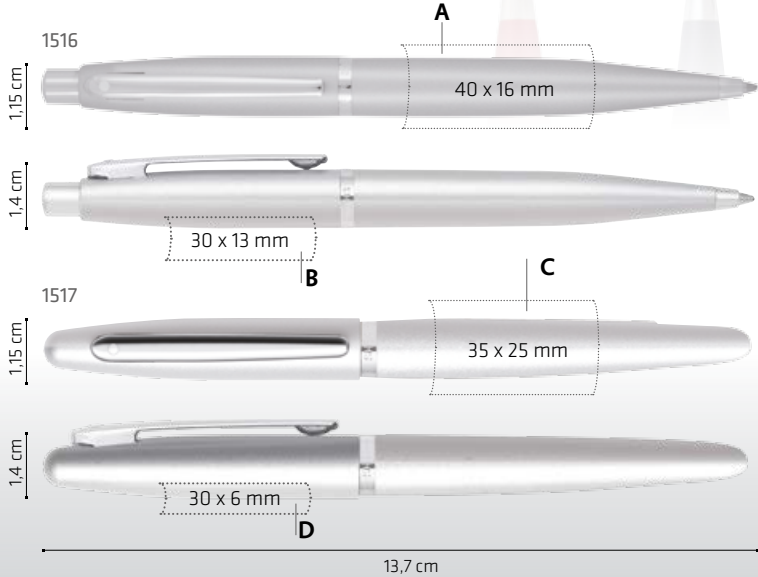

1516
Ballpen
Bille
Bolígrafo
Kugelschreiber
Penna a sfera

1517
Roller Ball
Stylo roller
Roller
Rollerball
Roller

A> SP: clip centred & rear clip. max. 2 colours
B/D > SP: max. 2 colours
C> SP: clip centred max. 1 colour

Finishes



Standard Packaging: Black velvet pouch for 1 item (pg 218)
Optional Packaging: pg 221

SHEAFFER.
Sentinel®

EN > **Slim profile**, classic styling.
Sheaffer® Limited
1 Year Warranty.

FR > **Profil mince**, style classique.
Garantie limitée Sheaffer®
de 1 an.

ES > **Perfil delgado** de diseño
clásico.
Garantía Sheaffer® **de 1 año.**

DE > **Schlankes Profil** im
klassischen Design.
1-Jahr limitierte Sheaffer®-
Garantie.

IT > **Profilo sottile** e stile classico.
1 anno di garanzia Sheaffer®.



1430
Ballpen
Bille
Bolígrafo
Kugelschreiber
Penna a sfera

1431
Mechanical pencil
Porte-mine
Portaminas
Bleistift
Portamine

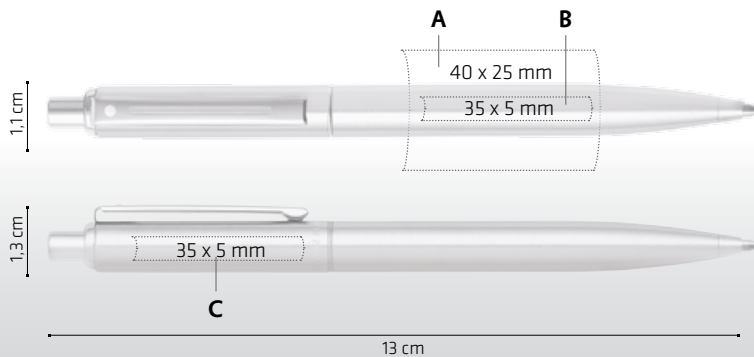

A> SP: max. 1 colour
B> LE
C> LE: right & left clip

Finishes



Standard Packaging: Black velvet pouch for 1 item (pg 218)
Optional Packaging: pg 221



SHEAFFER.
Sentinel®

EN > **Colourful slim profile** for ideal brand matching. **New colours** available. Sheaffer® Limited **1 Year Warranty.**

FR > **Profil fin aux couleurs vives**, idéal pour assortir avec votre marque. **Nouvelles couleurs** disponibles. **Garantie** limitée Sheaffer® **de 1 an.**

ES > **Perfil delgado de colores variados** ideal para combinar con tu marca. **Nuevos colores** disponibles. **Garantía** Sheaffer® **de 1 año.**

DE > **Farbenfrohes, schlankes Profil** für eine perfekte Abstimmung auf die Farben Ihrer Marke. **Neue Farben** erhältlich. Beschränkte Sheaffer® **-Garantie: 1 Jahr.**

IT > **Profilo sottile e colorato** per un abbinamento ideale al marchio. **Nuovi colori** disponibili. **1 anno di garanzia** Sheaffer®.



1436
Ballpen
Bille
Bolígrafo
Kugelschreiber
Penna a sfera

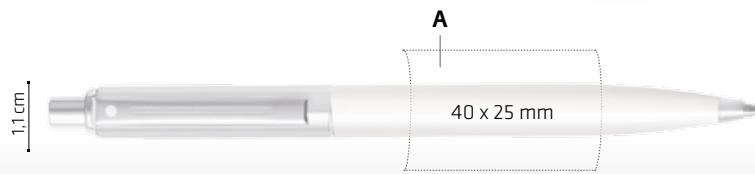

1437
Mechanical pencil
Porte-mine
Portaminas
Bleistift
Portamine

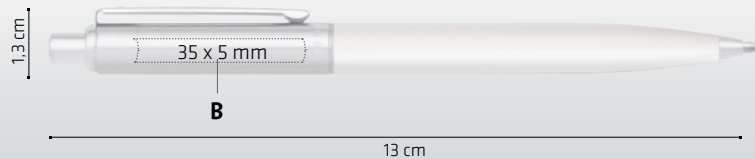

A> SP: max. 2 colours
B> LE: right & left clip

Finishes



Standard Packaging: Black velvet pouch for 1 item (pg 218)
Optional Packaging: pg 221

A world of possibilities from

SHEAFFER. standard catalogue*!

- ✓ NEW FINISHES
- ✓ ADDITIONAL WRITING MODES
- ✓ A WIDE RANGE OF COLOURS
- ✓ SAMPLES UPON REQUEST
- ✓ STOCK AVAILABILITY WITHIN 3 WEEKS



FR > Une infinité de possibilités dans le catalogue standard Sheaffer® !*

- ✓ NOUVELLES FINITIONS
- ✓ AUTRES MODES D'ÉCRITURE
- ✓ VASTE GAMME DE COULEURS
- ✓ ÉCHANTILLONS SUR DEMANDE
- ✓ STOCK DISPONIBLE EN 3 SEMAINES

Pour plus d'informations, contactez votre représentant du service clients.

* Sur demande

ES > ¡Un mundo de posibilidades en el catálogo estándar de Sheaffer® !*

- ✓ NUEVOS ACABADOS
- ✓ MODOS DE ESCRITURA ADICIONALES
- ✓ AMPLIA GAMA DE COLORES
- ✓ MUESTRAS BAJO PETICIÓN
- ✓ STOCK DISPONIBLE EN 3 SEMANAS

Para más información contacta con tu representante de atención al cliente.

* Bajo petición

DE > Eine Welt voller Möglichkeiten aus dem Sheaffer®-Standardkatalog!*

- ✓ NEUE AUSFÜHRUNGEN
- ✓ ZUSÄTZLICHE SCHREIBMODI
- ✓ BREITE FARBPALLETTE
- ✓ MUSTER AUF ANFRAGE
- ✓ LAGERARTIKEL INNERHALB VON 3 WOCHEN ERHÄLTICH

Kontaktieren Sie Ihren Kundendienst für weitere Informationen.

* Auf Anfrage

IT > Un universo di possibilità dal catalogo standard Sheaffer® !*

- ✓ NUOVE FINITURE
- ✓ NUOVE MODALITÀ DI SCRITTURA
- ✓ UN'AMPIA GAMMA DI COLORI
- ✓ CAMPIONI SU RICHIESTA
- ✓ DISPONIBILITÀ DI STOCK ENTRO 3 SETTIMANE

Per maggiori informazioni rivolgersi al proprio referente del Servizio Clienti.

* Su richiesta

Contact your customer service representative to get more information.

SHEAFFER.

Classic Mini Pad & Bi-Fold Wallet

14070

EN > Dual interior business card pockets, pen/USB loop, **custom Sheaffer® paper pad included**, custom Sheaffer® liner and rivet.

FR > Double poche intérieure pour cartes de visite, porte stylo/USB, **bloc de papier avec logo Sheaffer® inclus**, et **doublure et rivet avec logo Sheaffer® inclus**, doublure et rivet customisés Sheaffer®.

ES > Doble bolsillo interior para tarjetas de visita, sujeción para bolígrafo o USB, **bloc de notas Sheaffer® incluido**, forro interior y acabados Sheaffer®.

DE > Zwei Steckfächer für Visitenkarten, Schlaufe für ein Schreibgerät/USB, mit **Sheaffer®-Schreibblock**. **Hochwertiges Sheaffer®-Branding**: Außenniete und ins Innenfutter eingearbeitetes Logo.

IT > Doppia tasca interna per biglietti da visita, anello portapenna o chiavetta USB, **blocco note Sheaffer® incluso**, rivestimento interno e rifiniture con qualità Sheaffer®.

73066

EN > Three card slots, one I.D. window and two bill compartments. **Custom Sheaffer® Liner and exterior rivet.**

FR > Compartiment pour cartes de visite, compartiment transparent et deux compartiments pour billets. **Fermeture éclair personnalisée Sheaffer®, revêtement et rivet extérieur.**

ES > Tres compartimentos para tarjetas, un compartimento transparente para D.N.I y dos compartimentos para billetes. **Forro y remache exterior Custom Sheaffer®.**

DE > Drei Steckfächer für Karten, ein Fach für Personalausweis und zwei Geldschein-Fächer. **Hochwertiges Sheaffer®-Branding: Außenniete und ins Innenfutter eingearbeitetes Logo.**

IT > Tre alloggiamenti per tessere e carte di credito, finestrella e due scomparti per banconote. **Particolari e rivetti esterni personalizzati Sheaffer®.**

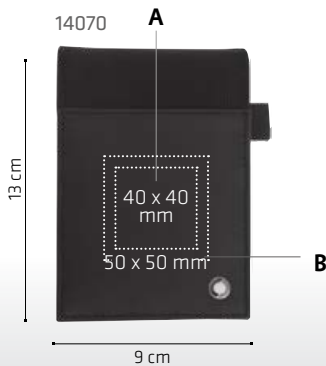

14070
Sheaffer® Classic
Mini Pad

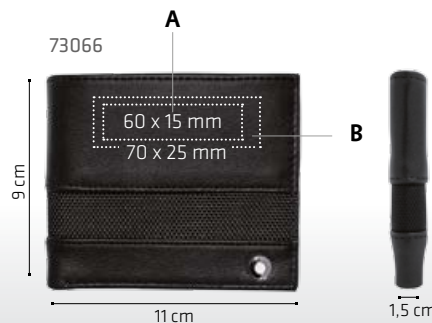

73066
Sheaffer® Classic
Bi-Fold Wallet



Finishes



100% leather and
1680D Polyester

Paper

14070
30 Sheets paper pad
Standard
90 g

14070 73066

MOQ: 10 U. 48 30
± 6,6 Kg ± 2,8 Kg

Standard Packaging: Gift boxes included on all Sheaffer® Padfolios and Accessories.

SHEAFFER.

Classic Junior Padfolio & Padfolio

EN > Zippered main compartment, interior organizing pockets for business cards and documents, pen/USB loop, **custom Sheaffer® paper pad included**, custom Sheaffer® liner and rivet.

FR > Compartiment principal zippé, pochettes intérieures de rangement pour cartes de visite et documents, porte stylo/USB, **bloc de papier avec logo Sheaffer® inclus**, doublure et rivets customisés Sheaffer®.

ES > Compartimento principal con cremallera, bolsillos interiores organizadores para tarjetas de visita y documentos, sujeción para bolígrafo o USB, **bloc de notas Sheaffer® incluido**, forro interior y acabados Sheaffer®.

DE > Hauptfach mit Reißverschluss, Einsteckfächer für Dokumente, Reisepass, Schlaufe für Schreibgerät/USB, mehrere Steckfächer für Visitenkarten, inneres Steckfach. **Hochwertiges Sheaffer®-Branding:** Außenniete und ins Innenfutter eingearbeitetes Logo.

IT > Compartimento principale con chiusura lampo, tasche interne con organizer per bigliettini da visita e documenti, **anello portapenna**, grande tasca interna, rivestimento e rifiniture con qualità Sheaffer®.



14071



15%

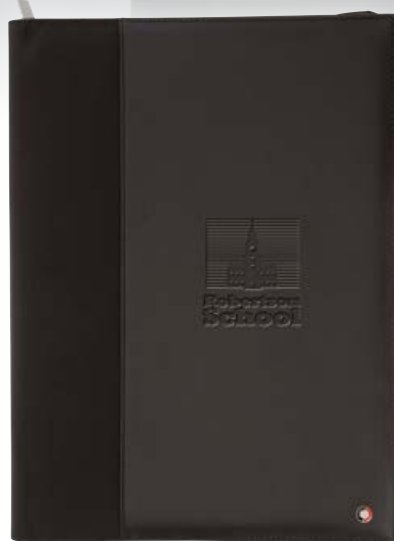

14072



15%

14071

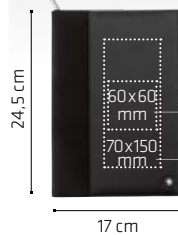

A
B



2 cm

14072

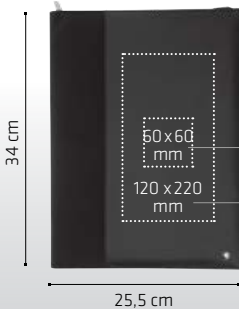

C
D



2,5 cm

A/C > DB
B/D > SP: max. 1 colour

14071



14072



14071
Sheaffer® Classic Junior
Padfolio

14072
Sheaffer® Classic Padfolio

Finishes



100% leather and
1680D Polyester

Paper

30 Sheets paper pad

Standard
90 g

14071 14072

MOQ: 10 u. 20 8
± 10 Kg ± 9 Kg

Standard Packaging: Gift boxes included on all Sheaffer® Padfolios and Accessories.

SHEAFFER.

Classic Tablet Holder

EN > Open main compartment, interior pockets for business cards and documents, **sleeve for tablet**, custom Sheaffer® rivet and liner.

FR > Compartiment principal ouvert, pochettes intérieures de rangement pour cartes de visite et documents, **pochette pour tablette**, doublure et rivets avec logo Sheaffer®.

ES > Compartimento principal abierto, bolsillos interiores para tarjetas de visita y documentos, **funda para Tablet PC**, forro interior y acabados Sheaffer®.

DE > Offenes Hauptfach, Einsteckfächer für Visitenkarten und Dokumente, **Hülle für Tablet-PC**, hochwertiges Sheaffer®-Branding: Außenniete und ins Innenfutter eingearbeitetes Logo.

IT > Compartimento principale aperto, tasche interne per biglietti da visita e documenti. **Custodia per tablet**. Rivestimento e rifiniture con qualità Sheaffer®.

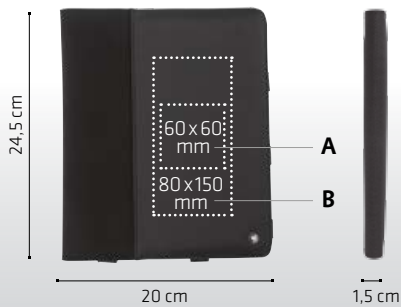

14073
Sheaffer® Classic Tablet
Holder

A> DB
B> SP: max. 1 colour



Finishes



100% leather and
ballistics nylon 1680D



MOQ: 10 u.



Standard Packaging: Gift boxes included on all Sheaffer® Padfolios and Accessories.

SHEAFFER.

Classic Travel Wallet

EN > Zippered closure on main compartment, interior **organizing pockets for tickets and passport**, pen loop, interior full-length slip pocket, multiple business card pockets, custom Sheaffer® rivet and liner.

FR > Compartiment principal zippé, pochettes intérieures de **rangement pour billets et passeport**, porte stylo, pochette arrière sur toute la longueur, multiples pochettes à cartes de visite, doublure et rivet avec logo Sheaffer®.

ES > Compartimento principal con cierre de cremallera, bolsillos interiores **organizadores para billetes y pasaporte**, sujeción para bolígrafo, gran bolsillo interior, múltiples bolsillos para tarjetas de visita, forro interior y acabados Sheaffer®.

DE > Hauptfach mit Reißverschluss, **Steckfächer für Dokumente, Reisepass**, Schreibgeräte-Schlaufe inneres Einsteckfach über die gesamte Größe, mehrere Fächer für Visitenkarten, hochwertiges Sheaffer®-Branding: Außenniete und ins Innenfutter eingearbeitetes Logo.

IT > Compartimento principale con chiusura lampo, **tasche interne per tickets e passaporto**, anello portapenna, grande tasca interna per bigliettini da visita, rivestimento e rifiniture con qualità Sheaffer®.



45%



25%

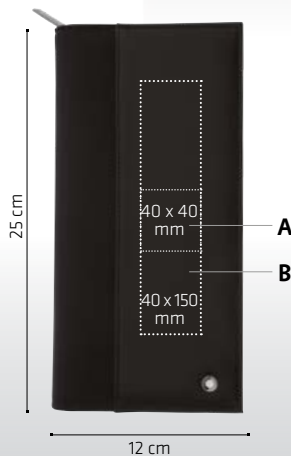

A> DB
B> SP: max. 1 colour



14074
Sheaffer® Classic Travel
Wallet

Finishes



100% leather and
1680D Polyester

MOQ: 10 u. 30
± 9.2 Kg

Standard Packaging: Gift boxes included on all Sheaffer® Padfolios and Accessories.

SHEAFFER

Classic Business Briefcase

EN > Sheaffer® Classic **Business Briefcase** with zipped main compartment, **padded sleeve for laptop**, front zipped pocket with organising pockets for business cards, pens and other accessories, second zipped compartment to hold documents and a removable and adjustable **Sheaffer® woven branded shoulder strap**. Custom Sheaffer® zipper pull, liner and exterior rivet. Black metal plate for engraving.

FR > Mallette Sheaffer® Classic **business briefcase** pourvue d'un compartiment principal avec fermeture à glissière, **d'une pochette matelassée pour ordinateur portable**, d'une poche frontale avec fermeture à glissière, de pochettes de rangement pour cartes de visite, stylos et autres accessoires, d'un compartiment secondaire avec fermeture à glissière pour documents et une sangle détachable et réglable. Logo Sheaffer® sur la languette de la fermeture à glissière, la doublure et le rivet extérieur. Plaque métallique noire pour gravure.

ES > **Maletín** Sheaffer® Classic **Business** con compartimento principal con cierre de cremallera, **compartimento acolchado para portátil**, bolsillo frontal con cierre de cremallera y bolsillos para tarjetas de visita, bolígrafos y otros accesorios; compartimento secundario para documentos y asa para llevar al hombro con tejido Sheaffer® ajustable y extraíble. Lleva la personalización Sheaffer® en el tirador de la cremallera, en el forro y en el ribete exterior. Placa metálica en color negro para la impresión láser.

DE > Sheaffer® Classic **Business Briefcase** Dokumententasche mit Hauptfach mit Reißverschluss, **gepolsterter Schutzhülle für Laptop**, Vordertasche mit Reißverschluss und Organizer-Taschen für Visitenkarten, Schreibgeräte und anderes Zubehör. Zweites Reißverschlussfach, um Dokumente unterzubringen und ein abnehmbarer, verstellbarer Sheaffer®-Woven-Schultertragegurt mit Branding. Hochwertiges Sheaffer®-Branding - Reißverschlusschieber, Futter und Außenniete. Schwarze Metallplakette für Gravur.

IT > Valigetta Sheaffer® Classic **business briefcase** con scomparto principale con chiusura lampo, **custodia imbottita per portatile**, tasca frontale con cerniera completa di tasche organizer per biglietti da visita, penne e altri accessori, secondo scomparto con chiusura lampo per contenere documenti e tracolla staccabile e regolabile in tessuto marchiata Sheaffer®. Tiralampo, fodera e borchia esterna personalizzati Sheaffer®. Piastrina metallica nera per incisioni



25%



Combine the Sheaffer® Classic Business Briefcase with a trolley! Find the Sheaffer® Classic 4 wheeled carry-on on page 142

25%

73062
Sheaffer® Classic Business Briefcase

A> LE: (Engraved metal plate available in black and silver colours)

Finishes



100% leather and 1680D Polyester

FR > Combinez la Mallette Sheaffer® Classic business briefcase avec une valise à roulettes ! Vous trouverez la valise 4 roues Sheaffer® Classic à la page 142

ES > ¡Combina el Maletín Sheaffer® Classic Business con un trolley! Encuentra la Maleta Sheaffer® Classic 4 ruedas en la página 142

DE > Kombinieren Sie die Sheaffer® Classic Business Briefcase Dokumententasche mit einem Trolley! Sie finden den Sheaffer® Classic 4-Rollen-Handkoffer auf Seite 142

IT > Abbina la Valigetta Sheaffer® Classic business briefcase a un trolley! Trovi il Trolley a 4 ruote Sheaffer® Classic a pagina 142



MOQ: 10 u.



+ 6.25 Kg

Standard Packaging: Individual polybag

SHEAFFER.

Classic Business Backpack

EN > Sheaffer® Classic Business Backpack with zippered main compartment with laptop sleeve. **Holds most 15" laptops.** Zippered compartment for documents and side mesh pockets. Front zippered pocket with interior organising pockets for business cards and pens, **padded shoulder strap and back** panel featuring an add-a-bag strap. Custom Sheaffer® zipper pull, liner and exterior rivet. Black metal plate for engraving.

FR > Sac à dos Sheaffer® Classic Business pourvu d'un compartiment principal avec fermeture éclair et d'une pochette pour ordinateur portable. **Apte pour la plupart des ordinateurs portables de 15"**. Compartiment avec fermeture éclair pour documents et poches filets latérales. Poche frontale avec fermeture éclair avec poches intérieures pour cartes de visite et stylos, **anses matelassées et anse dorsale** avec bretelle permettant d'ajouter un sac. Logo Sheaffer® sur le tirant de la fermeture éclair, la doublure et le rivet extérieur. Plaque métallique noire pour gravure.

ES > Mochila Sheaffer® Classic Business con compartimento principal con cierre de cremallera y compartimento para portátil. **Apta para la mayoría de portátiles de 15"**. Bolsillo frontal con cierre de cremallera, bolsillos interiores aptos para tarjetas de visita y bolígrafos, **asas acolchadas y asa dorsal** para poder adherirla a una maleta. Lleva la personalización Sheaffer® en el tirador de la cremallera y en el forro, y en el ribete exterior. Placa metálica en color negro para la impresión láser.

DE > Sheaffer® Classic Business-Rucksack mit Hauptfach und Reißverschluss sowie Laptopschutzhülle. **Passend für die meisten 15"-Laptops.** Fach mit Reißverschluss für Dokumente und Seitentaschen aus Mesh-Gewebe. Vordertasche mit Reißverschluss und Innentaschen zum Einordnen von Visitenkarten und Schreibgeräten, gepolsterter **Schultertragegurt und Rückenpanel mit Trageband** zum Anhängen an eine weitere Tasche. Hochwertiges Sheaffer®-Branding -Reißverschlussschieber, Innenfutter und Außenniete. Schwarze Metallplakette für Gravur.

IT > Zaino Sheaffer® Classic Business con scomparto principale a chiusura lampo con custodia per il portatile. **Adatto a quasi tutti i portatili di 15"**. Vano con chiusura lampo per i documenti e tasche laterali in rete. Tasca frontale con chiusura lampo, **tasche organizer interne per biglietti da visita e penne**, tracolla imbottita, e schienale dotato di cinghia add-a-bag. Tiralambo, fodera e borchia esterna personalizzati Sheaffer®. Piastrina metallica nera per incisioni.



25%



Combine the Sheaffer® Classic Business Backpack with a trolley! Find the Sheaffer® Classic 4 wheeled carry-on on page 142



A> LE: (Engraved metal plate available in black and silver colours)

73068
Sheaffer® Classic Business
Backpack

Finishes



100% leather and
1680D Polyester

FR > Combinez la Sac à dos Sheaffer® Classic Business avec une valise à roulettes ! Vous trouverez la valise 4 roues Sheaffer® Classic à la page 142

ES > ¡Combina la Mochila Sheaffer® Classic Business con un trolley! Encuentra la Maleta Sheaffer® Classic 4 ruedas en la página 142

DE > Kombinieren Sie die Sheaffer® Classic Business-Rucksack mit einem Trolley! Sie finden den Sheaffer® Classic 4-Rollen-Handkoffer auf Seite 142

IT > Abbinare lo Zaino Sheaffer® Classic Business a un trolley! Trovi il Trolley a 4 ruote Sheaffer® Classic a pagina 142



MOQ: 10 U.



± 5 Kg

Standard Packaging: Individual polybag

SHEAFFER

Travel Briefcase

NEW

EN > **Specially designed for short business trips.** Large main compartment **with cross elastic straps to hold your clothes.** Back compartment with padded laptop sleeve and front pocket with organiser panel and mesh pocket to hold your small devices. Back band to fit it on your trolley.

FR > **Spécialement conçue pour les voyages d'affaires.** Grand compartiment principal avec **bandes élastiques croisées pour tenir les vêtements.** Compartiment dorsal avec étui rembourré pour portable, poche avant avec compartiment organisateur et poche en maille pour petits dispositifs. compartiment de rangement permettant l'insertion de la sacoche sur un trolley.

ES > **Especialmente diseñada para viajes de negocios.** Gran compartimento principal con **bandas elásticas cruzadas para sostener la ropa.** Compartimento dorsal con funda acolchada para portátil y bolsillo frontal con panel organizador y bolsillo de malla para dispositivos pequeños. Banda dorsal para adherirla en un trolley.

DE > **Speziell für kurze Geschäftsreisen entworfen.** Geräumiges Hauptfach mit **gekreuzten Elastikbändern, die Ihre Kleidung am richtigen Platz halten.** Rückseitiges Fach mit gepolsterter Laptop-Hülle und Fronttasche mit Organizer-Panel und Tasche aus Mesh-Gewebe, um Ihre kleineren Geräte zu verstauen. Mit Band auf der Rückseite zur Befestigung am Trolley.

IT > **Ideata appositamente per brevi viaggi di lavoro.** Ampio scomparto principale con **bande elastiche incrociate per tenere in ordine i tuoi vestiti.** Scomparto posteriore con tasca imbottita per portatile, tasca frontale con pannello organizer e tasca a rete per piccoli accessori. Fascia posteriore da agganciare al trolley.



25%



Combine the Sheaffer® Travel Briefcase with a trolley! Find the Sheaffer® Classic 4 wheeled carry-on on page 142

A > LE: (Engraved metal plate available in black and silver colours)

76047
Sheaffer® Travel Briefcase

Finishes



100% leather and
1680D Polyester

FR > Combinez la sacoche de voyage Sheaffer® avec une valise à roulettes ! Vous trouverez la valise 4 roues Sheaffer® Classic à la page 142

ES > ¡Combina el maletín de viaje Sheaffer® con un trolley! Encuentra la Maleta Sheaffer® Classic 4 ruedas en la página 142

DE > Kombinieren Sie die Sheaffer® Reise Aktentasche mit einem Trolley! Sie finden den Sheaffer® Classic 4-Rollen-Handkoffer auf Seite 142

IT > Abbina la valigetta da viaggio Sheaffer® a un trolley! Trovi il Trolley a 4 ruote Sheaffer® Classic a pagina 142



MOQ: 10 u.



5

± 6,25 Kg
Standard Packaging: Individual polybag

SHEAFFER.

Garment Bag

NEW

EN > **Stylish travel companion** that is crafted from durable polyester with **high-quality leather accents**. This slim garment bag has two short handles with reinforced double-snap handle for comfortable use as well as a detachable shoulder-length handle for easy carrying. A large back zipper with custom Sheaffer® puller access to a spacious interior garment section for **more than two suits**.

FR > **Votre meilleure alliée pour voyager**, pleine de chic, confectionnée en polyester extrêmement résistant rehaussé par des **touches de cuir haut de gamme**. Cette fine housse à costumes est dotée de deux courtes anses, renforcées par une sangle de fermeture à double bouton pression, et d'une bandoulière détachable pour un plus grand confort et une facilité de transport. La grande fermeture à glissière à l'arrière portant le logo Sheaffer® facilite le rangement et l'extraction des vêtements du vaste espace **intérieur qui peut contenir plus de deux costumes**.

ES > **Estiloso compañero de viaje** hecho con resistente poliéster con **detalles de piel de alta calidad**. Este fino portatrajes tiene dos asas cortas reforzadas con un mango de doble broche para un uso más cómodo, así como una tira desmontable de hombro para que sea fácil de transportar. Una larga cremallera trasera con detalle Sheaffer® muestra un **amplio interior con lugar para dos trajes**.

DE > **Eleganter Reisebegleiter**, der aus strapazierfähigem Polyester mit hochwertigen **Leder-Akzenten hergestellt ist**. Dieser schmale Kleidersack hat zwei kurze Henkel mit verstärktem Tragegriff mit Doppel-Druckknopf für komfortables Handling und einen abnehmbaren, Schultertragegurt für bequemes Tragen. Ein großer Reißverschluss auf der Rückseite mit einem individuellen Sheaffer®-Reißverschlusschieber ermöglicht Zugang in das geräumige Kleiderinnenfach, **in das mehr als zwei Anzüge passen**.

IT > **Elegante accessorio da viaggio** realizzato in resistente poliestere con dettagli in **pelle di ottima qualità**. Questa sottile custodia per abiti è dotata di due corti manici fissabili insieme con un rinforzo a bottoni a pressione per un comodo utilizzo, oltre a una tracolla rimovibile per un facile trasporto. Un'ampia cerniera posteriore con tiralampe firmato Sheaffer® apre una sezione **interna sufficientemente spaziosa per contenere più di due abiti**.



20%

SHEAFFER®

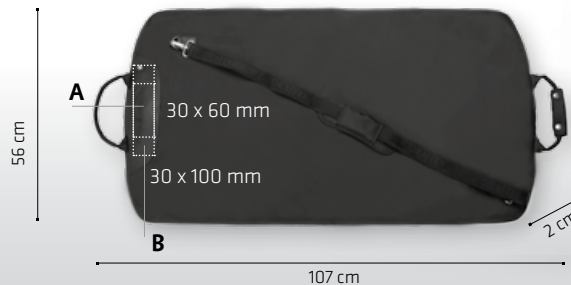

A > DB
B > SP: max. 1 colour

45078
Sheaffer® Garment bag

Finishes



100% leather and
1680D Polyester



MOQ: 10 U.



20
± 10 Kg

Sheaffer® Non-woven bag

SHEAFFER

Classic

4 wheeled carry-on

EN > Sheaffer® Classic **4-wheeled carry-on** with telescoping aluminium handle that extends to 100cm and features a comfortable grip. Main zippered compartment with inside zippered mesh organisation. Front zippered pocket and **two carry handles (top and side)**. **Four inline spinner wheels** with corner protectors allow for movement in any direction. Custom Sheaffer® zipper pull, liner and exterior rivet. Black metal plate.

FR > Cette valise dispose d'un manche en aluminium extensible de 100 cm et d'une poignée Confortable. Elle dispose d'un compartiment principal avec fermeture éclair incluant une poche filet avec fermeture éclair. Une autre poche avant avec fermeture éclair et **deux anses afin de pouvoir transporter la mallette (sur le dessus et les cotés)**. **Quatre roues en ligne** avec une protection sur les côtés qui permettent un mouvement facile dans n'importe quelle direction. Autorisée en transport aérien cabine.

ES > Maleta Sheaffer® Classic **4 ruedas de 53 cm** con un mango de aluminio extensible a 100 cm y con una confortable empuñadura. Compartimento principal con cremallera que dentro lleva una malla con cremallera. Un bolsillo con cremallera en la parte delantera y **dos mangos para llevar la maleta (en la parte de arriba y en una cara o lado)**. **Cuatro ruedas en línea** con protección en las esquinas permiten movimiento en cualquier dirección. Cumple con los requisitos de equipaje de mano: tirador de cremallera forro y ribete exterior.

DE > Sheaffer® Classic **4-Rollen-Handkoffer** mit komfortablem Aluminium-Teleskophandgriff, der bis zu 100 cm ausziehbar ist. Hauptfach mit Reißverschluss und einem innen mit Reißverschluss ausgestatteten Organisier aus Mesh-Gewebe. Vordere Reißverschluss tasche. Tragegriffe oben und seitlich. **Vier freischwenkende Räder mit Kantenschutz ermöglichen** Bewegung in jede beliebige Richtung. Hochwertiges Sheaffer®-Branding: Reißverschlusschieber, ins Innenfutter eingearbeitetes Logo, Außenniete. Schwarze Metallplatte.

IT > Elegante trolley Sheaffer® a **4 ruote sterzanti**, manico in alluminio telescopico da 100 cm con grip confortevole. Comparto principale con chiusura a cerniera e tasca interna a rete con chiusura lampo. Tasca anteriore con chiusura lampo e **2 maniglie (superiore e laterale)**. **Le quattro ruote con paracolpi** permettono il movimento in qualsiasi direzione. Soddisfa i requisiti per il trasporto come bagaglio a mano. Tiralampe, rivetti e particolari personalizzati Sheaffer®. Placchetta in metallo nero.



Combine this trolley with a briefcase!
Find the Sheaffer® Classic Business Briefcase on page 138

A> LE: (Engraved metal plate available in black and silver colours)

73067
Sheaffer® Classic 4 wheeled carry-on

Finishes



100% leather and 1680D Polyester

FR > Combinez cette valise 4 roues Sheaffer® Classic avec une mallette ! Vous trouverez la mallette d'affaires Sheaffer® Classic à la page 138

ES > Combina este trolley con un maletín! Encuentra el Maletín Classic Business Sheaffer® en la página 138

DE > Kombinieren Sie diesen Trolley mit einer Brieftasche! Sie finden die Sheaffer® Classic Reisebrieftasche auf Seite 138

IT > Abbina questo trolley a una valigetta! Trovi la Valigetta Sheaffer® Classic Business a pagina 138



MOQ: 10 U.

2

+ 9,108 Kg

Standard Packaging: Individual polybag

SHEAFFER.

Classic Business weekender

NEW

EN > Sheaffer® Classic **2-wheeled carry on** with telescoping aluminium handle that extends to 100 cm and features a comfortable grip. Front zipped pocket includes organiser panel and mesh pocket. **Front compartment for laptop quick access** and spacious main compartment with elastic straps. Comfortable top carry handle. Custom Sheaffer® zipper pull, liner and exterior rivet. Black metal plate.

FR > Mallette Sheaffer® Classic à **2 roues avec poignée** télescopique en aluminium qui s'allonge jusqu'à 100 cm et permet une bonne prise en main. La poche frontale avec fermeture à glissière contient un panneau de rangement et une pochette en filet de maille. **Compartment avant pour ordinateur portable à portée de la main** et compartiment principal spacieux avec sangles élastiques. Poignée supérieure pour faciliter le transport. Logo Sheaffer® sur la tirette de fermeture, la doublure et le rivet extérieur. Plaque métallique noire.

ES > **Equipaje de mano de dos ruedas** Sheaffer® Classic, con mango telescópico de aluminio que se extiende hasta 100 cm y que cuenta con un cómodo grip. Bolsillo frontal con cremallera que incluye un panel organizador y una bolsillo de malla. **Compartimento frontal de fácil acceso para ordenador** y amplio espacio principal con tiras elásticas. Cómoda asa superior. Cremallera, forro y remache exterior con acabados de Sheaffer®. Placa negra metálica.

DE > Sheaffer® Classic **Tasche mit 2 Rädern**. Teleskopstiel aus Aluminium mit komfortablem Griff, der bis zu 100cm ausziehbar ist. Die mit einem Reißverschluss versehene Vordertasche beinhaltet ein Organizer-Panel und eine Tasche aus Mesh-Gewebe. **Vorderfach, um schnell an den Laptop zu gelangen** und ein großes Hauptfach mit elastischen Riemen. Bequemer Tragegriff an der Oberseite. Hochwertiges Sheaffer®-Branding: Reißverschlusschieber, ins Innenfutter eingearbeitetes Logo, Außenniete. Schwarze Metallplatte.

IT > Sheaffer® Classic, **dotato di 2 ruote** e manico telescopico in alluminio allungabile fino a 100 cm. Le tasche frontali con chiusura lampo comprendono un pannello organizer e una tasca a rete. **Scomparto frontale per un facile accesso al portatile** e scomparto principale spazioso con fasce elastiche. Comodo manico superiore. Tiralampe, fodera e borchia esterna personalizzati Sheaffer®. Piastra di metallo nera.



25%



Combine this trolley with a Backpack!
Find the Sheaffer® Classic Business Backpack on page 139

A> LE: (Engraved metal plate available in black and silver colours)

45079
Sheaffer® Classic Business weekender

Finishes



100% leather and 1680D Polyester

FR > Combinez cette mallette de week-end Sheaffer® Classic avec un sac à dos! Vous trouverez le Sheaffer® Classic Business à la page 139

ES > Combina este trolley con una mochila! Encuentra la Mochila Sheaffer® Classic business en la página 139

DE > Kombinieren Sie diesen Trolley mit einem Rucksack! Sie finden den Sheaffer® Classic Businessrucksack auf Seite 139

IT > Abbina questo trolley a uno zaino! Trovi lo Zaino Sheaffer® Classic Business a pagina 139



MOQ: 10 u.



+ 5,5 Kg

Standard Packaging: Individual polybag



Adhesive Notepads

BIC® 50 mm x 75 mm Adhesive Notepads	146
BIC® 68 mm x 75 mm Adhesive Notepads	147
BIC® 75 mm x 75 mm Adhesive Notepads	148
BIC® 75 mm x 75 mm Adhesive Die Cut Notepads	149
BIC® 101 mm x 75 mm Adhesive Notepads	150
BIC® 101 mm x 75 mm Alternating Sheet Imprint	152
BIC® 101 mm x 75 mm Adhesive Die Cut Notepads	153
BIC® 101 mm x 101 mm Adhesive Notepads	154
BIC® 101 mm x 152 mm Adhesive Notepads	155

Booklets

BIC® 75 mm x 75 mm Adhesive Notepad with Flag Booklet	160
BIC® 75 mm x 75 mm Booklet	158
BIC® 101 mm x 75 mm Booklet	159
BIC® 101 mm x 75 mm Mini Pencil Booklet	161
BIC® 150 mm x 150 mm Booklet Organiser	164
BIC® 150 mm x 150 mm Booklet with Pen Loop	165
BIC® Clic Stic Mini Organiser	162
BIC® Digital Clic Stic Mini Organiser	163
BIC® Flag Booklet	157

Scratch Pad

BIC® 75 mm x 127 mm Non-Adhesive Scratch Pad	166
BIC® 96 mm x 152 mm Non-Adhesive Scratch Pad	167

Call home!



BIC® 101 mm x 75 mm Alternating Sheet Imprint

Meeting at
10:00 a.m.



All rights reserved. © 2011 Inspire Structure. All rights reserved.

Lunch at
13:00h



© 2011 ironshake



50 mm x 75 mm Adhesive Notepads

EN > Ideal **pocket size** for mailing campaigns!

FR > **Taille de poche** idéale pour les notes d'entreprise !

ES > **¡Tamaño de bolsillo** ideal para notas de empresa!

DE > Ideales **Taschenformat** für Mailingkampagnen!

IT > **Dimensioni tascabili** ideali per appunti di lavoro!



100%

BIC® STICKY NOTE™

3522 / 3520
25

3552 / 3550
50

3582 / 3580
100

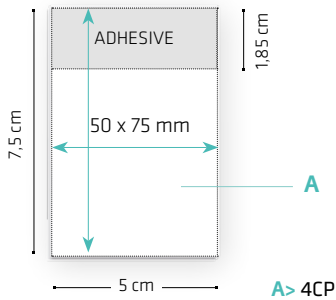

Paper type

Standard
80 g

Recycled
80 g



MOQ: 500 u.

3522 / 3520
1000
± 8.7 Kg

3552 / 3550
500
± 8.5 Kg

3582 / 3580
250
± 8.4 Kg

BIC eSolutions
Recycled Content
Option pg 195





68 mm x 75 mm Adhesive Notepads

- EN > Sticky Note™ pad ideal to take your messages always with you!
- FR > Bloc-notes Sticky Note™ idéal pour porter vos messages toujours sur vous !
- ES > Bloc de notas Sticky Note™ ¡ideal para llevar tus mensajes siempre contigo!
- DE > Sticky Note™-Notizblock: Ideal, um Ihre Nachrichten immer bei sich zu tragen!
- IT > Blocchetto Sticky Note™ ideale per portare i tuoi messaggi sempre con te!



100%

BIC® STICKY NOTE™

3502 / 3500
25

3532 / 3530
50

3562 / 3560
100

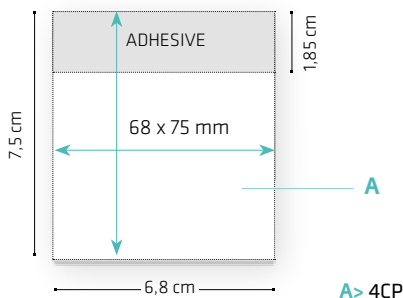

Paper type

- Standard 80 g
- Recycled 80 g

 4CP	MOQ: 500 u.	3502 / 3500	3532 / 3530	3562 / 3560
		500	250	130
		± 5.7 Kg	± 5.4 Kg	± 5.6 Kg

BIC eSolutions
Recycled Content
Option pg 195





75 mm x 75 mm Adhesive Notepads

- EN > **Large imprint area in a small size!**
- FR > **Grande zone d'impression avec une taille mini !**
- ES > **¡Gran área de impresión en tamaño pequeño!**
- DE > **Großer Druckbereich, kleines Format!**
- IT > **Vasta area di stampa in piccolo formato!**



100%



BIC® STICKY NOTE™

3507 / 3505

25

3537* / 3535

50

3567 / 3565

100

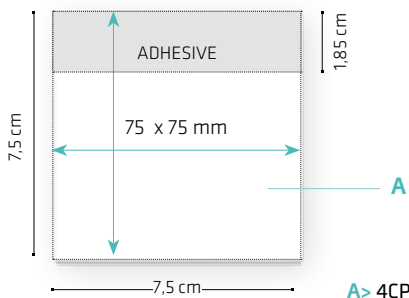

Paper type

- Standard 80 g
- Recycled 80 g



MOQ: 500 u.

3507 / 3505
500
± 6,2 Kg

3537* / 3535
250
± 5,9 Kg

3567 / 3565
130
± 6,1 Kg

BIC eSolutions
Recycled Content
Option pg 195





75 mm x 75 mm Adhesive Die Cut Notepads

EN > Choose from **7 stock shapes!**
Custom-made shapes also **available** upon request

FR > Choisissez parmi les **7 formes en stock!**
Formes spéciales sur demande.

ES > ¡Escoja entre **7 formas diferentes!**
Formas personalizadas también **disponibles** bajo petición.

DE > Wählen Sie eine der **7 Standardformen.**
Kundenspezifische Formen sind auf Anfrage **erhältlich.**

IT > Scegli tra le **7 forme disponibili!**
Forme personalizzate **disponibili** su richiesta.



BIC® STICKY NOTE™

3603 / 3601
25

3607 / 3605
50

3611 / 3609
100

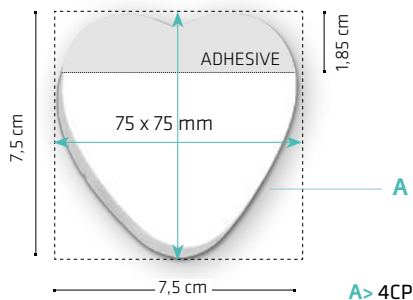

A > 4CP

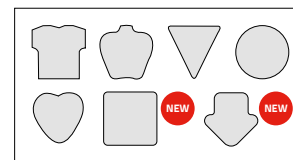

Paper type

Standard
80 g

Recycled
80 g



MOQ: 500 u.

3603 / 3601
500
± 6.2 Kg

3607 / 3605
250
± 6 Kg

3611 / 3609
130
± 6.2 Kg

BIC eSolutions
Recycled Content
Option pg 195





101 mm x 75 mm
Adhesive Notepads



BIC® STICKY NOTE™

EN > **Indispensable** in any office.
Most popular Sticky Note™ pad **size!**





101 mm x 75 mm

Adhesive Notepads

FR > **Indispensable** dans n'importe quel bureau. Le Sticky Note™ de la taille la plus populaire !

ES > **Indispensable** en cualquier oficina. ¡El **bloc de notas** Sticky Note™ del tamaño más popular!

DE > **Unverzichtbar** in jedem Büro. Die **beliebteste** Sticky Note™-Notizblockgröße!

IT > **Indispensabile** in ogni ufficio. Lo Sticky Note™ nel formato più diffuso!



BIC® STICKY NOTE™

100%

3512 / 3510
25

3542* / 3540
50

3572 / 3570
100

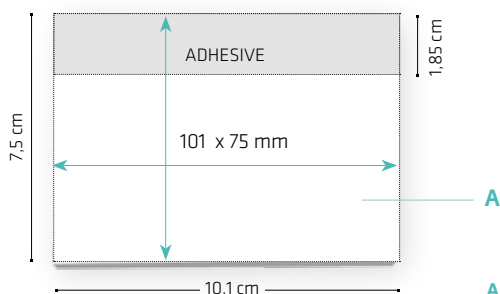

A > 4CP

Paper type



Product Code	MOQ	Weight
3512 / 3510	500 u.	± 8.2 Kg
3572 / 3570	130	± 8.3 Kg
3542* / 3540	250 u.	± 8 Kg





101 mm x 75 mm Alternating Sheet Imprint

EN > Great marketing tool!
Alternate 2 messages
for double-impact
communication!

FR > Un très bon outil de
marketing!
Alternez 2 messages
pour un double impact !

ES > ¡Gran herramienta de
marketing! **¡Alterna 2
mensajes** para obtener
un doble impacto!

DE > Großartiges
Marketinginstrument!
**Mit zwei sich Seite-für-
Seite abwechselnden**
Botschaften erzielen Sie
die doppelte Wirkung!

IT > Grande strumento di
marketing! **Alterna 2
messaggi** per ottenere
un doppio impatto!



BIC® STICKY NOTE™

3514 / 3513
25

3544 / 3543
50

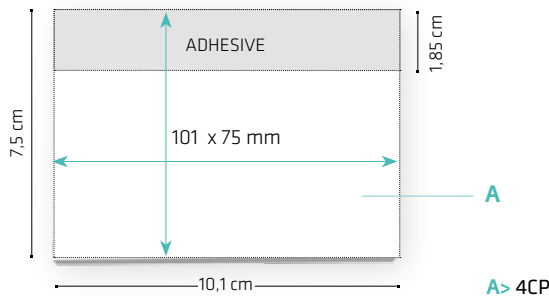

Paper type

Standard 80 g
Recycled 80 g

* We cannot guarantee that the first sheet of the pad is always the same image
* Nous ne pouvons garantir que la première feuille du pad porte toujours la même image
* No podemos garantizar que la primera hoja del pad sea siempre la misma imagen
* Wir können nicht garantieren, dass die erste Seite jedes Blocks immer das gleiche Motiv zeigt
* Non possiamo garantire che la prima pagina abbia sempre la stessa immagine

4CP
MOQ: 500 u.

3514 / 3513
500
± 8.2 Kg

3544 / 3543
250
MOQ: 250 u.
± 8 Kg

BIC eSolutions
Recycled Content
Option pg 195

MADE IN SPAIN



101 mm x 75 mm Adhesive Die Cut Notepads

EN > Choose from **29 stock shapes!**
Custom-made shapes also available upon request.

FR > Choisissez parmi les **29 formes en stock !**
Formes spéciales sur demande.

ES > ¡Escoge entre **29 formas diferentes!**
Formas personalizadas también disponibles bajo petición.

DE > Wählen Sie eine der **29 Standardformen.**
Kundenspezifische Formen sind auf Anfrage erhältlich.

IT > Scegli tra le oltre **29 forme!**
Forme personalizzate disponibili su richiesta.



BIC® STICKY NOTE™

3604 / 3602
25

3608 / 3606
50

3612 / 3610
100

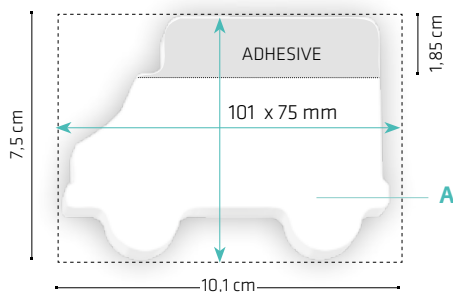

A > 4CP

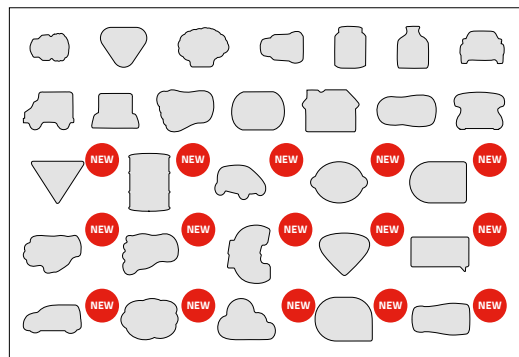

Paper type

Standard 80 g
Recycled 80 g



MOQ: 500 u.

3604 / 3602	3608 / 3606	3612 / 3610
400	200	100
± 6,6 Kg	± 6,4 Kg	± 6,4 Kg

BIC eSolutions
Recycled Content
Option pg 195





101 mm x 101 mm Adhesive Notepads

BIC® STICKY NOTE™

- EN > Stand out from the crowd with this **original square shape!**
- FR > Démarquez-vous des autres avec cette **originale forme carrée!**
- ES > ¡Destaca sobre los demás con esta **original forma cuadrada!**
- DE > Heben Sie sich von der Masse ab! Mit dieser **originellen quadratischen Form!**
- IT > Spicca tra tutti per la sua **originale forma quadrata!**



100%



70%

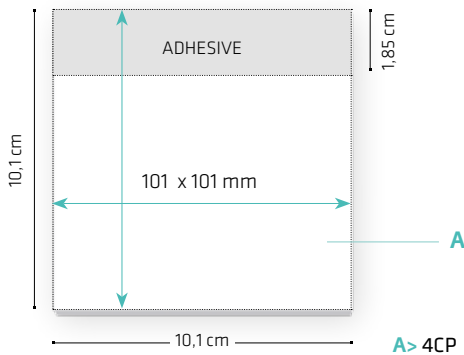

3518 / 3516
25

3548 / 3546
50

3578 / 3576
100

Paper type

- Standard 80 g
- Recycled 80 g



MOQ: 500 u.

3518 / 3516
400
± 9.5 Kg

3548 / 3546
200
± 9.1 Kg

3578 / 3576
100
± 8.7 Kg

BIC eColutions®
Recycled Content
Option pg 195





101 mm x 152 mm Adhesive Notepads

EN > **Large** imprint **area** for big messages. Don't miss anything!

FR > **Grande surface** d'impression pour de grands messages. Pour que rien ne vous échappe !

ES > **Gran área** de impresión para grandes mensajes. ¡No te olvides de nada!

DE > **Große Druckfläche** für großartige Nachrichten. Vergessen Sie nichts!

IT > **Ampia area** di stampa per grandi messaggi. Non perderti nulla!



BIC® STICKY NOTE™

90%

3517 / 3515
25

3547 / 3545
50

3577 / 3575
100

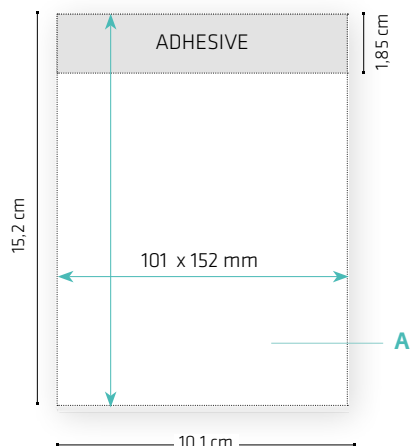

A > 4CP

Paper type

Standard
80 g

Recycled
80 g*



MOQ: 500 u.

3517 / 3515
250
± 8.5 Kg

3547 / 3545
125
± 8.2 Kg

3577 / 3575
65
± 8.3 Kg

BIC eSolutions
Recycled Content
Option pg 195





Sticky Note™ Booklets

EN > **Brilliant** laminated covers
to make **your brand shine!**



BIC® STICKY NOTE™



Flag Booklet

EN > The most desired office item!

Play with your logo in a vertical or horizontal position!

FR > Couvertures laminées brillantes

pour faire briller votre marque !
L'article de bureau le plus convoité ! Jouez avec votre logo en position verticale ou horizontale !

ES > ¡Cubierta laminada brillante

para hacer que **tu marca resplandezca!**
¡El elemento de oficina más deseado! ¡Juegue con su logo en posición vertical o horizontal!

DE > Glänzend laminierte

Deckseiten, die Ihre Marke zum Strahlen bringen!
Der begehrteste Büroartikel! Spielen Sie mit Ihrem Logo in vertikaler oder horizontaler Position!

IT > Copertine lucide

per **far brillare il tuo marchio!**
Il più desiderato in ufficio! Gioca con il tuo logo in posizione orizzontale o verticale!



100%

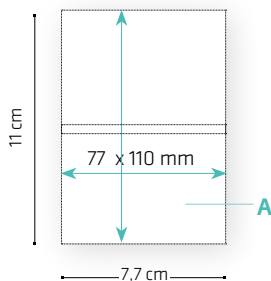

3730
25

A> 4CP

125 Mylar flags, 25 of each 5 colours
125 index repositionnables, 25 de chaque couleur
125 Mylar flags, 25 de cada 5 colores
125 Haftstreifen aus Polyesterfilm, je 25 in jeder der 5 Farben
125 segnapagina totali, 25 per colore



MOQ: 250 u.





75 mm x 75 mm Booklet

BIC® STICKY NOTE™

EN > **Double impact** of your message with a fully personalised cover and Sticky Note™ pad.

FR > **Double impact** de votre message grâce à la couverture personnalisée et au bloc-notes Sticky Note™.

ES > **Doble impacto** para su mensaje gracias a su cubierta personalizada y su bloc de notas Sticky Note™.

DE > **Doppelte Wirkung** für Ihre Marke dank vollständig personalisierter Deckseite und Sticky Note™-Notizblock.

IT > Un **doppio impatto** per il tuo messaggio con la copertina e il blocco Sticky Note™ personalizzati.



100%

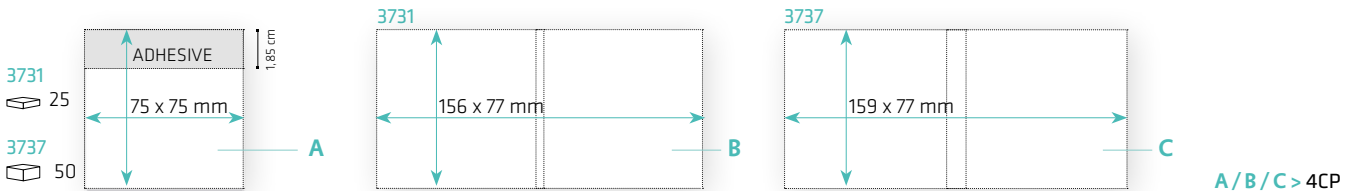

Paper type

Standard
80 g



MOQ: 250 u.
with
unimprinted
pad

MOQ: 500 u.
with
imprinted
pad

3731
500
+ 28 Kg

3737
250
+ 73 Kg





101 mm x 75 mm Booklet

EN > **Double impact** of your message with a fully personalised cover and Sticky Note™ pad in the most popular size.

FR > **Double impact** de votre message grâce à la couverture personnalisée et au bloc-notes Sticky Note™ dans sa taille la plus populaire.

ES > **Doble impacto** para su mensaje gracias a su cubierta personalizada y su bloc de notas Sticky Note™ en su tamaño más popular.

DE > **Doppelte Wirkung** für Ihre Marke dank vollständig personalisierter Deckseite und Sticky Note™-Notizblock im beliebtesten Format.

IT > Un **doppio impatto** per il tuo messaggio con la copertina e il blocco Sticky Note™, nel formato più diffuso, personalizzati.

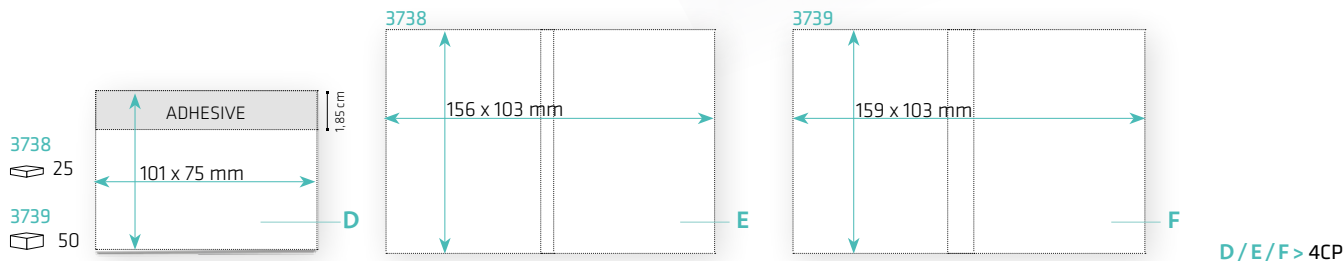

Paper type

Standard
80 g



MOQ: 250 u.
with unimprinted pad

MOQ: 500 u.
with imprinted pad

3738
500
+ 5,9 Kg

MOQ: 250 u.
with imprinted pad

3739
250
+ 5,1 Kg





75 mm x 75 mm

Adhesive Notepad with Flag Booklet

EN > The **multipurpose** notes tool.

FR > Le **multifonction** pour la prise de notes.

ES > ¡El bloc de notas **multiuso!**

DE > Das **Multitool** für Ihre Notizen.

IT > Il blocchetto **multi funzione!**



70%

BIC® STICKY NOTE™

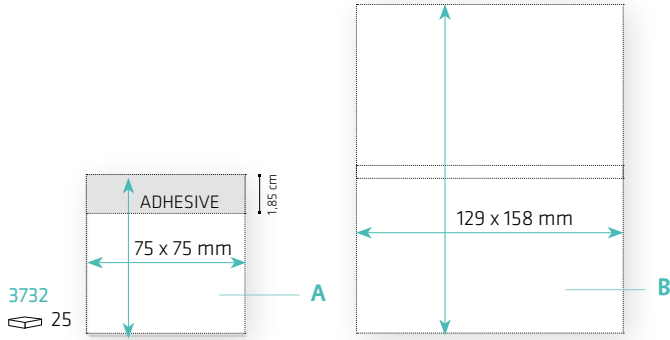

Paper type

Standard
80 g

125 Mylar flags, 25 of each 5 colours
125 index repositionnables, 25 de chaque couleur
125 Mylar flags, 25 de cada 5 colores
125 Haftstreifen aus Polyesterfilm, je 25 in jeder der 5 Farben
125 segnapagina totali, 25 per colore



4CP

MOQ: 250 u.
with
unimprinted
pad

MOQ: 500 u.
with
imprinted
pad

3732

200

+ 5.2 Kg





101 mm x 75 mm Mini Pencil Booklet

EN > This great office **set includes BIC® Matic Mini pencil.** Always ready to take your notes!

FR > Ce superbe **set de bureau comprend le porte-mine BIC® Matic Mini.** Toujours prêt pour prendre des notes !

ES > Este fantástico **set de oficina incluye el lápiz BIC® Matic Mini.** ¡Siempre a punto para tomar tus notas!

DE > Dieses tolle Büroset **beinhaltet den BIC® Matic Mini-Bleistift.** Allzeit bereit, Notizen zu machen!

IT > Questo fantastico **set per ufficio include il portamine BIC® Matic Mini.** Sempre pronto a prendere appunti!

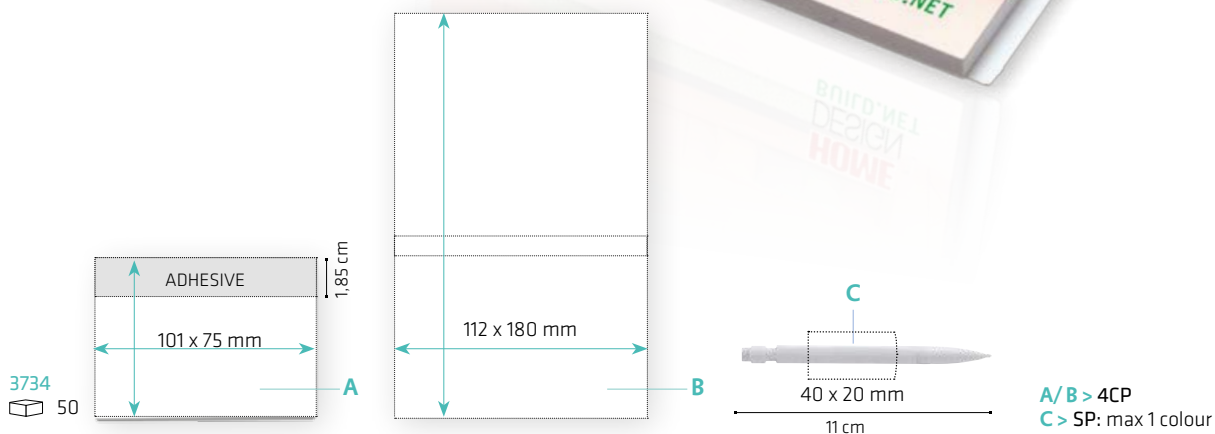

Paper type

Standard
80 g



MOQ: 250 u.

200
± 5.2 Kg





Clic Stic Mini Organiser

EN > Use this all-in-one organiser for meeting and daily notes. **Includes BIC® Clic Stic Mini pen.**

FR > Utilisez ce set de rangement tout en un pour vos réunions et vos notes quotidiennes. **Stylo BIC® Clic Stic Mini inclus.**

ES > Usa este organizador todo en uno para reuniones y notas de cada día. **Bolígrafo BIC® Clic Stic Mini incluido.**

DE > Verwenden Sie diesen All-in-One-Organizer für Meetings oder Ihre alltäglichen Notizen. **Beinhaltet den BIC® Clic Stic Mini-Kugelschreiber.**

IT > Utilizza questo organizer tutto in uno per riunioni e appunti quotidiani. **Include la penna BIC® Clic Stic Mini.**



60%

BIC® STICKY NOTE™

3733

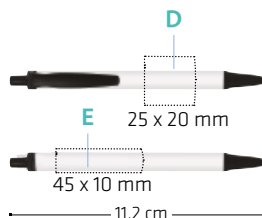
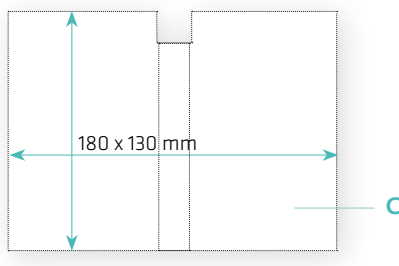
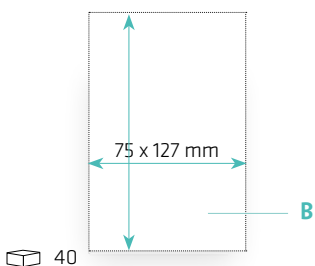
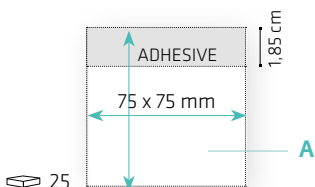

MIX & MATCH

BIC® Clic Stic Mini
Clip and Section

OPAQUE				FROSTED			BARREL
01	02	03	04	40	63	66	01
05	07	10	12	67	68	69	
18	20			71			

A/ B / C > 4CP
D / E > SP: max 1 colour

Paper type
Standard
80 g

Barrel
OPAQUE
01

125 Mylar flags, 25 of each 5 colours
125 index repositionnables, 25 de chaque couleur
125 Mylar flags, 25 de cada 5 colores
125 Haftstreifen aus Polyesterfilm, je 25 in jeder der 5 Farben
125 segnapagina totali, 25 per colore



MOQ: 250 u. with unimprinted pad
MOQ: 500 u. with imprinted pad

125
± 7 Kg





Digital Clic Stic Mini Organiser

- EN > **Photographic image all around!** This exceptional communication tool **includes BIC® Clic Stic Mini Digital pen.**
- FR > **Image photographique de toutes parts !** Cet article exceptionnel de communication **comprend un stylo BIC® Clic Stic Mini Digital.**
- ES > **¡Imagen fotográfica en todas partes!** Este excepcional artículo de comunicación **incluye el bolígrafo BIC® Clic Stic Mini Digital.**
- DE > **Photo-Image auf allen Seiten!** Dieses außergewöhnliche Kommunikations-Tool **beinhaltet den BIC® Clic Stic Mini-Digitalstift.**
- IT > **Immagine fotografica dappertutto!** Questo eccezionale strumento di comunicazione **include la penna BIC® Clic Stic Mini Digital.**



3735

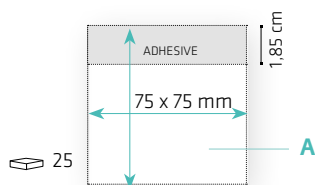

25

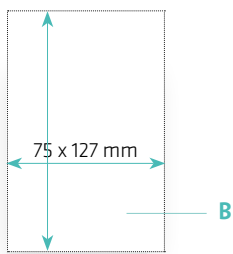

40

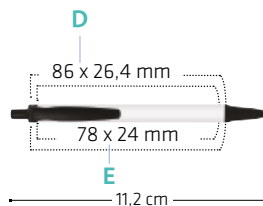
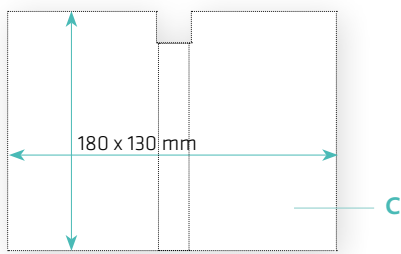

MIX & MATCH

BIC® Clic Stic Mini Digital
Clip and Section

OPAQUE				FROSTED			BARREL
01	02	03	04	40	63	66	01
05	07	10	12	67	68	69	
18	20			71			

A/B/C> 4CP

D/E> SP: max 1 colour

Paper type

Standard
80 g

Barrel

OPAQUE
01

125 Mylar flags, 25 of each 5 colours
125 index repositionnables, 25 de chaque couleur
125 Mylar flags, 25 de cada 5 colores
125 Haftstreifen aus Polyesterfilm, je 25 in jeder der 5 Farben
125 segnepagina totali, 25 per colore



4CP

MOQ: 250 u.
with
unimprinted
pad

MOQ: 500 u.
with
imprinted
pad

125
± 7 Kg



MADE IN
SPAIN



150 mm x 150 mm Booklet Organiser

EN > Create a unique note pad with this **original square shape!**

FR > Créez un carnet de notes unique avec une **forme originale !**

ES > ¡Crea una libreta única con una **original forma cuadrada!**

DE > Kreieren Sie einen einzigartigen Schreibblock in dieser **originellen quadratischen Form!**

IT > Crea un blocchetto unico con la sua **originale forma quadrata!**



40%

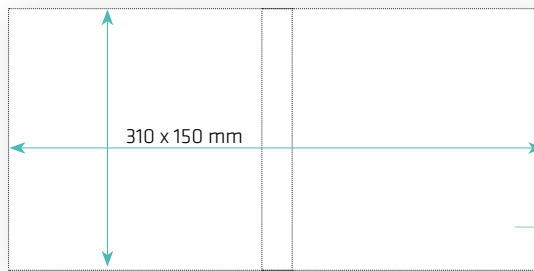
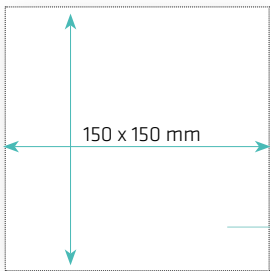

3745
100

A

B

A/B > 4CP

Paper type

Standard
80 g



MOQ: 500 u.

40
± 6,4 Kg





150 mm x 150 mm

Booklet with Pen Loop

EN > Make your notes stand out using this **original format**. Suggested presentation with BIC® Wide Body™ Digital. **Combine this item with any of our writing products.**

FR > Mettez vos notes en relief grâce à ce **format original**. Suggestion de présentation avec le BIC® Wide Body™ Digital. **Combinez cet article avec n'importe quel produit d'écriture.**

ES > Destaque sus notas con este **original formato**. Sugerencia de presentación con BIC® Wide Body™ Digital. **Combine este artículo con cualquiera de nuestros productos de escritura.**

DE > Heben Sie Ihre Notizen auf diesem neuen **originellen Format** hervor. Empfohlene Anwendung mit BIC® Wide Body™ Digital. **Kombinieren Sie diesen Artikel mit einem unserer Schreibgeräte.**

IT > Prendi i tuoi appunti utilizzando questo **formato originale**. **Abbina questo prodotto con uno dei nostri articoli da scrittura.** Prodotto consigliato. BIC® Wide Body™ Digital.



BIC® STICKY NOTE™

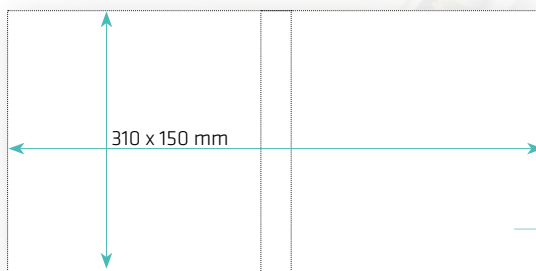
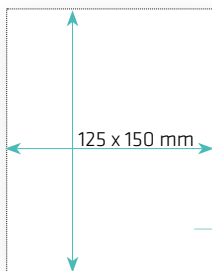

3746
100

A

B

A/ B > 4CP

Paper type



Standard
80 g

* Pen not included / Stylo non inclus / Bolígrafo no incluido / Ohne Kugelschreiber / Penna non inclusa.



MOQ: 500 u.



± 6.7 Kg



MADE IN SPAIN



75 mm x 127 mm Non-Adhesive Scratch Pad

BIC® STICKY NOTE™

EN > **Indispensable scratch pad** for lists and quick notes.

FR > **L'outil indispensable** pour vos notes et mémos.

ES > **Bloc de notas indispensable** para hacer listas y notas rápidas.

DE > **Unverzichtbarer Notizblock** für Listen und schnelle Notizen.

IT > **Blocco note indispensabile** per fare liste e prendere appunti veloci.



70%

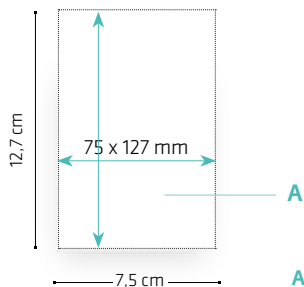

- 3760 20
- 3761 40

Paper type
 Standard
80 g



MOQ: 500 u.

3760 400 + 5.4 Kg
3761 200 + 5.2 Kg





96 mm x 152 mm Non-Adhesive Scratch Pad

EN > **Indispensable scratch pad** for lists and quick notes.

FR > **L'outil indispensable** pour vos notes et mémos.

ES > **Bloc de notas indispensable** para hacer listas y notas rápidas.

DE > **Unverzichtbarer Notizblock** für Listen und schnelle Notizen.

IT > **Blocco note indispensabile** per fare liste e prendere appunti veloci.

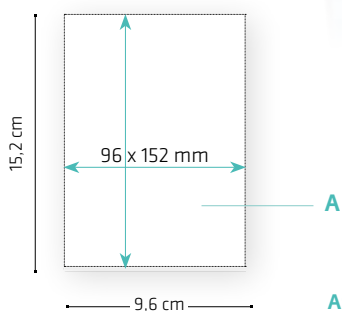

- 3762 20
- 3763 40

A > 4CP

Paper type

Standard
80 g



MOQ: 500 u.

3762 3763
400 200
+ 8,6 Kg + 8 Kg



BIC® STICKY NOTE™



Chipboard Cover Notebooks

BIC® Notebooks Chipboard Cover	174
BIC® Notebooks Chipboard Cover <i>britePix</i> ™	175

Plastic Cover Notebooks

BIC® Notebooks Plastic Cover	170
BIC® Notebooks Plastic Cover <i>britePix</i> ™	171
BIC® Notebooks Plastic Cover Fashion Colours	172
BIC® Notebooks Plastic Cover Fashion Colours <i>britePix</i> ™	173

friend,

pe we
soun

Regard

BIC® Notebooks Plastic Cover

- EN > **Transparent plastic cover** notebook with a **sturdy elastic loop** for any pen size.
- FR > Cahier à spirales avec **couverture plastique transparente** et **boucle élastique** adaptée à tous les types de stylos.
- ES > Cuaderno de **tapa plástica transparente** con **cinta elástica** para cualquier tamaño de bolígrafo.
- DE > Notizbuch **mit transparentem Kunststoffeinband** und **elastischer Schlaufe** für Kugelschreiber jeder Größe.
- IT > Quaderno con **copertina di plastica trasparente** con **portapenna elastico** per qualsiasi dimensione di penna.

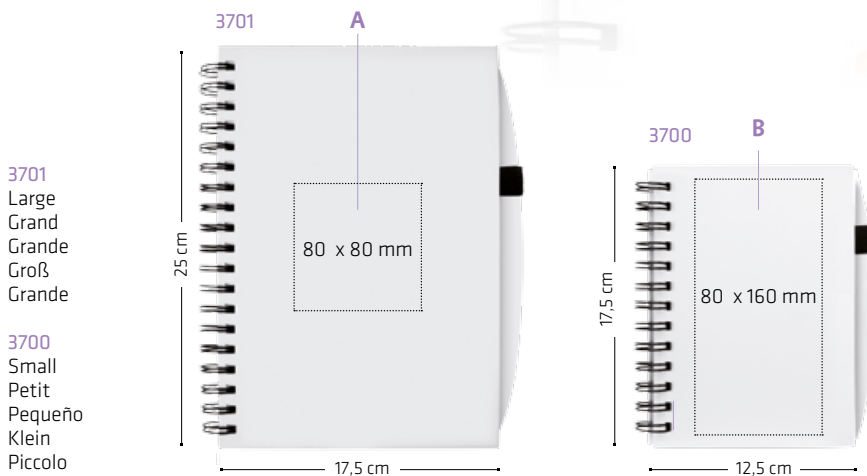

A> SP: max. 4 colours
B> SP: max. 4 colours

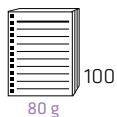

* Pen not included / Stylo non inclus / Bolígrafo no incluido / Ohne Kugelschreiber / Penna non inclusa.

MOQ: 50 u.

3701	3700
15	25
± 7,8 Kg	± 6,5 Kg

Notebooks Plastic Cover

britePix™

- EN > Maximize the impact of your promotional gift with this **full-colour print notebook!**
- FR > Optimisez l'impact de votre cadeau promotionnel avec ce **carnet de notes à impression quadri!**
- ES > ¡Maximiza el impacto de tu regalo promocional con esta **libreta con impresión a todo color!**
- DE > Maximieren Sie die Wirkung Ihres Werbegeschenks mit diesem **Notizbuch im Vollfarbdruck!**
- IT > Massimizza l'impatto del tuo regalo promozionale con questo **blocco per appunti con stampa full colour.**



3717 britePix™
Large
Grand
Grande
Groß
Grande

3716 britePix™
Small
Petit
Pequeño
Klein
Piccolo

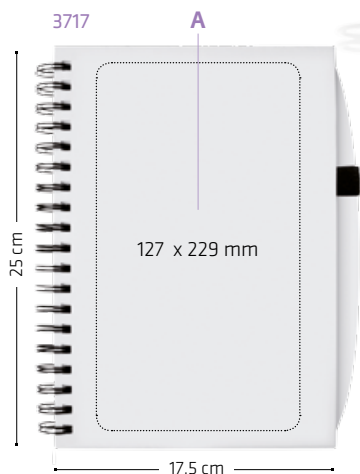

A > BP: full colour
B > BP: full colour



51



100

80 g

* Pen not included / Stylo non inclus / Bolígrafo no incluido / Ohne Kugelschreiber / Penna non inclusa.

MOQ: 50 u.

3717
15
± 7.8 Kg

3716
25
± 6.5 Kg

BIC Notebooks
 Plastic Cover
 Fashion Colours

- EN > **Colourful bright and compact notebook** ideal for your daily meetings.
- FR > **Des coloris brillants sur un carnet de notes compact**, pour vos réunions quotidiennes.
- ES > **Colores brillantes en una libreta compacta** para tus reuniones diarias.
- DE > **Kompaktes Notizbuch in glänzenden Farben** für Ihre täglichen Meetings.
- IT > **Colori brillanti in un blocco compatto** per le tue riunioni quotidiane.



BIC® NOTEBOOKS

3706
 Small
 Petit
 Pequeño
 Klein
 Piccolo



A > SP: max. 4 colours



* Pen not included / Stylo non inclus / Bolígrafo no incluido / Ohne Kugelschreiber / Penna non inclusa.

MOQ: 50 u.

25
 ± 6.5 Kg

Notebooks Plastic Cover Fashion Colours

britePix™

- EN > Combine both **photographic results** in a pen and in a notebook! Your **brand image everywhere!**
- FR > Combinez des **résultats photographiques** sur votre stylo et votre carnet de notes. Donnez **plus de visibilité à votre image de marque!**
- ES > Combina **resultados fotográficos** en tu bolígrafo y libreta. ¡Tu **imagen por todas partes!**
- DE > Kombinieren Sie **fotografische Ergebnisse** auf Ihrem Kugelschreiber und Ihrem Notizbuch! Ihr **Markenimage überall!**
- IT > Abbina la stampa con **qualità fotografica** sulla penna e sul blocco. La tua **immagine ovunque!**

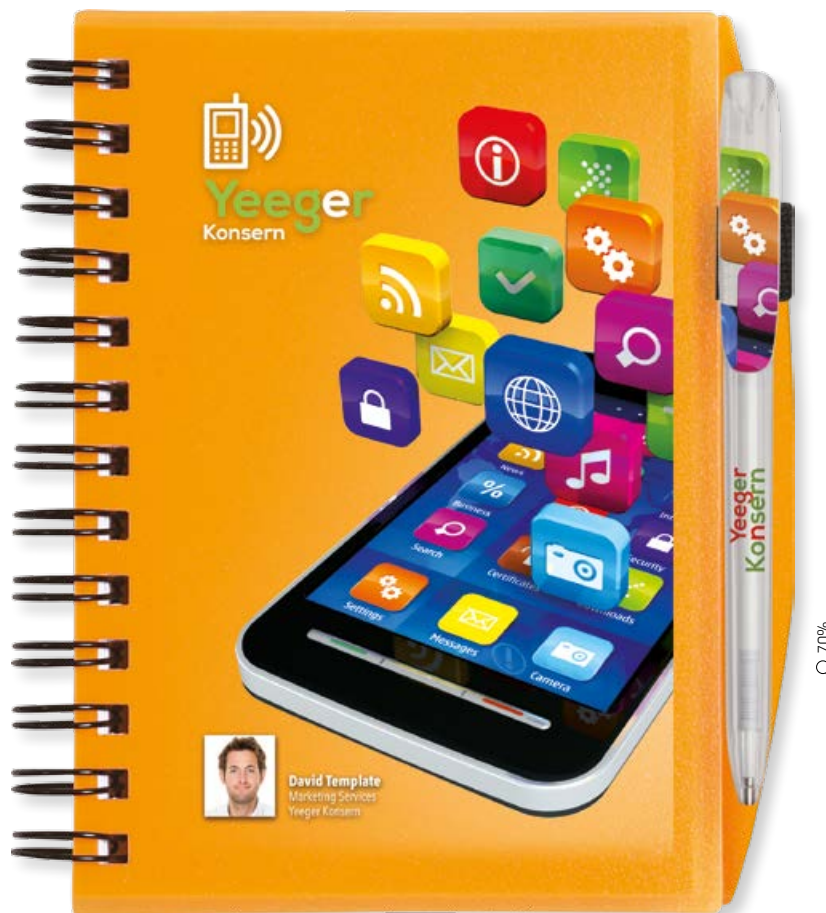

70%

BIC® NOTEBOOKS

3720 **britePix™**
Small
Petit
Pequeño
Klein
Piccolo



A> BP: full colour



100

* Pen not included / Stylo non inclus / Bolígrafo no incluido / Ohne Kugelschreiber / Penna non inclusa.

MOQ: 50 u.

25
± 6.5 Kg

BIC® Notebooks Chipboard Cover

- EN > Ideal combination with BIC® Writing Instrument. **Impacting results with debossing or hotstamping techniques.**
- FR > Combinaison idéale avec l'instrument d'écriture BIC®. **Un résultat impressionnant avec les techniques de débossage et d'estampage à chaud.**
- ES > Combinación ideal con un Instrumento de Escritura BIC®. **Impactante resultado con técnicas de debossing o hotstamping.**
- DE > Die ideale Ergänzung zu Ihrem BIC® Schreibgerät. **Beeindruckende Ergebnisse mit Debossing- oder Hotstamping-Techniken.**
- IT > Combinazione ideale con gli strumenti di scrittura BIC. **Risultato d'impatto con incisione o stampa a caldo.**



3702

BIC® NOTEBOOKS

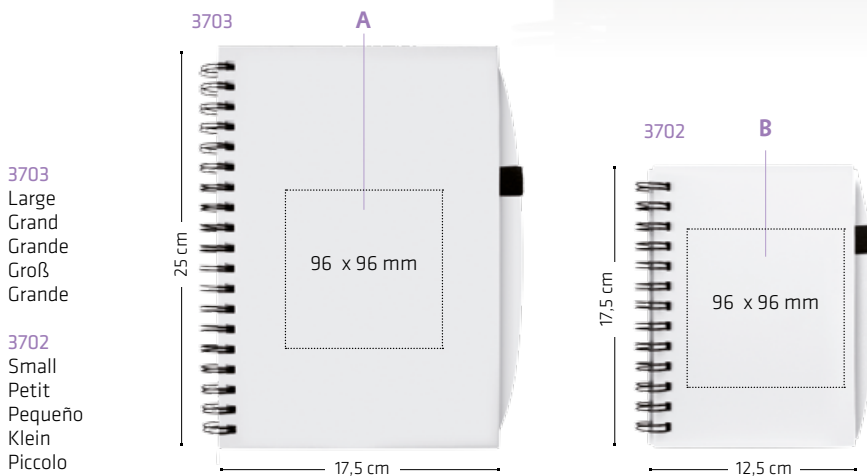

3703
Large
Grand
Grande
Groß
Grande

3702
Small
Petit
Pequeño
Klein
Piccolo

A/B> HS / DB: max. 1 colour

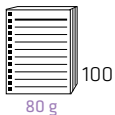

* Pen not included / Stylo non inclus / Bolígrafo no incluido / Ohne Kugelschreiber / Penna non inclusa.

MOQ: 50 u.

	3703	3702
	15	25
	+ 8 Kg	+ 6,8 Kg

Notebooks Chipboard Cover

britePix™

- EN > **Choose a black or white** cover for better photographic impact of your logo!
- FR > **Choisissez la couverture noire ou blanche**, pour un meilleur impact photographique de votre logo !
- ES > **Elige tu tapa en color negro o blanco** para un mejor impacto fotográfico de tu logo!
- DE > **Wählen Sie das schwarze oder das weiße** Cover für die beste fotografische Wirkkraft Ihres Logos!
- IT > **Massimizza l'impatto del tuo regalo promozionale** con questo blocco per appunti con stampa full colour.

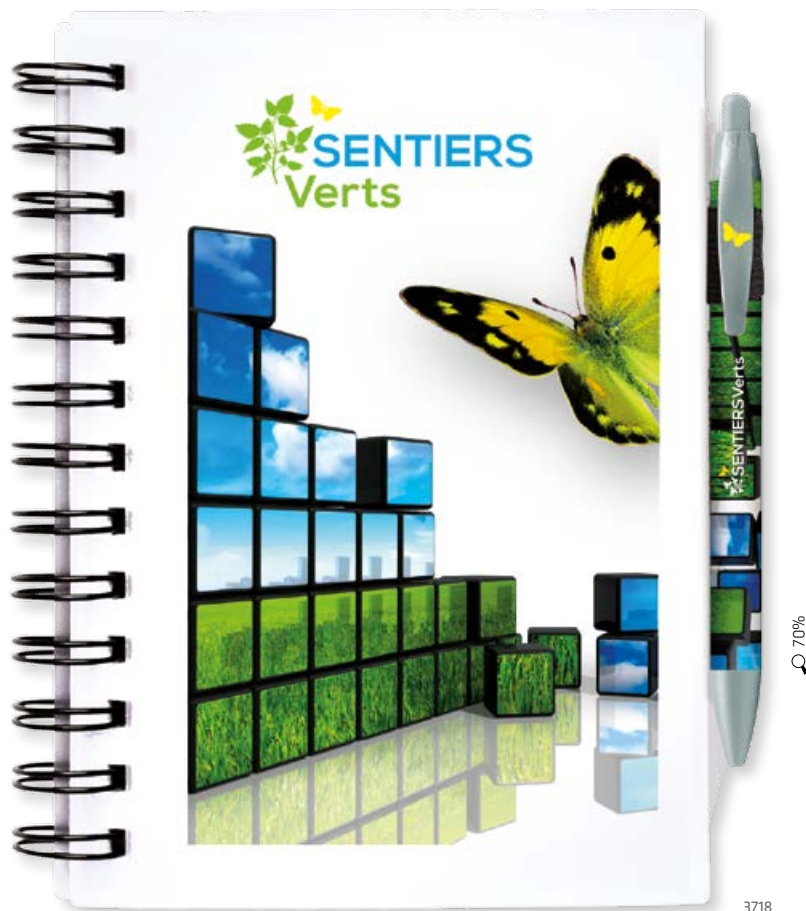

3718



BIC® NOTEBOOKS

3719 **britePix™**
Large
Grand
Grande
Groß
Grande

3718 **britePix™**
Small
Petit
Pequeño
Klein
Piccolo

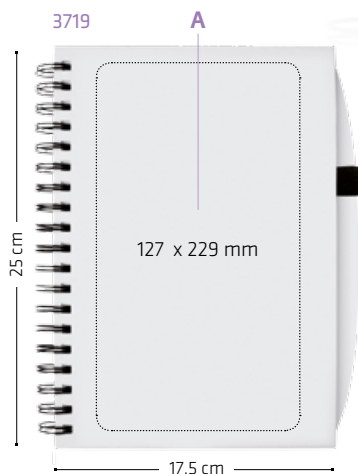

A> BP: full colour

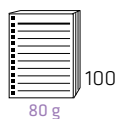

* Pen not included / Stylo non inclus / Bolígrafo no incluido / Ohne Kugelschreiber / Penna non inclusa.

MOQ: 50 u.

3719	3718
15	25
± 8 Kg	± 6.8 Kg



Ballpens

NEW COLOURS	BIC® Ecolutions® Clic	185
	BIC® Ecolutions® Clic Gold	185
	BIC® Ecolutions® Clic Stic	183
	BIC® Ecolutions® Clic Stic Digital	184
NEW COLOURS	BIC® Ecolutions® Media Clic	180
	BIC® Ecolutions® Media Clic Grip	181
	BIC® Ecolutions® Media Clic Grip Digital	182
	BIC® Ecolutions® Media Max	188
	BIC® Ecolutions® Media Max Digital	189
	BIC® Ecolutions® Round Stic®	179
	BIC® Ecolutions® Wide Body™	186
	BIC® Ecolutions® Wide Body™ Digital	187

Highlighters & Markers

NEW	BIC® Ecolutions® Permanent Marker	190
------------	---	-----

Graphite & Mechanical Pencils

BIC® Ecolutions® Evolution Classic	191
BIC® Ecolutions® Evolution Colour Connection	193
BIC® Ecolutions® Evolution Digital	192
BIC® Ecolutions® Evolution Digital Colour Connection	193
BIC® Ecolutions® Matic®	194
BIC® Ecolutions® Media Clic	180
BIC® Ecolutions® Media Clic Grip	181
BIC® Ecolutions® Media Clic Grip Digital	182

Notebooks & Sticky Note™

BIC® Ecolutions® 50 mm x 75 mm Adhesive Notepads . . .	195
BIC® Ecolutions® 68 mm x 75 mm Adhesive Notepads . . .	195
BIC® Ecolutions® 75 mm x 75 mm Adhesive Notepads . . .	195
BIC® Ecolutions® 75 mm x 75 mm Adhesive Die Cut Notepads	195
BIC® Ecolutions® 101 mm x 75 mm Adhesive Notepads . .	195
BIC® Ecolutions® 101 mm x 75 mm Adhesive Die Cut Notepads	195
BIC® Ecolutions® 101 mm x 75 mm Alternating Sheet Imprint	195
BIC® Ecolutions® 101 mm x 101 mm Adhesive Notepads	195
BIC® Ecolutions® 101 mm x 152 mm Adhesive Notepads	195



BIC® EVOLUTIONS®

How It's made...

BIC® Ecolutions® Round Stic® / BIC® Ecolutions® Media Clic / BIC® Ecolutions® Clic Stic / BIC® Ecolutions® Clic Stic Digital / BIC® Ecolutions® Media Clic Grip / BIC® Ecolutions® Media Clic Grip Digital / BIC® Ecolutions® Wide Body™ / BIC® Ecolutions® Wide Body™ Digital / BIC® Ecolutions® Media Max / BIC® Ecolutions® Media Max Digital / BIC® Ecolutions® Matic®



- EN > Plastic parts are acquired from manufacturing facilities to be reused and not discarded.
- FR > Des pièces en plastique sont collectées auprès d'installations industrielles en vue d'être réutilisées au lieu d'être mises au rebut.
- ES > Las piezas de plástico son obtenidas de procesos de fabricación para ser reutilizadas y no desechadas.
- DE > Der Hersteller kauft recycelbaren Kunststoff.
- IT > I componenti plastici provengono da scarti di produzione per essere riutilizzati.



- EN > Plastic parts are flaked, mixed and melted.
- FR > Les pièces en plastique sont alors aplaties, mélangées et fondues.
- ES > Las piezas de plástico son troceadas, mezcladas y derretidas.
- DE > Der Kunststoff wird gepresst, vermischt und geschmolzen.
- IT > I componenti plastici sono sminuzzati, mescolati e fusi.



- EN > The final result is pre-consumer recycled plastic pellets to make BIC® Ecolutions® pens.
- FR > On obtient donc des granulés de plastique recyclés pré-consommateur qui sont intégrés à la composition des stylos BIC® Ecolutions®.
- ES > El resultado final es un granulado de plástico reciclado pre-consumidor que se utiliza para fabricar bolígrafos BIC® Ecolutions®.
- DE > Das Resultat ist fabrikneues, Preconsumer-Kunststoffgranulat zur Herstellung von BIC® Ecolutions®-Kugelschreibern.
- IT > Il risultato finale è un granulato di plastica riciclata pre-produzione utilizzato per produrre le penne della gamma BIC® Ecolutions®.

BIC® Ecolutions® Clic & Clic Gold



- EN > Wood is collected from softwood and sustainably managed forests.
- FR > Le bois est collecté dans des forêts de bois doux gérées durablement.
- ES > La madera es recolectada de bosques sostenibles y de madera blanda.
- DE > Das Holz wird aus Weichholz sowie aus nachhaltig bewirtschafteten Wäldern gewonnen.
- IT > Il legno proviene da conifere e da foreste gestite in modo sostenibile.



- EN > The wood is transformed by an industrial process to plastic from a renewable resource.
- FR > Le bois est transformé en plastique selon un procédé industriel réalisé à partir de ressources renouvelables.
- ES > La corteza es utilizada como combustible para convertir las astillas de madera en un plástico renovable.
- DE > Die Baumrinde wird als Brennstoff verwendet, um das Holzgranulat in recycelbaren Kunststoff umzuwandeln.
- IT > Il legno viene trasformato in plastica tramite un procedimento industriale utilizzando fonti rinnovabili.



- EN > The final result is plastic pellets, made from a renewable resource, used to make BIC® Clic pens.
- FR > On obtient donc des granulés de plastique à partir de ressources renouvelables qui sont intégrés à la composition des stylos BIC® Clic.
- ES > El resultado final es un granulado de plástico, hecho de un recurso renovable y utilizado para fabricar bolígrafos BIC® Clic.
- DE > Das Endergebnis ist ein Kunststoffgranulat, das aus einer erneuerbaren Ressource gewonnen und zur Herstellung von BIC® Clic Kugelschreibern verwendet wird.
- IT > Il risultato finale è un granulato di plastica, ottenuto da risorse rinnovabili, utilizzato per produrre le penne BIC® Clic.

BIC® Ecolutions® Evolution Classic / BIC® Ecolutions® Evolution Digital / BIC® Ecolutions® Evolution Colour Connection / BIC® Ecolutions® Evolution Digital Colour Connection

- EN > Plastic is collected from homes, schools and businesses for recycling.
- FR > Le plastique à recycler est collecté chez les particuliers, dans les écoles et dans les entreprises.
- ES > El plástico es recogido en casas, colegios y oficinas para su reciclado.
- DE > Der recycelbaren Kunststoff stammt aus Haushalten, Schulen und Gewerbe.
- IT > La plastica proviene dal riciclo di materiali raccolti in case, scuole e uffici.



- EN > Plastic parts are flaked, mixed and melted.
 - FR > Les pièces en plastique sont alors aplaties, mélangées et fondues.
 - ES > Las piezas de plástico son troceadas, mezcladas y derretidas.
 - DE > Der Kunststoff wird gepresst, vermischt und geschmolzen.
 - IT > I componenti plastici sono sminuzzati, mescolati e fusi.
- EN > The final result is recycled plastic (pre and post consumer) pellets to make BIC® Ecolutions® pencils.
 - FR > Il en résulte des pastilles en plastique recyclé (pré et post-consommation) pour fabriquer nos crayons BIC® Ecolutions®.
 - ES > El resultado final es de pastillas de plástico reciclado (pre y post-consumo) para fabricar nuestros lápices BIC® Ecolutions®.
 - DE > Das Resultat ist fabrikneues, Preconsumer-Kunststoffgranulat und wiederverwertetes Postconsumer-Kunststoffgranulat zur Herstellung von BIC® Ecolutions®-Bleistiften.
 - IT > Il risultato finale è un granulato di plastica (pre e post-consumo) utilizzato per produrre le matite BIC® Ecolutions®.

- EN > Plastic parts are acquired from manufacturing facilities to be reused and not discarded.
- FR > Des pièces en plastique sont collectées auprès d'installations industrielles en vue d'être réutilisées au lieu d'être mises au rebut.
- ES > Las piezas de plástico son obtenidas de nuestro proceso de fabricación para ser reutilizadas y no desechadas.
- DE > Der Hersteller kauft recycelbaren Kunststoff.
- IT > I componenti plastici provengono da scarti di produzione per essere riutilizzati.



BIC[®] eColutions[®] Round Stic[®]



EN > The iconic BIC[®] Round Stic[®] offers **timeless style** and **high quality**. Its classic design is **easy to identify** and symbolizes long-term reliability.

FR > L'iconique BIC[®] Round Stic[®] offre un **style indémodable** et une **très grande qualité**. Son design classique est **facile à identifier** et symbolise une fiabilité à long terme.

ES > El icónico BIC[®] Round Stic[®] ofrece un **estilo atemporal y de calidad**. Su diseño clásico se **identifica fácilmente** y simboliza la fiabilidad a largo plazo.

DE > Unser kultiger BIC[®] Round Stic[®] bietet **zeitloses Design in bester Qualität**. Sein klassisches Design ist **einfach zu erkennen** und spiegelt lang anhaltende Zuverlässigkeit wieder.

IT > L'iconica BIC[®] Round Stic[®] offre uno stile **intramontabile ed alta qualità**. Il suo design classico la rende **facilmente riconoscibile** ed è prova di una longeva affidabilità.



Plastic parts are acquired from manufacturing facilities to be reused and not discarded. (pg 178)

Plastic parts are flaked, mixed and melted.

The final result is pre-consumer recycled plastic pellets to make BIC[®] Ecolutions[®] pens.

* **Made with 69% recycled material.**

The percentage is calculated based on the total weight of the product.



Add the Möbius loop to your artwork at no additional charge. Please be sure to specify "Print the Möbius loop" on your order. (Möbius loop imprint defaults to left-hand hand corner)



100%

100%

100%

1E10
Ballpen
Bille
Bolígrafo
Kugelschreiber
Penna a sfera

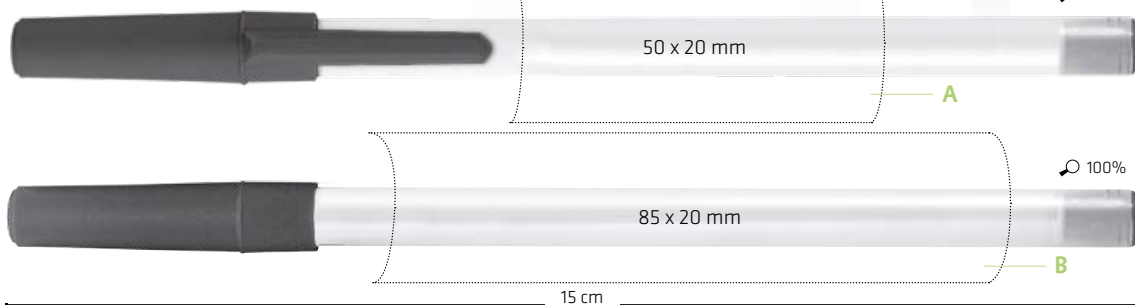

A> SP: max. 3 colours
B> SP: max. 1 colour



Cap, Section and Button
OPAQUE



Barrel
OPAQUE FROSTED



MOQ: 500 U.

PMS SERVICE
≥ 10.000 U.



+ 2,5 Kg
Red ink available under request

BIC® ecolutions®
Media Clic 

- EN > The promotional writing instrument of excellence, our number one, **the original**. Multiple **printing possibilities** on the barrel and on the clip, **and thousands of colour combinations**. Now up to **4 colour imprint** available on the barrel.
- FR > L'instrument d'écriture promotionnel par excellence, notre favori, **l'original**. De nombreuses **possibilités d'impression** sur le corps et le clip, et des **milliers de combinaisons de couleurs**. Nous pouvons désormais **imprimer jusqu'à 4 couleurs** sur le corps.
- ES > El instrumento de escritura promocional por excelencia, nuestro número uno, **el original**. Múltiples **posibilidades de impresión** en el cuerpo y en el clip, y **miles de combinaciones de colores**. Ahora es posible imprimir hasta **4 colores** en el cuerpo.
- DE > Das Schreibgerät par excellence unter den Werbegeschenken, die Nummer Eins unserer Kunden, **das Original**. Vielfältige **Druckmöglichkeiten** auf Schaft und Clip und **Tausende von Farbkombinationen**. Nun ist es möglich, **bis zu 4 Farben** auf den Schaft zu drucken.
- IT > Lo strumento di scrittura promozionale per eccellenza, il nostro numero uno, **l'originale**. Tante possibilità **di stampa** sul fusto e sulla clip e **migliaia di combinazioni di colore**. Ora anche con **stampa in quadricromia** sul fusto.



Plastic parts are acquired from manufacturing facilities to be reused and not discarded. (pg 178)

Plastic parts are flaked, mixed and melted.

The final result is pre-consumer recycled plastic pellets to make BIC® Ecollections® pens.

* **Made with 39% recycled material.**
 The percentage is calculated based on the total weight of the product.

1E25
 Ballpen
 Bille
 Bolígrafo
 Kugelschreiber
 Penna a sfera

1E28
 Mechanical pencil
 Porte-mines
 Portaminas
 Druckbleistift
 Portamine

A> SP: max. 2 colours
 B/C> SP: max. 4 colours



1E25

1E28

Add the Möbius loop to your artwork at no additional charge. Please be sure to specify "Print the Möbius loop" on your order. (Möbius loop imprint defaults to left-hand hand corner)

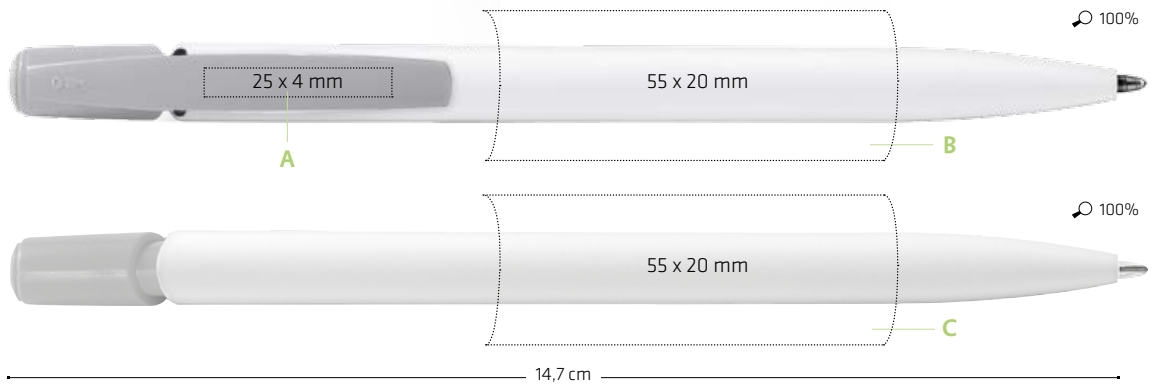

MIX & MATCH

Clip and Button
 OPAQUE

01	02	28	03	04	05	07
10	12	13	18	29	2D	3C
3D	85	83	84			

FROSTED

Barrel
 OPAQUE

01	02
----	----

NEW COLOUR

MOQ: 500 U.
 PMS SERVICE
 ≥10.000 U.



Red ink available under request
 BIC® Easy-Glide system option

Media Clic Grip



EN > Reliable plunger action mechanism. **Soft touch gripping section. Now up to 4 colours** imprint available on the barrel.

FR > Mécanisme fiable et rétractable par appui sur le poussoir. **Grip au toucher doux.** Nous pouvons **désormais imprimer jusqu'à 4 couleurs** sur le corps.

ES > Fiable mecanismo de accionamiento retráctil en el pulsador. **Sección con grip de tacto suave. Ahora es posible imprimir hasta 4 colores** en el cuerpo.

DE > Zuverlässiges Druckschreibgerät. **Soft-Touch-Griffzone.** Nun ist es möglich, **bis zu 4 Farben** auf den Schaft zu **drucken**.

IT > Affidabile meccanismo a scatto. **impugnatura morbida al tatto. Ora disponibile anche stampa in quadricromia** sul fusto.



Plastic parts are acquired from manufacturing facilities to be reused and not discarded. (pg 178)



Plastic parts are flaked, mixed and melted.



The final result is pre-consumer recycled plastic pellets to make BIC® Ecolutions® pens.

* **Made with 37% recycled material.**

The percentage is calculated based on the total weight of the product.

1E20

Ballpen
Bille
Bolígrafo
Kugelschreiber
Penna a sfera

1E21

Mechanical pencil
Porte-mines
Portaminas
Druckbleistift
Portamine

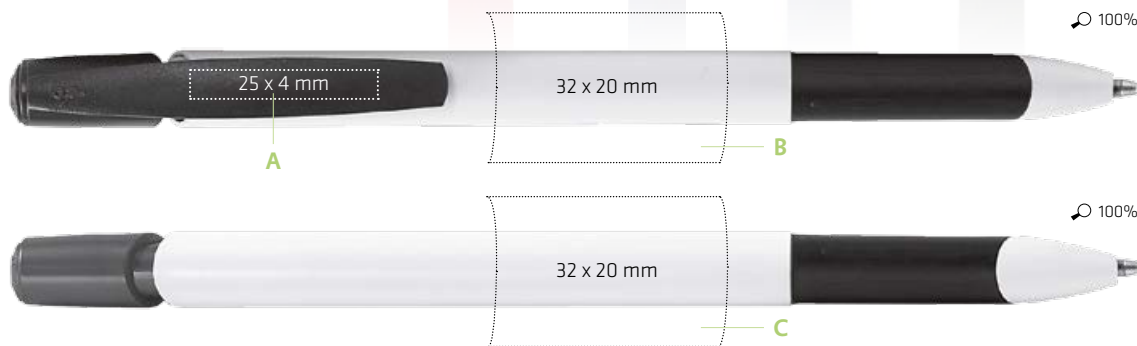

A> SP: max. 2 colours

B/C> SP: max. 4 colours



Add the Möbius loop to your artwork at no additional charge. Please be sure to specify "Print the Möbius loop" on your order. (Möbius loop imprint defaults to left-hand hand corner)



Only for clip and button

Clip and Button

OPAQUE

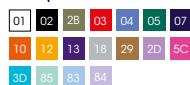

FROSTED

69

Barrel and Grip

OPAQUE



MOQ: 500 U.

PMS SERVICE
≥ 20.000 U.



Red ink available under request
BIC® Easy-Glide system option

BIC® ecolutions®
Media Clic 
Grip Digital 

- EN > 360° photo-quality full-colour imprint.
- FR > Impression 360° de qualité photographique.
- ES > Impresión 360° a todo color con calidad fotográfica.
- DE > 360°-Vollfarbdruck in Fotoqualität.
- IT > Stampa di qualità fotografica a colori a 360°.



Plastic parts are acquired from manufacturing facilities to be reused and not discarded. (pg 178)



Plastic parts are flaked, mixed and melted.



The final result is pre-consumer recycled plastic pellets to make BIC® Ecollections® pens.

* **Made with 37% recycled material.**
 The percentage is calculated based on the total weight of the product.

Add the Möbius loop to your artwork at no additional charge. Please be sure to specify "Print the Möbius loop" on your order. (Möbius loop imprint defaults to left-hand hand corner.)



1E22
 Ballpen
 Bille
 Bolígrafo
 Kugelschreiber
 Penna a sfera

1E23
 Mechanical pencil
 Porte-mines
 Portaminas
 Druckbleistift
 Portamine



A> SP: max. 2 colours
 B> DG: full colour



Clip and Button
 OPAQUE

01	02	2B	03	04	05	07
10	12	13	18	29	2D	5C
3D	85	83	8D	84		

FROSTED

Barrel and Grip
 OPAQUE

01/02	01/03	01/05
01/07	01/12	

FROSTED

MOQ: 500 U.

PMS SERVICE
 ≥ 20.000 U.



Red ink available under request
 BIC® Easy-Glide system option

BIC® ecolutions®
Clic Stic 

- EN > Modern, flexible, reliable. That's how BIC® Clic Stic is! A large **variety of finishes** such as Digital, Softfeel®, Mini and Antimicrobial, and **more than 4.000 colour combinations!**
- FR > Moderne, flexible et fiable. Ainsi se définit BIC® Clic Stic ! Une grande **variété de finitions** : numérique, Softfeel®, Mini ou Antimicrobial, **et plus de 4 000 combinaisons de couleurs !**
- ES > Moderno, flexible, fiable. Así es BIC® Clic Stic! Amplia **variedad de acabados**, como Digital, Softfeel®, Mini o Antimicrobial y **más de 4.000 combinaciones de colores!**
- DE > Modern, flexibel, zuverlässig. Das ist BIC® Clic Stic! Breite **Palette an Ausführungen**, wie Digital, Softfeel®, Mini oder Antimikrobiell und **über 4.000 mögliche Farbkombinationen!**
- IT > Moderna, flessibile, affidabile. È il ritratto di BIC® Clic Stic! Un'**ampia gamma di finiture** come Digitale, Softfeel®, Mini o Antimicrobial e **più di 4.000 combinazioni di colori!**



* **Made with 58% recycled material.**
 The percentage is calculated based on the total weight of the product.



Add the Möbius loop to your artwork at no additional charge. Please be sure to specify "Print the Möbius loop" on your order. (Möbius loop imprint defaults to left-hand hand corner.)



1E00
 Ballpen
 Bille
 Bolígrafo
 Kugelschreiber
 Penna a sfera

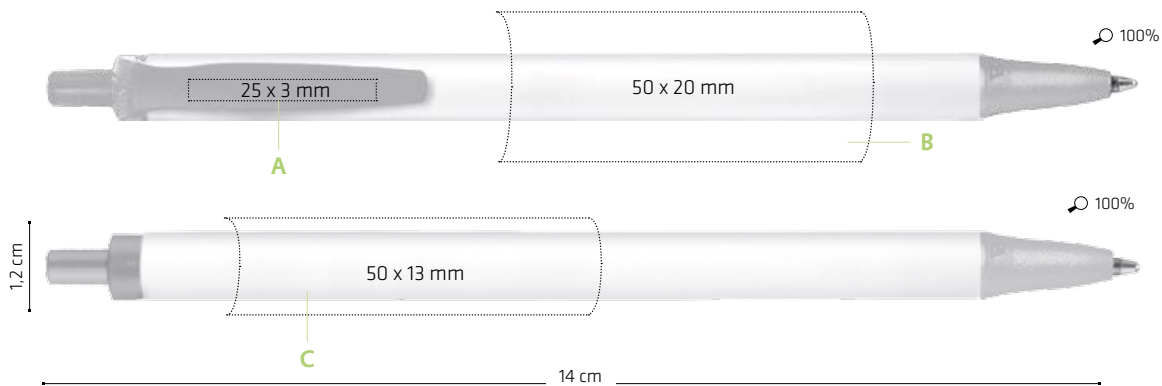

A > SP: max. 1 colour
 B > SP: max. 3 colours
 C > SP: max. 2 colours



Cap and Section	Barrel
OPAQUE	OPAQUE FROSTED
02 03 07 20	01 69

MOQ: 500 u.



500



PMS SERVICE
 ≥10.000 u.

± 2,9 Kg
 Red ink available under request BIC® Easy-Glide system option



Clic Stic Digital



- EN > 360° photo-quality full-colour imprint.
- FR > Impression 360° de qualité photographique.
- ES > Impresión 360° a todo color con calidad fotográfica.
- DE > 360°-Vollfarbdruck in Fotoqualität.
- IT > Stampa di qualità fotografica a colori a 360°.



Plastic parts are acquired from manufacturing facilities to be reused and not discarded. (pg 178)



Plastic parts are flaked, mixed and melted.



The final result is pre-consumer recycled plastic pellets to make BIC Ecolutions pens.



100%

Add the Möbius loop to your artwork at no additional charge. Please be sure to specify "Print the Möbius loop" on your order. (Möbius loop imprint defaults to left-hand hand corner.)



BIC® ECOLUTIONS®

*** Made with 58% recycled material.**

The percentage is calculated based on the total weight of the product.

1E01

- Ballpen
- Bille
- Bolígrafo
- Kugelschreiber
- Penna a sfera

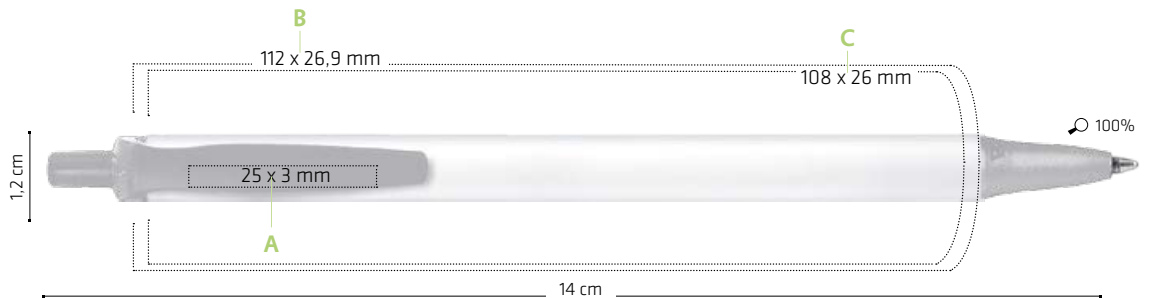

- A > SP: max. 1 colour
- B / E > DG: full colour (area for images)
- C / F > DG: full colour (area for text)



Cap and Section
OPAQUE



Barrel
OPAQUE



MOQ: 500 u.



± 2,9 Kg



≥ 25.000 u. for custom made Section.

PMS SERVICE ≥ 10.000 u.

Red ink available under request BIC® Easy-Glide system option

Clic & Clic Gold



- EN > Made with 26% cellulosic polymers, an **eco-friendly material** manufactured using natural, renewable softwood materials. BIC® Clic is **flexible and durable** as well as pleasant to touch, and is offered in a wide variety of colours and finishes.
- FR > Fabriqué avec 26 % de polymères de cellulose, **matériau écologique** obtenu à partir du bois, BIC® Clic est **flexible et durable**, agréable au toucher et il se décline dans une vaste gamme de coloris et de finitions.
- ES > Fabricado con un 26% de polímeros de celulosa, un **material ecológico** realizado a partir de la madera. BIC® Clic es **flexible y duradero** así como agradable al tacto, y se ofrece en una amplia gama de colores y acabados.
- DE > Zu 26% aus Zellulosepolymeren gefertigt, ein aus Holz hergestelltes **ökologisches Material**. BIC® Clic ist **flexibel, langlebig**, ist angenehm anzufassen und wird in einer breiten Palette an Farben und Finishes angeboten.
- IT > Prodotto con un 26% di polimeri di cellulosa, un **materiale ecologico** realizzato partendo dal legno. BIC® Clic è **flessibile e di lunga durata**, ma anche piacevole al tatto, e disponibile in una vasta gamma di colori e finiture.



Wood is collected from softwood and sustainably managed forests. (pg 178)

Bark is used as fuel to convert the wood chips into a renewable plastic.

The final result is pre-consumer recycled plastic pellets to make BIC®

- 1093 /
- 1092 Clear
- 1091 Gold /
- 1090 Gold Clear /
- Ballpen
- Bille
- Bolígrafo
- Kugelschreiber
- Penna a sfera

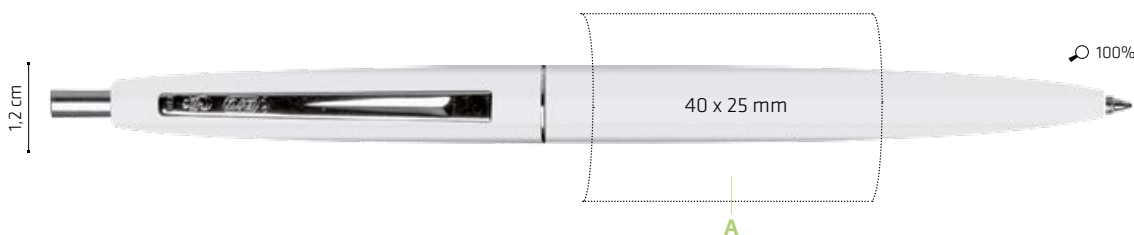

A> SP: max. 3 colours

1093
Barrel / Trims
OPAQUE



1092 Clear
Barrel / Trims / Ink
CLEAR

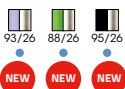

1091 Gold
Barrel / Trims / Ink
OPAQUE

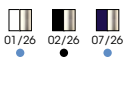

1090 Gold Clear
Barrel / Trims / Ink
CLEAR



MOQ: 250 u.



+ 2,3 Kg

*Except for ID

BIC® ecolutions®
Wide Body™ 

- EN > Wide-profile design with large imprint area.
- FR > Profil large avec large zone d'impression.
- ES > Diseñado para maximizar el área de impresión.
- DE > Klassisches Design mit großer Druckfläche.
- IT > Sfera con corpo ampio con grande area di personalizzazione.



Plastic parts are acquired from manufacturing facilities to be reused and not discarded. (pg 178)



Plastic parts are flaked, mixed and melted.



The final result is pre-consumer recycled plastic pellets to make BIC® Ecollections® pens.



Add the Möbius loop to your artwork at no additional charge. Please be sure to specify "Print the Möbius loop" on your order. (Möbius loop imprint defaults to left-hand hand corner.)



* Made with 33% recycled material.

The percentage is calculated based on the total weight of the product.

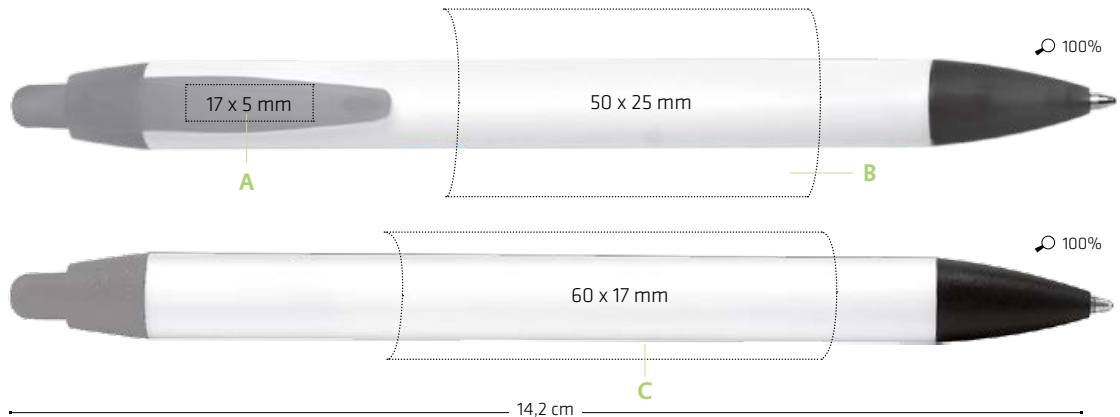

1E80
 Ballpen
 Bille
 Bolígrafo
 Kugelschreiber
 Penna a sfera

A> SP: max. 1 colour
 B / C> SP: max. 2 colours



Clip and Section

OPAQUE



FROSTED



Barrel

OPAQUE



MOQ: 250 u.

PMS SERVICE
 ≥10.000 u.*

* ≥25.000 u. for custom made Section



250

± 2,6 Kg



Red ink available under request BIC® Easy-Glide system option

BIC® ecolutions®
Wide Body™ 
Digital 

- EN > 360° photo-quality full-colour imprint.
- FR > Impression 360° de qualité photographique.
- ES > Impresión 360° a todo color con calidad fotográfica.
- DE > 360°-Vollfarbdruck in Fotoqualität.
- IT > Stampa di qualità fotografica a colori a 360°.



Plastic parts are acquired from manufacturing facilities to be reused and not discarded. (pg 178)



Plastic parts are flaked, mixed and melted.



The final result is pre-consumer recycled plastic pellets to make BIC® Ecollections® pens.

* **Made with 33% recycled material.**
 The percentage is calculated based on the total weight of the product.



Add the Möbius loop to your artwork at no additional charge. Please be sure to specify "Print the Möbius loop" on your order. (Möbius loop imprint defaults to left-hand hand corner)



1E81
 Ballpen
 Bille
 Bolígrafo
 Kugelschreiber
 Penna a sfera



- A > SP: max. 1 colour
- B > DG: full colour (area for images)
- C > DG: full colour (area for text)



Clip and Section	
OPAQUE	FROSTED
01 02 03	40 63 66 67
07 18	68 69 71

Barrel	
OPAQUE	FROSTED
01	40 63 66 67
	68 69 71

MOQ: 500 u.

PMS SERVICE
 ≥ 10.000 u.*

* ≥ 25.000 u. for custom made Section



Red ink available under request

BIC® ecolutions®
Media Max 

EN > Soft gripping section. Extra wide barrel for maximum imprint area.

FR > Partie grip lisse et douce. Corps extra large pour une surface de marquage maximale.

ES > Grip suave. Cuerpo extra ancho para una zona máxima de impresión.

DE > Angenehm weiche Griffzone. Extra breiter Schaft für eine maximale Werbefläche.

IT > Impugnatura morbida. Corpo ampio con grande area di personalizzazione.



Plastic parts are acquired from manufacturing facilities to be reused and not discarded. (pg 178)



Plastic parts are flaked, mixed and melted.



The final result is pre-consumer recycled plastic pellets to make BIC® Ecollections® pens.

* Made with 26% recycled material.

The percentage is calculated based on the total weight of the product.

Add the Möbius loop to your artwork at no additional charge. Please be sure to specify "Print the Möbius loop" on your order. (Möbius loop imprint defaults to left-hand corner)



BIC® ECOLUTIONS®

1E30
 Ballpen
 Bille
 Bolígrafo
 Kugelschreiber
 Penna a sfera

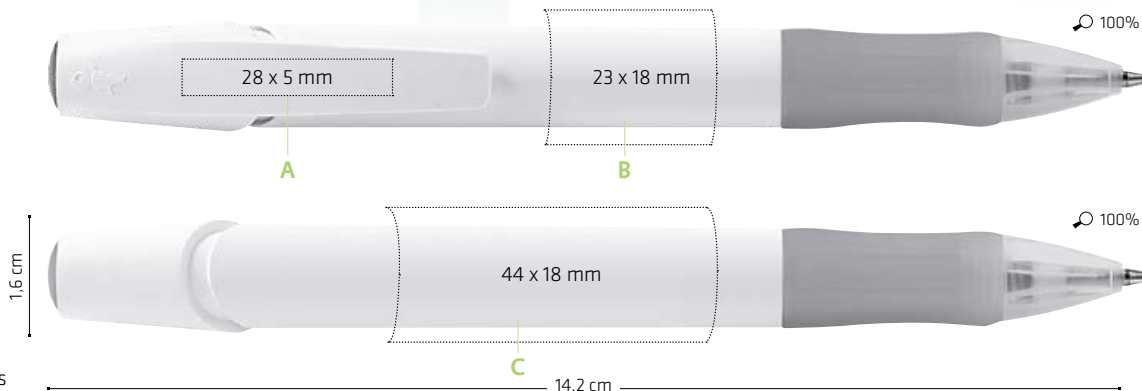

A> SP: max. 2 colours
 B/C> SP: max. 4 colours

MIX & MATCH

Plug, Grip, Section and Clip
 OPAQUE FROSTED



Barrel
 OPAQUE



MOQ: 500 U.

PMS SERVICE
 ≥10.000 U.



± 6 Kg



Red ink available under request
 BIC® Easy-Glide system option



Media Max Digital



- EN > 360° photo-quality full-colour imprint.
- FR > Impression 360° de qualité photographique.
- ES > Impresión 360° a todo color con calidad fotográfica.
- DE > 360°-Vollfarbdruck in Fotoqualität.
- IT > Stampa di qualità fotografica a colori a 360°.



Plastic parts are acquired from manufacturing facilities to be reused and not discarded. (pg 178)



Plastic parts are flaked, mixed and melted.



The final result is pre-consumer recycled plastic pellets to make BIC® Ecolutions® pens.

* Made with 26% recycled material.
The percentage is calculated based on the total weight of the product.

Add the Möbius loop to your artwork at no additional charge. Please be sure to specify "Print the Möbius loop" on your order. (Möbius loop imprint defaults to left-hand hand corner)



1E34
Ballpen
Bille
Bolígrafo
Kugelschreiber
Penna a sfera

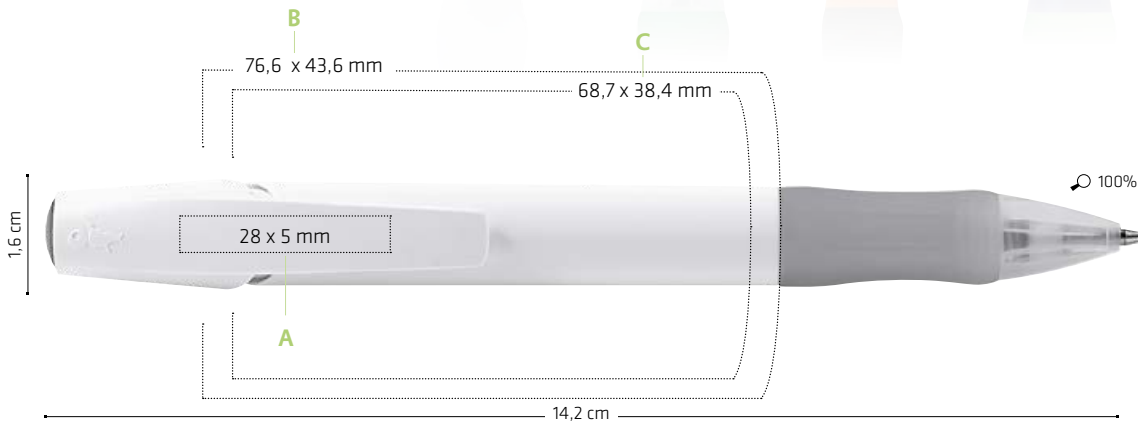

- A> SP: max. 2 colours
- B> DG: full colour (area for images)
- C> DG: full colour (area for text)



Plug, Grip, Section and Clip
OPAQUE FROSTED



Barrel
OPAQUE



MOQ: 500 u.

PMS SERVICE
≥ 10.000 u.



Red ink available under request
BIC® Easy-Glide system option

Permanent Marker



EN > Writes on most surfaces. **Quick-drying and low-odour ink.** Cap with security lock. **Large imprint area.**

FR > Il écrit sur la plupart des surfaces. **Encre qui sèche rapidement et à odeur neutre.** Capuchon doté d'une fermeture de sécurité. **Grande zone d'impression.**

ES > Escribe sobre la mayoría de superficies. **Secado rápido y olor suave.** Capuchón con cierre de seguridad. **Gran área de impresión.**

DE > Schreibt auf den meisten Oberflächen. **Schnelltrocknende, wenig parfümierte Tinte.** Verschlusskappe mit Sicherheitsverschluss. **Große Druckfläche.**

IT > Scrive su quasi tutte le superfici. **Inchiostro a rapida essiccazione e bassa emanazione di odori.** Cappuccio con chiusura di sicurezza. **Ampia area di stampa.**



100%



Plastic parts are acquired from manufacturing facilities to be reused and not discarded. (pg 178)



Plastic parts are flaked, mixed and melted.



The final result is pre-consumer recycled plastic pellets to make BIC® Ecollections® pens.

* **Made with 51% recycled material.**

The percentage is calculated based on the total weight of the product.

Add the Möbius loop to your artwork at no additional charge. Please be sure to specify "Print the Möbius loop" on your order. (Möbius loop imprint defaults to left-hand hand corner)



1210
Marquer
Marqueur
Marcador
Permanent Marker
Pennarello

2 cm



65 x 45 mm

100%

A

A> SP: max. 1 colour

13,8 cm

Barrel / Cap / Ink
OPAQUE



MOQ: 250 u.



125

± 2,6 Kg



MADE IN FRANCE



Evolution Classic



- EN > **Wood-free** pencil in synthetic resin material will **not splinter** in the event of breaking and resists chewing. Resistant HB grade lead.
- FR > Crayon graphite **sans bois** en résine synthétique : **pas d'écharde** en cas de casse et résistant au mordillage. Mine HB très résistante.
- ES > Lápiz de grafito de resina sintética, **sin madera: sin astillas** al romperse y resistente al ser mordido. Mina resistente de grado HB.
- DE > Holzfreier Bleistift aus synthetischem Harz: Kein Zersplittern bei Bruch und obendrein kaubeständig. Widerstandsfähige HB-Bleimine.
- IT > Matita **senza legno** in resina sintetica: **non lascia schegge** in caso di rottura e resiste alla masticazione. Resistente mina di durezza HB.



Plastic is collected from homes, schools and businesses for recycling.



Plastic parts are acquired from manufacturing facilities to be reused and not discarded. (pg 178)



Plastic parts are flaked, mixed and melted.



The final result is pre-consumer recycled plastic to make BIC® Ecolutions® pens.

** Made with 54% recycled plastic (1150)

* Made with 46% recycled plastic (1151)

The percentage is calculated based on the total weight of the product.

Add the Möbius loop to your artwork at no additional charge. Please be sure to specify "Print the Möbius loop" on your order. (Möbius loop imprint defaults to left-hand hand corner.)



Scan this page, live the BIC Graphic Augmented Reality experience and share it!

80%

BIC® ECOLUTIONS®

1150**

Graphite pencil cut end
Crayon graphite bout coupé
Lápiz de grafito sin goma
Graphit-Bleistift ohne Radiergummi
Matita senza gomma

1151*

Graphite pencil with eraser
Crayon graphite bout gomme
Lápiz de grafito con goma
Graphit-Bleistift mit Radiergummi
Matita con gomma

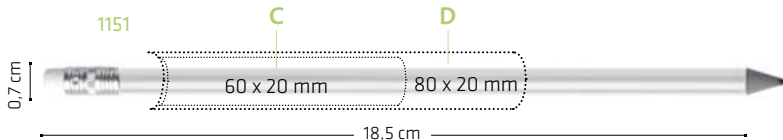
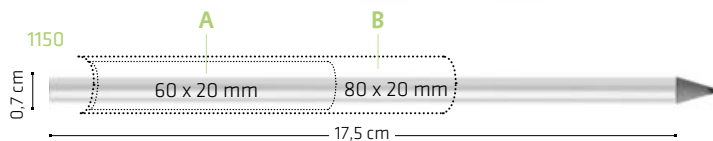

A / C > SP: max. 2 colours

B / D > SP: max. 1 colour

Barrel
OPAQUE



MOQ: 500 u.



PC



HB 2,3 mm

± 3.5 Kg



*Only cut end & not sharpened

Evolution Digital



- EN > 360° photo-quality **full-colour** imprint.
- FR > Impression 360° **toutes couleurs** qualité photographique
- ES > Impresión 360° a **todo color** con calidad fotográfica.
- DE > 360°-**Vollfarbdruck** in Fotoqualität.
- IT > Stampa di qualità fotografica a **colori** a 360°.



Plastic is collected from homes, schools and businesses for recycling.



Plastic parts are acquired from manufacturing facilities to be reused and not discarded. (pg 178)



Plastic parts are flaked, mixed and melted.



The final result is pre-consumer recycled plastic to make BIC® Ecolutions® pens.

** Made with 54% recycled plastic (1879)

* Made with 46% recycled plastic (1871)

The percentage is calculated based on the total weight of the product.

Add the Möbius loop to your artwork at no additional charge. Please be sure to specify "Print the Möbius loop" on your order. (Möbius loop imprint defaults to left-hand hand corner.)



Scan this page, live the BIC Graphic Augmented Reality experience and share it!

80%

1879**
Graphite pencil cut end
Crayon graphite bout coupé
Lápiz de grafito sin goma
Graphit-Bleistift ohne Radiergummi
Matita senza gomma

1871**
Graphite pencil with eraser
Crayon graphite bout gomme
Lápiz de grafito con goma
Graphit-Bleistift mit Radiergummi
Matita con gomma

A/C/ DG: full colour (area for images)
B/D/ DG: full colour (area for text)

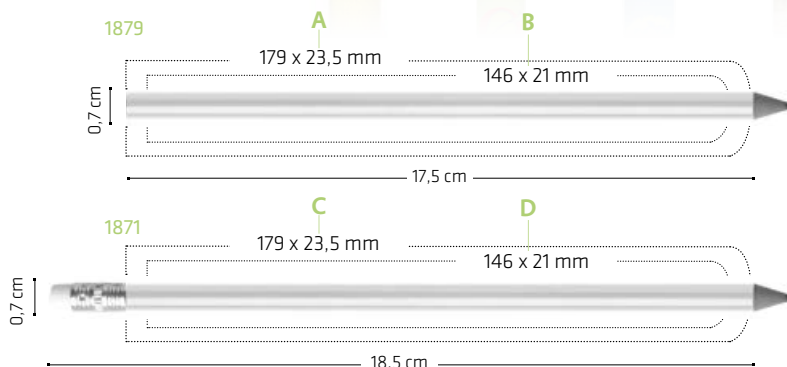

Barrel
OPAQUE



MOQ: 500 u. PC

500
± 3,5 Kg





Evolution

Colour Connection & Digital Colour Connection



EN > **Mix & Match** the components and print **360° full-colour!**

FR > Associez les composants avec **Mix & Match** et imprimez à **360° en couleur!**

ES > ¡Combine los componentes con **Mix & Match** e imprima **360° a todo color!**

DE > Kombinieren Sie die Farben der Komponenten mit **Mix & Match** und wählen Sie **360°-Vollfarbdruck!**

IT > Combina i componenti con **Mix & Match** e stampa a **360° a colori!**



Plastic is collected from homes, schools and businesses for recycling.



Plastic parts are acquired from manufacturing facilities to be reused and not discarded. (pg 178)



Plastic parts are flaked, mixed and melted.



The final result is pre-consumer recycled plastic to make BIC® Ecolutions® pens.

*** Made with 46% recycled plastic**

The percentage is calculated based on the total weight of the product.

Add the Möbius loop to your artwork at no additional charge. Please be sure to specify "Print the Möbius loop" on your order. (Möbius loop imprint defaults to left-hand hand corner.)



Scan this page, live the BIC Graphic Augmented Reality experience and share it!



1154 / 1885 Digital
Graphite pencil with eraser
Crayon graphite bout gomme
Lâpiz de grafito con goma
Graphit-Bleistift mit Radiergummi
Matita con gomma

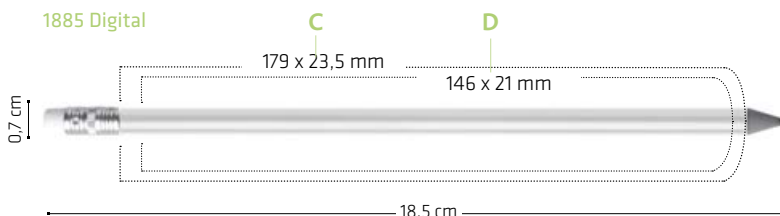
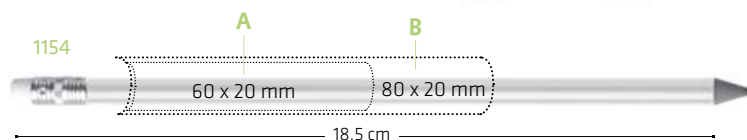

- A> SP: max. 2 colours
- B> SP: max. 1 colour
- C> DG: full colour (area for images)
- D> DG: full colour (area for text)



1154
Barrel
OPAQUE



1885
Barrel
OPAQUE



1154 / 1885
Eraser



Ferrule



MOQ: 500 u.

500
± 3.5 Kg



BIC® ECOLUTIONS®

Matic®



EN > Provides write-out equivalent to **2^{1/2} woodcase pencils! Scantron Certified** to be used in forms, test or machine-readable questionnaires. **Three 0.7 mm #2 graphite leads** (HB).

FR > Offre une durée d'écriture **2,5 fois supérieure aux crayons de bois ! Certifié Scantron** pour utilisation sur des formulaires, tests ou questionnaires lisibles par machine. **Trois mines de graphite n° 2 de 7 mm** (HB).

ES > Proporciona una longitud de escritura **equivalente a 2,5 lápices de madera! Certificado por Scantron** para uso en formularios, test o cuestionarios de lectura automática. **Tres recambios de grafito de 0,7 mm** (HB).

DE > Entspricht einer Schreiblänge von **zweieinhalb Holzbleistiften! Scantron-geprüft:** geeignet für Fragebögen, Examina und Lesemaschinen. **Drei 0,7 mm Graphit-Minen** (HB).

IT > Fornisce una durata di scrittura equivalente a **2 volte e mezzo una normale matita in legno! Certificato Scantron,** lettore di marcature ottiche usato per valutazione di esami universitari, test e questionari ufficiali. **Tre mine in grafite da 0,7 mm** (HB).



Plastic parts are acquired from manufacturing facilities to be reused and not discarded. (pg 178)



Plastic parts are flaked, mixed and melted.



The final result is pre-consumer recycled plastic pellets to make BIC® Ecolutions® pens.

Add the Möbius loop to your artwork at no additional charge. Please be sure to specify "Print the Möbius loop" on your order. (Möbius loop imprint defaults to left-hand hand corner.)



* **Made with 65% recycled material.**

The percentage is calculated based on the total weight of the product.

1E40

Mechanical pencil
Porte-mines
Portaminas
Druckbleistift
Portamine

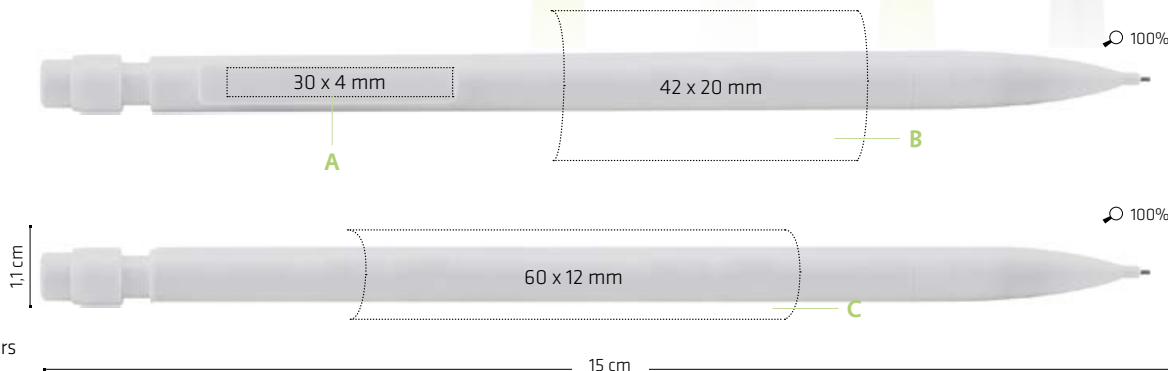

A> SP: max. 1 colour

B / C> SP: max. 2 colours

Barrel and Trims

OPAQUE



MOQ: 500 u.



500

± 3,1 Kg



 **BIC** *ecolutions*[®]
Sticky Note[™]

EN > All BIC® Ecolutions® Sticky Note™ products are made of paper stock containing 100% recycled fibre and water-based adhesive.

The percentage is calculated based on paper stock.

FR > Tous les produits BIC® Ecolutions® Sticky Note™ sont fabriqués avec du papier contenant 100 % de fibres recyclées et un adhésif à base d'eau.

Le pourcentage de matériel recyclé est calculé sur le total de la bobine de papier.

ES > Todos los productos BIC® Sticky Note™ Ecolutions® están hechos con papel de fibra 100% reciclada y adhesivo a base de agua.

El porcentaje de material reciclado está calculado sobre el total de la bobina de papel.

DE > Alle BIC® Sticky Note™ Ecolutions® Produkte werden aus 100% recycelten Fasern und mit einem Kleber auf Wasserbasis hergestellt.

Der Prozentanteil wird auf Basis der Papiermenge berechnet.

IT > Tutti i prodotti BIC® Sticky Note™ Ecolutions® sono prodotti con carta contenente il 100% di fibra riciclata e colla a base d'acqua. Effetto riciclato naturale.

La percentuale di materiale riciclato è calcolata sul totale della bobina di carta. Tutti i notebooks sono dotati di 100 fogli a righe. Carta da 60 g.



Paper is collected from homes, schools and businesses for recycling.



Paper is reduced to pulp and de-inked, then converted back into paper.



The final result is recycled paper used to make BIC® Sticky Note® Ecolutions® products.

Products available with recycled paper:

50 mm x 75 mm Adhesive Notepads	Pg 146
68 mm x 75 mm Adhesive Notepads	Pg 147
75 mm x 75 mm Adhesive Notepads	Pg 148
75 mm x 75 mm Adhesive Die Cut Notepads	Pg 149
101 mm x 75 mm Adhesive Notepads	Pg 150
(Also with Alternating Sheet Imprint)	Pg 152
101 mm x 75 mm Adhesive Die Cut Notepads	Pg 153
101 mm x 101 mm Adhesive Notepads	Pg 154
101 mm x 152 mm Adhesive Notepads	Pg 155



Add the "Mobius loop" to your artwork at no additional charge! Next to the mobius loop, it is required to include the text "Recycled Paper". (Mobius loop imprint defaults to lower left hand corner of your notepad unless otherwise specified.).



Lighters & Cases

Lighters

	BIC® J25	198
	BIC® J25 Digital & BIC® J25 Digital Transfer	200
	BIC® J23	201
	BIC® J26	202
	BIC® J26 Digital	203
	BIC® J38	204
	BIC® J38 Digital	206
	BIC® J39	207
	BIC® J39 Digital	208
	BIC® Mega Lighter & BIC® Mega Lighter britePix™	210

Cases

	BIC® Clip Case & BIC® Clip Case britePix™	211
	BIC® Styl'it Fashion & BIC® Styl'it Fashion britePix™	212
	BIC® Styl'it Luxury	213



ART & OCTOBER 23
CITY FUNK
NOUVEAU
FESTIVAL



BY THE EXPERT 
of *Lighters*

EN > **Convenient portable size. Child-resistant safety guard:** prevents lighter ignition by children according to EN13869. **Stable flame** due to pure isobutane fuel. Made of a **technical resin (Delrin®)** with high mechanical resistance.



BIC® LIGHTERS



FR > Taille mini très pratique. Languette métallique sécurité enfant: rend l'allumage plus difficile pour les enfants selon la norme EN13869. Stabilité de la flamme grâce au gaz pur isobutane. Utilisation d'une **résine technique (Delrin®)** à haute résistance mécanique.

ES > Tamaño conveniente. Protección de seguridad para niños: impide el encendido por parte de niños de acuerdo a la norma EN13869. Llama estable y altura constante. Fabricado con una **resina técnica (Delrin®)** con resistencia mecánica alta.

DE > Praktisches, handliches Design. Kindersicherung: Verhindert die Feuerzeug-Zündung durch Kinderhände nach EN13869. **Gleichmäßige Flamme** dank reinen Isobutangases. Hergestellt aus **hochentwickeltem Harz (Delrin®)** mit überaus hoher Stabilität.

IT > Formato tascabile. Sistema di sicurezza a prova di bambini: previene l'accensione da parte di bambini ai sensi della normativa EN13869. **Fiamma stabile** grazie al carburante in puro isobutano. Fatto con una **resina tecnica (Delrin®)** con alta resistenza meccanica.



Scan this page, live the BIC Graphic Augmented Reality experience and share it!

100%

2360 2377 2364

2360 Standard

2377 Pastel

2364 All Black

A/C > SP: max. 4 colours

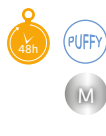

MOQ: 300 u.

300 ± 3,9 Kg

600 ± 7,6 Kg

2360/2364 MADE IN SPAIN

2377 MADE IN FRANCE

Standard Packaging: in tray of 50 u. / barquette 50 u. / en bandeja de 50 u. / 50er Aufsteller / In vassoi da 50 pezzi



BY THE PIONEER
in Digital printing

J25 Digital & J25 Digital Transfer



EN > **New finishes in Digital*:**
Matte, Puffy ink,
Holographic and Metallic.
Impressive results!

FR > **Nouvelles finitions en impression numérique*:**
mate, encre Puffy,
holographique et
métallique. **Des résultats impressionnants !**

ES > **Nuevos acabados en Digital*:** Mate, tinta Puffy, Holográfico y Metálico. **¡Resultados impresionantes!**

DE > **Neue Ausführungen in Digital*:** Matt, Puffy Ink-Tinte, Holographie und Metallic. **Beeindruckende Ergebnisse!**

IT > **Nuove finiture in digitale*:** opaco, inchiostro Puffy, olografico e metallizzato. **Risultati incredibili!**

NEW FINISHES



2368



2369



Scan this page, live the BIC Graphic Augmented Reality experience and share it!

100%

2369

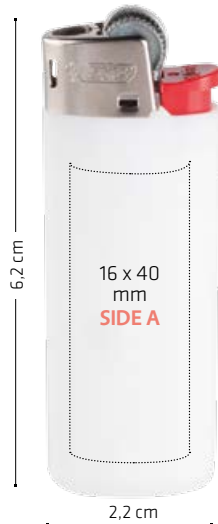

2368



2368 Digital*

A/B/C/D> DG: area for images

2369 Digital Transfer

A> DT: area for images
C> SP: max. 4 colours

2368



2369



MOQ Digital finishes:

Brilliant or Matte	600 u.
Holographic	600 u.
Puffy Ink	5.100 u.
Metallic	50.000 u.
Digital Transfer	300 u.



Standard Packaging: in tray of 50 u. / barquette 50 u. / en bandeja de 50 u. / 50er Aufsteller / In vassoio da 50 pezzi



J23

- EN > Thin and elegant. **Comfortable** to use. **Stable flame** due to pure isobutane fuel. Made of a **technical resin (Delrin®)** with high mechanical resistance.
- FR > Fin et élégant. **Confortable** à l'utilisation. **Flamme stable** grâce à l'isobutane pur. Fabriqué avec de la **resine (Delrin®)** à haute résistance mécanique.
- ES > Fino y elegante. **Cómodo** de usar. Llama estable gracias al combustible puro de isobutano. Hecho de una **resina técnica (Delrin®)** con resistencia mecánica alta.
- DE > Schlank und elegant. **Einfach** in der Handhabung. **Gleichmäßige Flamme** dank reinen Isobutangases. Hergestellt aus **hochentwickeltem Harz (Delrin®)** mit überaus hoher Stabilität.
- IT > Sottile ed elegante. **Comodo** da usare. **Fiamma stabile** grazie al carburante in puro isobutano. Fatto con una **resina tecnica (Delrin®)** con alta resistenza meccanica.



2340
Standard

A/C> SP: max. 4 colours



MOQ: 300 u.



± 4,7 Kg ± 9,3 Kg



Standard Packaging: in tray of 50 u. /
barquette 50 u. / en bandeja de 50 u. /
50er Aufsteller / in vassoio da 50 pezzi



J26

EN > Extra long-lasting: **up to 3.000 lights!**
Gives **up to 2 times more lights than other flint lighters** of the same format (Internal testing - EU Market 2008-2010). Comfortable to use.

FR > Longue durée : **jusqu'à 3 000 allumages.** Donne **2 fois plus d'allumages que les autres briquets à molette** du même format (testé en interne - marché EU 2008-2010). Confortable à l'utilisation.

ES > Extra duración: **hasta 3.000 alumbrados!** Proporciona hasta **el doble de alumbrados que otros encendedores** del mismo formato (pruebas internas - mercado UE 2008-2010). Cómodo de usar.

DE > Extra ausdauernd: **Bis zu 3.000 Zündungen!**
Bis zu **2 mal mehr Zündungen als andere** Reibrad-Feuerzeuge. (Interne Tests im europäischen Markt von 2008-2010). Einfach in der Handhabung.

IT > Durata extra lunga: **sino a 3.000 accensioni!** Produce **sino al doppio delle accensioni rispetto ad altri accendini** dello stesso formato (Test interni - Mercato UE 2008-2010). Comodo da usare.



2320
Standard

A/C> SP: max. 4 colours



MOQ: 300 u.

300 ± 74 Kg
600 ± 151 Kg
MADE IN SPAIN

Standard Packaging: in tray of 50 u. /
barquette 50 u. / en bandeja de 50 u. /
50er Aufsteller / In vassoi da 50 pezzi



J26 Digital



NEW FINISHES

EN > **New finishes in Digital:** Matte, Puffy ink, Holographic and Metallic. **Impressive results!**

FR > **Nouvelles finitions en impression numérique :** mate, encre Puffy, holographique et métallique. **Des résultats impressionnants !**

ES > **Nuevos acabados en Digital:** Mate, tinta Puffy, Holográfico y Metálico. **¡Resultados impresionantes!**

DE > **Neue Ausführungen in Digital:** Matt, Puffy-Tinte, Holographie und Metallic. **Beeindruckende Ergebnisse!**

IT > **Nuove finiture in digitale:** opaco, inchiostro Puffy, olografico e metallico. **Risultati incredibili!**



100%



2328
Digital

A/B/C/D> DG: area for images



MOQ Digital finishes:
Brilliant or Matte.....600 u.
Holographic600 u.
Puffy Ink5.100 u.
Metallic50.000 u.
See details p. 209



Standard Packaging: in tray of 50 u. /
barquette 50 u. / en bandeja de 50 u. /
50er Aufsteller / In vassoi da 50 pezzi



J38

EN > Our bestselling electronic lighter. **Elegant & comfortable lighting** thanks to one-step ignition mechanism.

BY THE EXPERT 
of *Lighters*





J38

FR > Notre briquet électronique champion des ventes !
Allumage élégant et pratique, grâce à son système d'allumage piezo.

ES > El encendedor electrónico más vendido. Encendido **cómodo y elegante**, gracias al mecanismo de ignición de un sólo paso.

DE > Unser meistverkauftes Elektronik-Feuerzeug.
Elegantes und komfortables Zünden dank des einstufigen Zündungsmechanismus.

IT > Il nostro accendino elettronico più venduto.
Azionamento elegante e comodo grazie al meccanismo di accensione a una sola fase.



Scan this page, live the BIC Graphic Augmented Reality experience and share it!

2452

2451

7.9 cm

20 x 50 mm
SIDE A

20 x 50 mm
SIDE C

2.5 cm

2.5 cm

2452
Chrome Hood

2451
Gold Hood

A/C> SP: max. 4 colours

2452

2451



MOQ: 300 u.

300
± 6,6 Kg

600
± 13,2 Kg



Standard Packaging: in tray of 50 u. /
barquette 50 u. / en bandeja de 50 u. /
50er Aufsteller / In vassoi da 50 pezzi



BY THE PIONEER
in Digital printing

J38 Digital



NEW FINISHES

EN > **New finishes in Digital:**
Matte, Puffy ink,
Holographic and Metallic.
Impressive results!

FR > **Nouvelles finitions en impression numérique:**
mate, encre Puffy,
holographique et métallique. **Des résultats impressionnants !**

ES > **Nuevos acabados en Digital:** Mate, tinta Puffy, Holográfico y Metálico. **¡Resultados impresionantes!**

DE > **Neue Ausführungen in Digital:** Matt, Puffy-Tinte, Holographie und Metallic. **Beeindruckende Ergebnisse!**

IT > **Nuove finiture in digitale:**
opaco, inchiostro Puffy,
olografico e metallico.
Risultati incredibili!



Scan this page,
live the BIC Graphic
Augmented Reality
experience and
share it!

100%



BIC® LIGHTERS

2458
Digital

A/B/C/D> DG: area for images



PUFFY

M

H



MOQ Digital finishes:

Brilliant or Matte.....600 u.
Holographic600 u.
Puffy Ink.....5.100 u.
Metallic 50.000 u.
See details p. 209

300
± 6,6 Kg

600
± 13,2 Kg



Standard Packaging: in tray of 50 u. /
barquette 50 u. / en bandeja de 50 u. /
50er Aufsteller / In vassoi da 50 pezzi



J39

- EN > Convenient mini size.
Comfortable lighting, thanks to one-step ignition mechanism.
- FR > Taille mini et pratique.
Allumage pratique grâce à son système piezo.
- ES > Tamaño pequeño adecuado.
Encendido **cómodo y elegante**, gracias al mecanismo de ignición de un sólo paso.
- DE > Praktisches Miniformat.
Komfortables Zünden dank des einstufigen Zündungsmechanismus.
- IT > Pratico formato mini.
Azionamento comodo grazie al meccanismo di accensione a una sola fase.



2479
Chrome Hood

A/C> SP: max. 4 colours



MOQ: 300 u.



± 6 Kg



± 11,1 Kg



Standard Packaging: in tray of 50 u. /
barquette 50 u. / en bandeja de 50 u. /
50er Aufsteller / In vassoio da 50 pezzi



J39 Digital



BY THE PIONEER
in Digital printing

EN > **New finishes in Digital:** Matte, Puffy ink, Holographic and Metallic. **Impressive results!**

FR > **Nouvelles finitions en impression numérique :** mate, encre Puffy, holographique et métallique. **Des résultats impressionnants !**

ES > **Nuevos acabados en Digital:** Mate, tinta Puffy, Holográfico y Metálico. **¡Resultados impresionantes!**

DE > **Neue Ausführungen in Digital:** Matt, Puffy-Tinte, Holographie und Metallic. **Beeindruckende Ergebnisse!**

IT > **Nuove finiture in digitale:** opaco, inchiostro Puffy, olografico e metallico. **Risultati incredibili!**

NEW FINISHES



100%



2481
Digital

A/B/C/D> DG: area for images



MOQ Digital finishes:
 Brilliant or Matte.....600 u.
 Holographic600 u.
 Puffy Ink.....5.100 u.
 Metallic 50.000 u.
 See details p. 209



Standard Packaging: in tray of 50 u. /
 barquette 50 u. / en bandeja de 50 u. /
 50er Aufsteller / In vassoi da 50 pezzi



Enhance your brand with our new finishes and personalisation options!



Digital Brilliant

Digital Matte

NEW FINISHES

Now ALSO available in matte finish!



NEW FINISHES

H

Holographic

✓ **Stand out from the crowd!** Convert your logo into a three-dimensional image **using holograms** in the background or in different parts of the logo. Availability: February 2015

Now ALSO available in matte finish!



NEW FINISHES

PUFFY

Puffy printing

✓ Be original! Highlight your brand with our "Puffy" ink to give a relief effect to your logo.



NEW FINISHES

M

Metallic

✓ Create great effects! **Metallic effects** in texts, images and backgrounds.

Now ALSO available in matte finish!

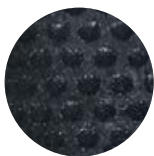

FR > **Donnez vie à votre briquet avec nos nouvelles finitions et options de personnalisation!**
Impression numérique brillante / Impression numérique mate
 Désormais ÉGALEMENT disponible en finition mate!
Holographique
 ✓ **Sortez du lot!** Transformez votre logo en image 3D grâce à des **hologrammes** imprimés à l'arrière-plan ou sur une partie de votre logo. Disponible à compter de février 2015.
Encre «puffy»
 ✓ **Démarquez-vous!** Mettez l'accent sur votre marque avec notre **encre «puffy»**, qui donne du relief à votre logo.
Métallique
 ✓ **Surprenant! Un effet métallique** sur les textes, les images ou l'arrière-plan.

ES > **¡Dale vida a tu encendedor con los nuevos acabados y opciones de personalización!**
Digital brillante / Digital mate
 ¡Ahora TAMBIÉN disponible en acabado mate!
Holográfico
 ✓ **¡Destaca entre la multitud!** Convierte tu logo en una imagen tridimensional **usando hologramas** en el fondo del diseño y/o en algunas partes del logo. Disponible: Febrero 2015
Impresión Puffy
 ✓ **¡Sé único!** Resalta tu marca con nuestra **tinta "Puffy"** dándole un efecto de relieve a tu logo.
Metallico
 ✓ **¡Crea efectos estupendos!**
Efectos metálicos en los textos, imágenes o fondos del diseño.

DE > **Verleihen Sie Ihrem Feuerzeug neues Leben mit neuen Ausführungs- und Personalisierungsoptionen!**
Digital Brilliant / Digital Matt
 Nun AUCH in matter Ausführung erhältlich!
Holographie
 ✓ **Heben Sie sich von der Masse ab!** Geben Sie Ihrem Logo ein dreidimensionales Erscheinungsbild **durch Verwendung von Hologrammen** als Hintergrund oder als Bestandteil Ihres Logos. Erhältlich ab Februar 2015.
Puffy Ink
 ✓ **Seien Sie einzigartig!** Stellen Sie Ihre Marke mit unserer **"Puffy"-Tinte**, die Ihrem Logo einen Reliefeffekt verleiht, besonders heraus.
Metallic
 ✓ **Erzielen Sie phantastische Effekte!**
Metallic-Effekte in Texten, Bildern oder Hintergründen

IT > **Dai vita al tuo accendino con nuove finiture e possibilità di personalizzazione!**
Digitale brillante / Digitale opaco
 Adesso disponibile ANCHE con finitura opaca!
Olografico
 ✓ **Fatti notare tra la folla!** Trasforma il tuo logo in un'immagine tridimensionale **utilizzando ologrammi** sullo sfondo o in alcune parti del logo. Disponibilità: febbraio 2015.
Inchiostro Puffy
 ✓ **Sii unico!** Sottolinea il tuo marchio con il nostro **inchiostro "Puffy"** che dona un effetto rilievo al tuo logo.
Metallico
 ✓ **Crea effetti mai visti! Effetti metallici** in testi, immagini o sfondi



Mega Lighter & Mega Lighter *britePix*™

- EN > Curved body shape for **comfortable handling**. Compact and trendy. A retractable **hook for easy storage**. **Visible gas supply**: easy to check gas level.
- FR > Forme plus incurvée du corps pour une **manipulation agréable**. Compact et moderne. **Crochet rétractable pour un rangement facile**. **Alimentation visible du gaz** : facile pour contrôler le niveau de gaz.
- ES > Forma del cuerpo curvada para un **cómodo manejo**. Compacto y moderno. **Gancho plegable para colgarlo con facilidad**. **Suministro de gas visible**: es fácil comprobar el nivel de gas.
- DE > Gewölbter Schaft für **angenehme Handhabung**. Kompakt und modisch. Versenkbarer **Aufhänger für eine einfache Aufbewahrung**. **Gastank sichtbar**: Aktueller Füllstand ist einfach abzulesen.
- IT > Forma del corpo più ricurva per una **comoda maneggevolezza**. Compatto e trendy. **Gancio retraibile per riporlo facilmente**. **Livello del gas visibile**, per un più facile controllo.



Scan this page, live the BIC Graphic Augmented Reality experience and share it!



2500

2501

A/B> PD: max. 2 Colours

B> BP: full colour



2500 Mega Lighter

2501 *britePix*™

2500 / 2501



Conform ISO22702

MOQ: 100 u. ± 703 Kg

Standard packaging: 100 pcs in an export carton in grid / Embalaje estándar: 100 ud por caja en rejilla / 100 Stück im Umkarton mit Rastertrennung / Confezione standard: cartone espositore da 100 pezzi con griglia.



Clip Case *britePix*™

EN > Wide printing surface.

Ideal to attach on the top of your pack of cigarettes!

Full colour on the go!

All cases are delivered with a white BIC® J25 lighter.

FR > Vaste surface d'impression. Idéal pour être fixé sur la partie supérieure d'un paquet de cigarettes !

Les couleurs ont la vedette !

Toutes nos coques sont livrées avec un briquet mini blanc.

ES > Amplia superficie de impresión.

Ideal para fijar en la parte superior de su paquete de cigarrillos!

¡Llévalo a todo color!

Todas las fundas incluyen un encendedor blanco.

DE > Große Aufdruckfläche. Ideal zum Fixieren auf Ihrer Zigarettenschachtel!

Vollfarbe "on the go"!

Alle Hüllen werden mit einem weissen J25 Mini Feuerzeug geliefert.

IT > Vasta area di stampa. Ideale da fissare nella parte superiore del tuo pacchetto di sigarette!

Passa al colore!

Tutti i copri accendini sono venduti con l'accendino bianco.



2398 *britePix*™

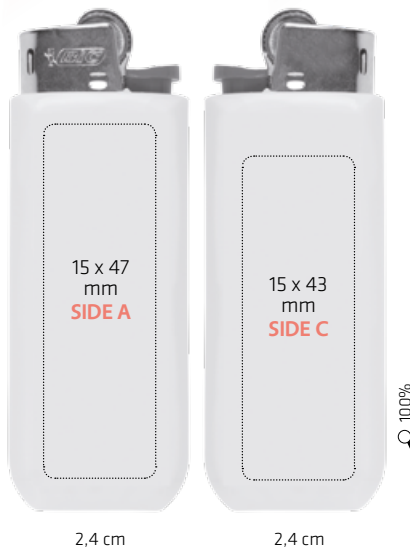

2398 *britePix*™

A/C> BP: full colour

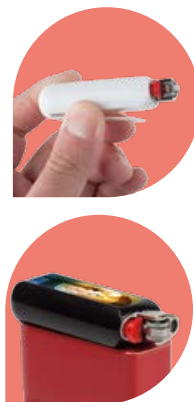

BIC® LIGHTERS

Colours



MOQ: 100 u. ± 75 Kg 300 MADE IN SPAIN

Standard packaging: Box of 50 / Boîte de 50 / Caja de 50 / Box mit 50 Stück / Confezione da 50



Styl'it Fashion & Styl'it Fashion *britePix*™

EN > **Trendy**, hard plastic case. All cases are delivered with a white BIC® J25 lighter.

FR > Étui **tendance** en plastique rigide. Toutes nos coques sont livrées avec un briquet mini blanc.

ES > **Moderna** funda de plástico rígido. Todas las fundas incluyen un encendedor blanco.

DE > **Trendige** Hülle aus hartem Kunststoff. Alle Hüllen werden mit einem weissen J25 Mini Feuerzeug geliefert.

IT > Di plastica resistente e **alla moda**. Tutti i copri accendini sono venduti con l'accendino bianco.



2390

2399 *britePix*™

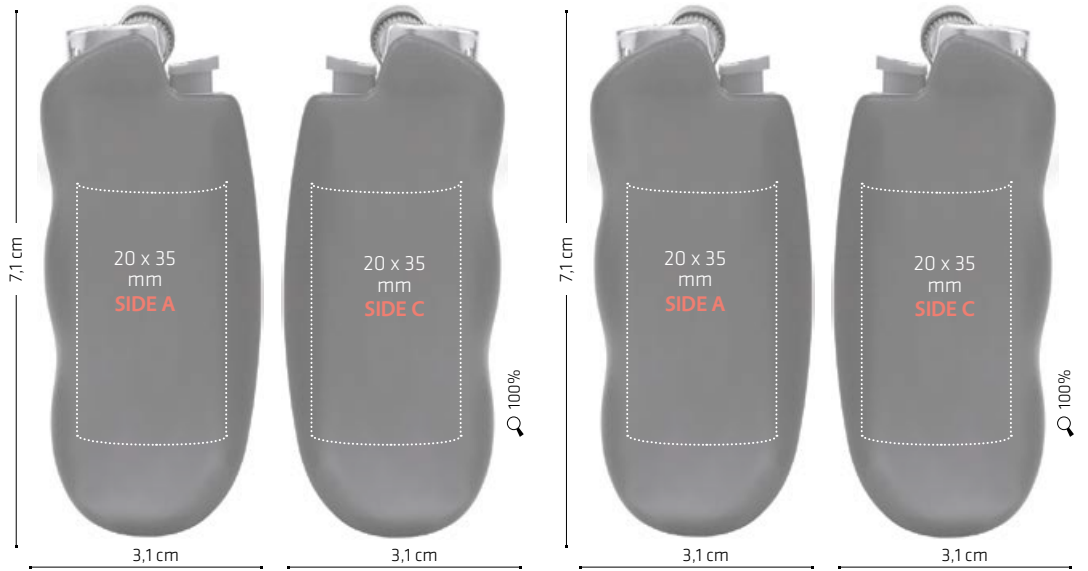

2390
Styl'it Fashion

A/C> SP: max. 1 colour

2399
britePix™

A/C> BP: full colour



66

67



MOQ: 100 u. ± 8,4 Kg



Standard packaging: Box of 50 / Boîte de 50 / Caja de 50 / Box mit 50 Stück / Confezione da 50



Styl'it Luxury

EN > **Premium** metal design. All cases are delivered with a white BIC® J25 lighter.

FR > Aspect métal **haut de gamme**. Toutes nos coques sont livrées avec un briquet mini blanc.

ES > Diseño **premium** de metal. Todas las fundas incluyen un encendedor blanco.

DE > Hochwertige Premium-Metallhülle, **der Klassiker**. Alle Hüllen werden mit einem weissen J25 Mini Feuerzeug geliefert.

IT > In metallo e con design **premium**. Tutti i copri accendini sono venduti con l'accendino bianco.



100%



100%

2381
BIC® Styl'it Luxury

A/C> PD: max.
4 colours

A/C> LE

BIC® LIGHTERS

2381



01

47



MOQ: 100 u.

300
± 6.1 Kg



Standard Packaging: in tray of 50 u. /
barquette 50 u. / en bandeja de 50 u. /
50er Aufsteller / In vassoi da 50 pezzi

Packaging

BIC® Special Packaging:

Black Two-Piece Gift Box	219
Black Velvet Pouch	218
Carton Black & Silver colour gift box	218
Cello Wrap	216
Frosted Pouch	217
Hinged Gift Box	220
Media Pack	217
See-Through Gift Box	220
Tube	217

Sheaffer® Special Packaging:

Sheaffer® Large Optional Packaging	221
Sheaffer® Luxury Gift Box	221
Sheaffer® Premium Gift Box	221
Sheaffer® Small Optional Packaging	221
Sheaffer® Standard Gift Box	221



Packaging



Cello Wrap
20001: 1 product
20002: 2 products
20003: 3 products
20004: 4 products

- EN > Not available for graphite pencils or metal pens.
Due to different printing processes, the imprint colours on pens and notepads may differ very slightly.
- FR > Non disponible pour crayons et Stylos métallisés.
Du fait des différents procédés d'impression utilisés, les couleurs de marquage peuvent différer légèrement.
- ES > No disponible para lápices ni bolígrafos metálicos.
Debido al uso de diferentes procesos de impresión, los colores de los bolígrafos y los blocks de notas pueden variar ligeramente.
- DE > Nicht erhältlich für Bleistifte oder Metallkugelschreiber.
Aufgrund unterschiedlicher Drucktechniken, können die Druckfarben auf den Schreibgeräten und auf den Haftnotizen leicht voneinander abweichen.
- IT > Non disponibile per matite né per Penne metalliche.
A causa delle differenti tecniche di stampa lo stesso colore stampato su penna e blocchetto potrebbe risultare leggermente diverso.



00051
Frosted Pouch for 1 or 2 items



00049
Media Pack*



36001
Tube for 1 item

EN > Available for 1 or 2 (slim) BIC® writing instruments except: graphite pencils, BIC® Media Clic Grip, BIC® Matic® Grip and BIC® Clic Matic.

FR > Disponible pour 1 ou 2 articles (fins) d'écriture BIC®, à l'exception des crayons à papier, BIC® Media Clic Grip, BIC® Matic® Grip et BIC® Clic Matic.

ES > Disponible para 1 ó 2 (finos) instrumentos de escritura BIC® excepto lápices, BIC® Media Clic Grip, BIC® Matic® Grip y BIC® Clic Matic.

DE > Erhältlich für eines oder zwei schlanke BIC® Schreibgeräte mit Ausnahme von Graphit-Bleistiften, BIC® Media Clic Grip, BIC® Matic® Grip und BIC® Clic Matic.

IT > Disponibile per 1 o 2 strumenti da scrittura sottili BIC® eccetto matite, BIC® Media Clic Grip, BIC® Matic® Grip e BIC® Clic Matic.

EN > Developed for 2 BIC® Media Max or 3 BIC® Media Clic. Available for all BIC® writing instruments except graphite pencils.
*While stock lasts

FR > Développé pour 2 BIC® Media Max ou 3 BIC® Media Clic. Disponible pour tous les articles d'écriture BIC® sauf les crayons à papier.
*Jusqu'à épuisement des stocks

ES > Desarrollado para 2 BIC® Media Max ó 3 BIC® Media Clic. Disponible para todos los instrumentos de escritura BIC® excepto lápices.
*Hasta fin de existencias

DE > Für zwei BIC® Media Max oder drei BIC® Media Clic geeignet. Erhältlich für alle BIC® Schreibgeräte mit Ausnahme von Graphit-Bleistiften.
*Solange der Vorrat reicht

IT > Appositamente studiato per 2 BIC® Media Max o 3 BIC® Media Clic. Disponibile per tutti i tipi di penna BIC® eccetto matite.
*Fino ad esaurimento stock

EN > Available for all writing instruments, except: BIC® Pivo® Metal, BIC® Tri-Tone Twist, BIC® Protrusion Grip.

FR > Disponible pour tous les instruments d'écriture sauf: BIC® Pivo® Metal, BIC® Tri-Tone Twist, BIC® Protrusion Grip.

ES > Disponible para todos los instrumentos de escritura excepto: BIC® Pivo® Metal, BIC® Tri-Tone Twist, BIC® Protrusion Grip.

DE > Erhältlich für alle Schreibgeräte, ausgenommen: BIC® Pivo® Metal, BIC® Tri-Tone Twist, BIC® Protrusion Grip.

IT > Disponibile per tutti i prodotti da scrittura ad eccezione di: BIC® Pivo® Metal, BIC® Tri-Tone Twist, BIC® Protrusion Grip.



00039
Black Velvet Pouch for 1 item

00050
Black Velvet Pouch for 2 items

00062
Carton Black & Silver colour gift box*

EN > Available for all writing instruments, except graphite pencils.

FR > Disponible pour tous les articles d'écriture, à l'exception des crayons à papier.

ES > Disponible para todos los productos de escritura excepto lápices.

DE > Erhältlich für alle Schreibgeräte außer Bleistifte.

IT > Disponibile per tutti gli strumenti da scrittura eccetto matite.

EN > *While stock lasts

FR > *Jusqu'à épuisement des stocks

ES > *Hasta fin de existencias

DE > *Solange der Vorrat reicht

IT > *Fino ad esaurimento stock



00063
Black Two-Piece Gift Box for 1 item

00064
Black Two-Piece Gift Box for 2 items

EN > Available for all writing instruments, except graphite pencils.

FR > Disponible pour tous les articles d'écriture, à l'exception des crayons à papier.

ES > Disponible para todos los productos de escritura excepto lápices.

DE > Erhältlich für alle Schreibgeräte außer Bleistifte.

IT > Disponibile per tutti gli strumenti da scrittura eccetto matite.

Packaging



70%

30%

A > SP: max. 1 colour
 B > BP: full colour

00065
 Hinged Gift Box for 1 or 2 items



00066
 See-through Gift Box for 1 or 2 items

- EN > Available for all writing instruments, except graphite pencils.
- FR > Disponible pour tous les articles d'écriture, à l'exception des crayons à papier.
- ES > Disponible para todos los productos de escritura excepto lápices.
- DE > Erhältlich für alle Schreibgeräte außer Bleistifte.
- IT > Disponibile per tutti gli strumenti da scrittura eccetto matite.

SHEAFFER® Packaging



730050
Sheaffer® Premium Gift Box*



730010
Sheaffer® Large Optional Packaging*



730046
Sheaffer® Luxury Gift Box*



730049, 730051
Sheaffer® Standard Gift Box



730048
Sheaffer® Small Optional Packaging*

730049, 730051
Sheaffer® Standard Gift Box
Standard:
Sheaffer® 100
Sheaffer® Stylus
Sheaffer® VFM

730050
Sheaffer® Premium Gift Box*
Standard:
Sheaffer® Legacy® Heritage
Sheaffer® Taranis®

730046
Sheaffer® Luxury Gift Box*
Standard:
Sheaffer® 300
Sheaffer® 500
Sheaffer® Intensity
Sheaffer® Prelude®
Sheaffer® Prelude® Mini
Sheaffer® Sagaris®

*EN > Optional premium gift packaging for all Sheaffer® Collections.

*FR > Optionnel pour les autres modèles Sheaffer®.

*ES > Estuche opcional de alta calidad para toda la colección Sheaffer®.

*DE > Optionale Premium-Geschenkverpackung für alle Sheaffer®-Kollektionen.

*IT > Confezione regalo premium disponibile su richiesta su tutta la gamma Sheaffer®.

General Information	224
BIC® Sticky Note™ Information	226
Product Index	228

 **General Information**

General Information

File Information

Required files:

- Electronic file with the graphic design (artwork).
- Separate file for the text. For individual laser engraving please provide texts only in Excel® format (.xls)

Artwork Features

Please submit your artwork in one of the following formats:

- JPG / 300 dpi not compressed (only for images, no texts)
- PDF / outlined
- Illustrator® CC / outlined
- Photoshop® CC / with layers
- ZIP files

In order to facilitate a fluid order process and obtain an appropriate final result, it is important to provide us the information in one of the above listed formats. Should the customer's design not fit into our imprint area, we will modify it accordingly.

Typefaces:

- All the typefaces must be converted to an artwork. Verify the minimum type sizes & line weights. Please, contact Customer Service for further information.

Special for Writing Products

Available imprint area depends on required printing technique.

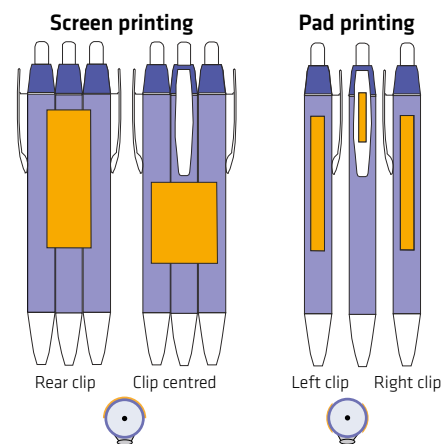

Special for Digital Lighters (J25, J26, J38 & J39)

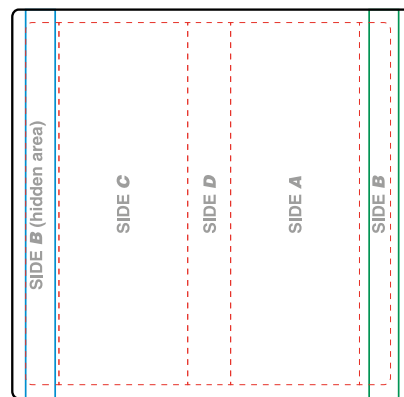

FR > Informations générales

Informations concernant les fichiers

Fichiers à fournir :

- un fichier électronique avec le dessin graphique
 - et un fichier différent pour le texte.
- Pour un marquage au laser individuel, les textes devront être fournis uniquement sous format Excel® (.xls).

Propriétés du matériel graphique

Envoyez-nous votre matériel graphique dans un des types de fichiers suivants :

- JPG / 300 dpi sans compresser à la taille réelle de marquage (seulement images, sans texte)
- PDF / vectorisé
- Illustrator® CC / vectorisé
- Photoshop® CC / avec les couches
- Fichiers ZIP

Il est important que vous nous fassiez parvenir les informations dans l'un de ces formats afin de traiter au mieux votre commande et d'obtenir un résultat final optimal.

Si la création du client ne rentre pas dans notre format, nous modifierons en conséquence.

Type de caractères:

- Tous les types de caractères doivent être convertis en image. Vérifiez les tailles minimales des types et les épaisseurs de trait. Veuillez contacter le service clientèle pour plus d'informations.

Spécial pour les produits d'écriture

La zone d'impression disponible dépend de la technique d'impression requise.

Spécial pour les briquets (J25, J26, J38 et J39)

ES > Información general

Información sobre archivos

En cualquier caso, los archivos deben ser dos:

- un archivo electrónico con el diseño gráfico (creatividad)
 - y otro archivo distinto para el texto.
- Para un grabado en láser, facilite los textos únicamente en formato Excel® (.xls).

Propiedades del material gráfico

Envíenos su material gráfico en alguno de los siguientes tipos de archivo:

- JPG / 300 dpi sin comprimir al tamaño real de impresión (sólo imágenes, sin texto)
- PDF / vectorizado
- Illustrator® CC / vectorizado
- Photoshop® CC / con capas
- Archivos ZIP

Es importante que nos proporcione la información en uno de estos formatos para agilizar su pedido y para obtener un resultado final adecuado.

Si el diseño del cliente no encaja correctamente en el área de impresión, lo modificaremos consecuentemente.

Fuentes:

- Todos los tipos de letra se deben convertir en un arte final. Verifique los tamaños de los tipos mínimos y grosos de línea.

Por favor, contacte con Atención al Cliente para más información.

Especial para Instrumentos de Escritura

Área de impresión disponible según la técnica de impresión.

Especial para encendedores en digital (J25, J26, J38 & J39)

DE > Allgemeine Information

Druckvorlageanforderungen

Bitte senden Sie uns folgende Dateien:

- reprofähige Druckvorlagen als Grafik
- Separate Textdatei.

Für personalisierte Lasergravuren müssen die Texte in Excel®-Format (.xls) eingeschickt werden.

Technische Daten der Grafikdateien

Bitte schicken Sie Ihre Grafiken in einem dieser Formate:

- JPG / 300 dpi nicht komprimiert und in der tatsächlichen Druckgröße (nur Bilddaten, kein Text)
- PDF / Vektordatei
- Illustrator® CC / Vektordatei
- Photoshop® CC / mit Ebenen
- ZIP format

Wir bitten um Zusendung der Daten in den angegebenen Formaten. Damit können wir den Auftrag schnellstmöglich bearbeiten und ein optimales Druckergebnis erreichen. Sofern der Entwurf des Kunden nicht in unseren Druckbereich passt, werden wir ihn entsprechend anpassen.

Schriftarten:

- Alle Schriftarten müssen in eine Vorlage umgewandelt werden. Überprüfen Sie die Mindestschriftgrößen und Linienstärken.

Für weitere Informationen kontaktieren Sie bitte unseren Kundenservice

Speziell für Schreibprodukte

Die mögliche Werbeaufdruckfläche ist von der angeforderten Drucktechnik abhängig.

Speziell für digitale Feuerzeuge (J25, J26, J38 und J39)

IT > Informazioni Generali

Informazione sui file

Sempre, per quanto riguarda i file, i documenti si devono inviare come di seguito:

- un file elettronico con il design grafico (creatività)
 - ed un altro file separato per il testo.
- Per un'incisione a laser singola, consegnare i testi esclusivamente in formato Excel® (.xls).

Proprietà del materiale grafico

Inviatoci il vostro materiale grafico in uno dei seguenti tipi di file:

- JPG / 300 dpi non compresso e nel formato reale della stampa (solo per le immagini, non per il testo)
- PDF / vettorializzato
- Illustrator® CC / vettorializzato
- Photoshop® CC / con livelli
- file ZIP

E' importante che le informazioni vengano mandate in uno dei formati indicati al fine di sveltire l'ordine ed ottenere un miglior risultato finale.

Nel caso in cui il design del cliente non si adattasse all'area di stampa, verrà adattato di conseguenza.

Caratteri:











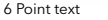

- Tutti i caratteri devono essere convertiti in illustrazione. Verificare le dimensioni minime del carattere e gli spessori del tratto.













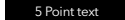

Speciale per prodotti di scrittura





L'area di stampa disponibile dipende dalla tecnica desiderata.

Speciale per accendini digitali (J25, J26, J38 & J39)

Technical Parameters for each Type of Printing

	SCREEN PRINTING/ PAD PRINTING	HOT STAMPING / DEBOSSING	LASER ENGRAVING
Minimum positive text	6 pt (2.1 mm) 	10 pt (3.5 mm) 	6 pt (2.1 mm) 
Minimum negative text	9 pt (3.1 mm) 	15 pt (5.25 mm) 	NOT RECOMMENDED
Minimum thickness for positive lines	0.4 pt (0.14 mm) 	1.5 pt (0.5 mm) 	0.3 pt (0.1 mm) 
Minimum thickness for negative lines	1 pt (0.35 mm) 	1.5 pt (0.5 mm) 	0.5 pt (0.17 mm) 
Minimum thickness for half tones	1.5 pt (0.5 mm) 	NOT POSSIBLE	NOT POSSIBLE
Percentage half tone	50% 		

	STICKY NOTE™	DIGITAL / DIGITAL TRANSFER
Minimum positive text	4 pt (1.4 mm) 	4 pt (1.4 mm) 
Minimum negative text	5 pt (1.75 mm) 	7 pt (2.4 mm) 
Minimum text for half tone	7 pt (2.4 mm) 	1.5 pt (0.5 mm) 
Minimum thickness for positive lines	0.3 pt (0.1 mm) 	0.25 pt (0.08 mm) 
Minimum thickness for negative lines	0.5 pt (0.17 mm) 	0.5 pt (0.17 mm) 
Minimum thickness for lines in half tone	0.5 pt (0.17 mm) 	0.5 pt (0.17 mm) 
Minimum half tone values	C: 5% / M: 5% / Y: 15% / K: 5% 	C: 8% / M: 8% / Y: 12% / K: 8% 

	britePix™
Minimum positive text	6 pt (2.1 mm) 
Minimum negative text	7 pt (2.4 mm) 
Minimum thickness for positive lines	0.4 pt (0.14 mm) 
Minimum thickness for negative lines	0.5 pt (0.17 mm) 
Minimum thickness for half tones	1 pt (0.35 mm) 
Percentage half tone	

Special Imprint Colours

Notebooks

Hot-stamping colours

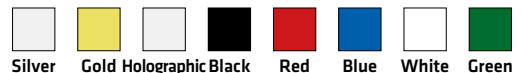

Exact colours with white underlayer requirement

- There are some colour references that need a white underlayer when we print on dark surfaces (Black, Dark blue, Red) in order to get the result required by the customer.
- In case the product only allows 1 imprint, the Customer Service representative will inform the customer that the final imprinted colour will be approximate.
 - In case the product allows an additional imprint, the Customer Service representative will offer the customer the possibility to obtain the exact colour WITH a white underlayer (at extra cost) or to obtain an approximate colour WITHOUT white base.

FR > Paramètres techniques pour chacun des types d'impression

SERIGRAPHIE / TAMPOGRAPHIE
ESTAMPAGE / EMBOSSAGE
LASER
STICKY NOTE™
DIGITAL / TRANSFERT DIGITAL
britePix™
 Texte positif minimum
 Texte négatif minimum
 Épaisseur minimale des lignes positives
 Épaisseur minimale des lignes négatives
 Épaisseur minimale des demi-teintes
 Pourcentage de demi-teinte
 Valeur minimale de demi-teinte
Couleurs spéciales d'impression
Notebooks
 Couleurs d'estampage à chaud
Couleurs exactes qui requièrent une couche de fond blanche
 Plusieurs références de couleur requièrent une couche de fond blanche lorsqu'elles sont imprimées sur des surfaces foncées (noir, bleu foncé, rouge) pour pouvoir obtenir le résultat souhaité par le client.
 • Si le produit permet seulement 1 impression, le représentant du service clients devra prévenir le client que le résultat de la couleur imprimée sera approximatif.
 • Si le produit permet une impression supplémentaire, le représentant du service clients offrira au client la possibilité d'obtenir la couleur exacte AVEC une couche de fond blanche (moyennant majoration du prix) ou d'obtenir une couleur approximative SANS la base blanche.

ES > Parámetros técnicos para cada tipo de impresión

SERIGRAFÍA / TAMPOGRAFÍA
HOTSTAMPING / GRABADO EN RELIEVE
LÁSER
STICKY NOTE™
DIGITAL / TRANSFERENCIA DIGITAL
britePix™
 Texto mínimo positivo
 Texto mínimo negativo
 Grosor mínimo para líneas positivas
 Grosor mínimo para líneas negativas
 Grosor mínimo de marca de agua
 Porcentajes de marca de agua
 Valores mínimos de marca de agua
Impresión de colores especiales
Notebooks
 Colores para Hot-stamping
Colores exactos que requieren una pasada de blanco debajo
 Hay varias referencias de colores que necesitan una pasada de blanco debajo cuando son impresos sobre superficies oscuras (negro, azul oscuro, rojo) para obtener el resultado que requiere el cliente.
 • En caso que el producto solo admita 1 color de marcado, el representante de atención al cliente informará al cliente de que el resultado será aproximado.
 • En caso que el producto permita una pasada más, el representante de atención al cliente ofrecerá al cliente la posibilidad de obtener el color exacto imprimiendo una pasada de blanco (con extra coste) u obtener un color aproximado sin la base blanca debajo.

DE > Technische Parameter für jeden Typendruck

SIEBDRUCK / TAMPONDRUCK
HOTSTAMPING / PRÄGUNG
LASERGRAVUR
STICKY NOTE™
DIGITAL / DIGITALDRUCK
britePix™
 Minimum positiver Text
 Minimum negativer Text
 Mindeststärke für Linien im Positivdruck
 Mindeststärke für Linien im Negativdruck
 Mindeststärke für Halbtöne
 Prozentsatz Halbtöne
 Mindestwerte für Halbtöne
Spezielle Werbeaufdruckfarben
Notebooks
 Farben für Heißprägung
Farbgetreue Farben, für die ein weißer Untergrund erforderlich ist
 Es gibt verschiedene Farbreferenzen, für die ein weißer Untergrund erforderlich ist, wenn auf dunklen Flächen gedruckt werden soll (schwarz, dunkelblau, rot), um das vom Kunden gewünschte Resultat zu erzielen:
 • Falls für das Produkt nur ein Aufdruck möglich ist, wird ein Mitarbeiter des Kundendienstes den Kunden darüber informieren, dass die aufgedruckte Farbe nur annähernd dem gewünschten Farbton entspricht.
 • Ist für das Produkt ein zusätzlicher Aufdruck möglich, wird der Kundendienstmitarbeiter dem Kunden das Angebot machen, die gewünschte Farbe (gegen Aufpreis) im exakt gewünschten Farbton durch Aufbringung eines weißen Untergrundes zu erreichen. Alternativ wird ohne weißen Untergrund eine Farbe erreicht, die dem gewünschten Farbton eventuell nur annähernd entspricht.

IT > Parametri tecnici per ciascun tipo di stampa

SERIGRAFIA / TAMPOGRAFIA
STAMPA A CALDO / BASSORILIEVO
LASER
STICKY NOTE™
DIGITALE / TRASFERIMENTO DIGITALE
britePix™
 Testo positivo minimo
 Testo negativo minimo
 Spessore minimo per linee positive
 Spessore minimo per linee negative
 Spessore minimo per mezzi toni
 Percentuale mezzo tono
 Valori minimi mezzo tono
Colori stampa speciale
Notebooks
 Colori stampa a caldo
Colori precisi con necessità di sfondo bianco
 Alcuni codici di colore richiedono uno sfondo bianco in caso di stampa su superfici scure (nero, blu scuro, rosso) in modo da ottenere il risultato desiderato.
 • Se il prodotto consente solo 1 stampa, il referente del servizio clienti informerà che il colore finale della stampa potrebbe essere leggermente diverso.
 • Se il prodotto consente un'ulteriore stampa, il referente del servizio clienti offrirà la possibilità di ottenere il colore esatto CON uno sfondo bianco (con un supplemento di prezzo) o di accontentarsi di un colore non esattamente coincidente SENZA la base bianca.

BIC® Sticky Note™ Information

BIC® Sticky Note™

Due to the nature of BIC® Sticky Note™ paper, resulting imprints will appear as matte, without shine. The reference colours chosen must be selected from the "PANTONE U" Guide. BIC® Sticky Note™ are printed using a 4-colour process (CMYK), a technique which adjusts the imprint colour to match the references in the "PANTONE U" Guide. As such, the

resulting imprint may differ slightly from the selected Pantone reference. If a direct Pantone is desired a fifth colour may be chosen from the aforementioned Guide for an additional charge. For more information on achieving the closest colour match for imprints on different products within our catalogue please contact our Customer Service Department.



FR > Informations BIC® Sticky Note™ BIC® Sticky Note™

En raison de la nature du papier BIC® Sticky Note™, les résultats à l'impression auront un aspect mat, et non brillant. Les couleurs de référence choisies doivent être sélectionnées dans le guide « PANTONE U ». Les BIC® Sticky Note™ sont imprimés en quadrichromie (CMJN), une technique qui ajuste la couleur d'impression afin de correspondre aux références du guide « PANTONE U ».

Pour toute demande de couleur directe Pantone, nous pouvons proposer une impression avec une 5e couleur de ce Guide, à un prix majoré. Pour plus d'informations sur la manière d'obtenir la couleur correspondante la plus proche pour des impressions sur différents produits de notre catalogue, veuillez contacter notre service client.

ES > BIC® Sticky Note™ Información BIC® Sticky Note™

Debido a la naturaleza del papel para BIC® Sticky Note™ el resultado impreso será mate, nunca brillo. Los colores de referencia solicitados deben ser de la Guía "PANTONE U". El proceso de impresión para BIC® Sticky Note™ es en cuatricromía (CMYK), y el resultado impreso puede variar de la referencia pantone solicitada.

En el caso de querer un Pantone directo, podemos ofrecer la impresión con un 5º color de dicha Guía. Para una mejor coincidencia de color entre los diferentes productos de nuestro catálogo, póngase en contacto con nuestro departamento de Atención al Cliente.

DE > Information BIC® Sticky Note™ BIC® Sticky Note™

Aufgrund der Papier-Beschaffenheit der BIC® Sticky Note™, fällt das Druckergebnis matt aus. Die gewünschten Farbreferenzen wählen Sie aus der "PANTONE U" Farbpalette aus. BIC® Sticky Note™ werden im Offset-Druck nach Euroskala (CMYK) bedruckt. Dank dieser Technik wird das Farbergebnis an die gewünschten Pantone-Referenzen angenähert. Wenn Sie ausdrücklich eine Pantone-Farbe wünschen, können Sie zusätzlich eine fünfte Farbe aus unserem verfügbaren Repertoire auswählen. Hierfür wird ein Aufpreis berechnet. Weitere Informationen zur Farbgleichung bei Bestellung verschiedener Produkte erhalten Sie von Ihrem Customer Service.

IT > Informazioni BIC® Sticky Note™ BIC® Sticky Note™

Data la natura della carta usata per BIC® Sticky Note™ il risultato di stampa sarà opaco, mai brillante. I colori di riferimento richiesti dovranno provenire dalla guida "Pantone U". Il processo di stampa di BIC® Sticky Note™ è la quadricromia (CMYK) ed il risultato può variare rispetto al colore di riferimento richiesto.

Se si desidera un Pantone preciso, potrebbe essere scelto un quinto colore dalla suddetta guida a un costo aggiuntivo.

Per maggiori informazioni sulla migliore corrispondenza del colore di stampa per i vari prodotti del nostro catalogo, contattare il nostro Servizio Clienti.

Imprinting area

Despite the fact that it's possible to print on the upper part of the pad (the adhesive area) we can only print up to 60% colour in this area. Apart from the adhesive area, we recommend only printing 30% of the print area of the product to leave space for note taking and avoid poor ink absorption.

Die cut special shapes and other customisations

Be the most original! Request your BIC® Sticky Note™ Adhesive pad with your desired custom-made shape or customise with your own logo the backsheet of the pads. Please check the conditions of these special customisations with your usual contact person.

Shadow

Shadows or phantom imprints are available at no extra charge. Photographs, line drawings and large logos that cover most of the space at the centre look best.

As they are very light, text and phone numbers are not recommended as phantoms. The most appealing shades are about 10%.



FR > Zone d'impression

Même si la partie supérieure du bloc de papier peut être imprimée (la partie adhésive), elle peut seulement être imprimée jusqu'à 60 % d'encre totale. Indépendamment de la zone adhésive, nous recommandons d'imprimer uniquement 30 % de la surface du produit afin de laisser de l'espace pour la prise de notes et d'éviter ainsi d'éventuelles problèmes d'adhésion de l'encre sur le papier.

Formes spéciales d'estampage et autres personnalisations

Soyez le plus original ! Demandez vos blocs adhésifs BIC® Sticky Note™ avec votre forme personnalisée ou adaptez-les en incluant votre propre logo sur le verso des blocs. Veuillez vérifier les conditions de ces formules spéciales avec votre contact habituel.

Impression Shadow ou fantôme

Les impressions Shadow ou fantôme sont disponibles sans surcoût. Les photographies, les dessins ou logos de grande taille qui couvrent la majorité de la surface centrale ont un meilleur rendu. Comme ces impressions sont très claires, les textes et numéros de téléphone ne sont pas recommandés en Shadow ou fantôme. Les meilleurs rendus sont obtenus à partir d'images tramées aux environs de 10 %.

ES > Área de impresión

A pesar de que la parte superior del taco de papel se puede imprimir (la parte adhesiva), sólo se puede imprimir hasta un 60% de tinta total. Aparte de la zona adhesiva, recomendamos imprimir únicamente el 30% de la zona correspondiente al taco de papel, a fin de dejar más espacio libre para tomar notas y evitar una absorción incorrecta de la tinta.

Formas especiales y otras personalizaciones

Sé el más original! Solicite sus BIC® Sticky Note™ con la forma deseada o personalice con su propio logo la hoja trasera de los blocs adhesivos. Por favor, consulte las condiciones de estas personalizaciones especiales con su persona de contacto habitual

Impresión "marca de agua"

Podemos ofrecerle "marcas de agua" sin coste adicional alguno. Las fotografías, los dibujos lineales o los logotipos de gran tamaño que cubren la mayor parte del espacio central son las opciones que ofrecen mejores resultados. Puesto que la impresión de "marcas de agua" es muy clara, no se recomienda para números de teléfono o texto. Las mejores "marcas de agua" son aquellas que se imprimen en torno al 10%.

DE > Druckbereich

Obwohl es möglich ist auf dem oberen, dem Haftbereich des BIC® Sticky Note™ zu drucken kann nur bis zu maximal 60% der Druckfarbe aufgebracht werden.

Außerhalb des Haftbereichs sollte maximal 30% der Fläche bedruckt werden, um möglichst viel Platz für Notizen frei zu lassen und das Risiko unvollständiger Aufnahme der Schreibfarbe zu vermeiden.

Speziell gestanzte Formen und andere kundenspezifische Anpassungen

Seien Sie der Originellste! Bestellen Sie Ihre BIC® Sticky Note™ Haftnotizen in der von Ihnen gewünschten Form oder individualisieren Sie die Rückseite der Pads mit Ihrem eigenen Logo. Bitte sprechen Sie über die Möglichkeiten für diese speziellen kundenspezifischen Anpassungen mit Ihrem zuständigen Ansprechpartner.

Shadow-Druck

Flood- und Shadowdruckeffekte sind ohne Aufpreis erhältlich. Fotos, Zeichnungen oder große Logos, die einen Großteil der Grundfläche bedecken, eignen sich dafür am besten. Texte und Telefonnummern sind für Hintergrunddrucke nicht geeignet, da sie zu schwierig zu erkennen sind. Beste Resultate werden mit 10% Rasterung erzielt.

IT > Area di stampa

Anche se la parte superiore del blocchetto si può stampare (la parte adesiva) si raccomanda di non usare quest'area per una stampa a tutto colore.

A parte la zona adesiva, si raccomanda di stampare unicamente il 30% della superficie del prodotto, per lasciare più spazio libero per prendere appunti ed evitare un assorbimento irregolare dell'inchiostro.

Forme speciali fustellate e altre personalizzazioni

Sii il più originale! Richiedi il tuo blocco note adesivo BIC® Sticky Note™ con la forma realizzata su misura per te, oppure personalizza con il tuo logo il lato posteriore del blocco note. Ti invitiamo a verificare le condizioni di queste speciali personalizzazioni con il tuo referente abituale.

Effetto fantasma

Possiamo stampare effetti fantasma o sfumature senza costi aggiuntivi. Le fotografie, i disegni lineari o i logotipi di grandi dimensioni che coprono la maggior parte dello spazio centrale sono le opzioni che danno i migliori risultati. Dal momento che le stampe ad effetto fantasma sono molto chiare, non sono consigliabili per numeri di telefono o testo. Gli effetti fantasma migliori sono quelli che si stampano a circa il 10%.

Product Index

Item Name	Page	Item Name	Page	Item Name	Page
Writing Instruments		BIC® Wide Body™ Mini Digital	70	Ecolutions®	
BIC® 2 in 1 Stylus	87	BIC® Wide Body™ Mini Digital Chrome	70	BIC® Ecolutions® Clic	185
BIC® 4 Colours	82	BIC® XS Finestyle	92	BIC® Ecolutions® Clic Gold	185
BIC® 4 Colours Fashion	86	BIC® XS Finestyle britePix™	92	BIC® Ecolutions® Clic Stic	183
BIC® 4 Colours Mini	84	Sheaffer®		BIC® Ecolutions® Clic Stic Digital	184
BIC® 4 Colours Shine	85	Sheaffer® 100	129	BIC® Ecolutions® Evolution Classic	191
BIC® Atlantis®	77	Sheaffer® 300	126	BIC® Ecolutions® Evolution Colour Connection	193
BIC® Attriant®	112	Sheaffer® 500	127	BIC® Ecolutions® Evolution Digital	192
BIC® Brite Liner® Grip	96	Sheaffer® Classic 4 wheeled carry-on	142	BIC® Ecolutions® Evolution Digital Colour Connection	193
BIC® Brite Liner® Grip XL	97	Sheaffer® Classic Bi-Fold Wallet	134	BIC® Ecolutions® Matic®	194
BIC® Celebrate	80	Sheaffer® Classic Business Backpack	139	BIC® Ecolutions® Media Clic	180
BIC® Citation Ballpen	79	Sheaffer® Classic Business Briefcase	138	BIC® Ecolutions® Media Clic Grip	181
BIC® Clic Matic	105	Sheaffer® Classic Business weekender	143	BIC® Ecolutions® Media Clic Grip Digital	182
BIC® Clic Stic	56	Sheaffer® Classic Junior Padfolio	135	BIC® Ecolutions® Media Max	188
BIC® Clic Stic Antimicrobial	60	Sheaffer® Classic Mini Pad	134	BIC® Ecolutions® Media Max Digital	189
BIC® Clic Stic Digital	59	Sheaffer® Classic Padfolio	135	BIC® Ecolutions® Permanent Marker	190
BIC® Clic Stic Mini Digital	59	Sheaffer® Classic Padfolio	135	BIC® Ecolutions® Round Stic®	179
BIC® Clic Stic Softfeel®	58	Sheaffer® Classic Tablet Holder	136	BIC® Ecolutions® Wide Body™	186
BIC® Ecolutions® Clic	78	Sheaffer® Classic Travel Wallet	137	BIC® Ecolutions® Wide Body™ Digital	187
BIC® Ecolutions® Clic Gold	78	Sheaffer® Classic Travel Bag	141	BIC® Ecolutions® 50 mm x 75 mm Adhesive Notepads	195
BIC® Ecolutions® Evolution Classic	100	Sheaffer® Travel Briefcase	140	BIC® Ecolutions® 68 mm x 75 mm Adhesive Notepads	195
BIC® Ecolutions® Evolution Colour Connection	102	Sheaffer® Intensity®	123	BIC® Ecolutions® 75 mm x 75 mm Adhesive Die Cut Notepads	195
BIC® Ecolutions® Evolution Digital	101	Sheaffer® Legacy® Heritage	116	BIC® Ecolutions® 75 mm x 75 mm Adhesive Notepads	195
BIC® Ecolutions® Evolution Digital Colour Connection	102	Sheaffer® Prelude® Black Laque	120	BIC® Ecolutions® 101 mm x 75 mm Adhesive Notepads	195
BIC® Ecolutions® Permanent Marker	95	Sheaffer® Prelude® Black Laque & Palladium Cap	118	BIC® Ecolutions® 101 mm x 75 mm Alternating Sheet Imprint	195
BIC® Great Erase White Board Marker	93	Sheaffer® Prelude® Brushed Chrome	121	BIC® Ecolutions® 101 mm x 75 mm Adhesive Die Cut Notepads	195
BIC® Grip Roller	89	Sheaffer® Prelude® Brushed Chrome Gold	119	BIC® Ecolutions® 101 mm x 101 mm Adhesive Notepads	195
BIC® Intensity® Clic Gel	91	Sheaffer® Prelude® Mini	122	BIC® Ecolutions® 101 mm x 152 mm Adhesive Notepads	195
BIC® Kids PLASTIDECOR®	98	Sheaffer® Sagaris® Chrome trim	124	BIC® Ecolutions® 101 mm x 152 mm Adhesive Notepads	195
BIC® Kids PLASTIDECOR® britePix™	98	Sheaffer® Sagaris® Gold tone trim	125	BIC® Ecolutions® 101 mm x 101 mm Adhesive Notepads	195
BIC® Mark-it Permanent Marker	94	Sheaffer® Sentinel®	131	BIC® Ecolutions® 101 mm x 152 mm Adhesive Notepads	195
BIC® Matic®	103	Sheaffer® Sentinel® Colours	132	BIC® Ecolutions® 101 mm x 152 mm Adhesive Notepads	195
BIC® Matic® Grip	104	Sheaffer® Stylus	128	BIC® Ecolutions® 101 mm x 152 mm Adhesive Notepads	195
BIC® Matic® Quartz	103	Sheaffer® Taranis®	117	BIC® Ecolutions® 101 mm x 152 mm Adhesive Notepads	195
BIC® Media Clic	50	Sheaffer® VFM	130		
BIC® Media Clic Grip	53	Sticky Note™		Lighters & Cases	
BIC® Media Clic Grip Digital	54	BIC® 50 mm x 75 mm Adhesive Notepads	146	BIC® Clip Case britePix™	211
BIC® Media Clic Premium	52	BIC® 68 mm x 75 mm Adhesive Notepads	147	BIC® J23	201
BIC® Media Max	72	BIC® 75 mm x 75 mm Adhesive Die Cut Notepads	149	BIC® J25	198
BIC® Media Max Digital	74	BIC® 75 mm x 75 mm Adhesive Notepad with Flag Booklet	160	BIC® J25 Digital & Digital Transfer	200
BIC® Media Max Premium	75	BIC® 75 mm x 75 mm Adhesive Notepad with Booklet	160	BIC® J26	202
BIC® Media Max Premium Digital	76	BIC® 75 mm x 127 mm Non-Adhesive Scratch Pad	166	BIC® J26 Digital	203
BIC® Pivo® Metal	107	BIC® 96 mm x 152 mm Non-Adhesive Scratch Pad	167	BIC® J38	204
BIC® Protrusion Grip	111	BIC® 101 mm x 75 mm Adhesive Die Cut Notepads	153	BIC® J38 Digital	206
BIC® Rondo Style Classic	110	BIC® 101 mm x 75 mm Adhesive Notepad	150	BIC® J39	207
BIC® Rondo Style Rubberised	110	BIC® 101 mm x 75 mm Alternating Sheet Imprint	152	BIC® J39 Digital	208
BIC® Round Stic®	46	BIC® 101 mm x 75 mm Booklet	159	BIC® Mega Lighter & BIC® Mega Lighter britePix™	210
BIC® Round Stic® Antimicrobial	60	BIC® 101 mm x 75 mm Mini Pencil Booklet	161	BIC® Styl'it Fashion & BIC® Styl'it Fashion britePix™	212
BIC® Round Stic® Digital	48	BIC® 101 mm x 75 mm Adhesive Notepads	154	BIC® Styl'it Luxury	213
BIC® Slim Metal	106	BIC® 101 mm x 101 mm Adhesive Notepads	154		
BIC® Style	44	BIC® 101 mm x 152 mm Adhesive Notepads	155	Packaging	
BIC® Style Clear	45	BIC® 150 mm x 150 mm Booklet Organiser	164	Black Two-Piece Gift Box for 1 item	219
BIC® Super Clip	62	BIC® 150 mm x 150 mm Booklet with Pen Loop	165	Black Two-Piece Gift Box for 2 items	219
BIC® Super Clip britePix™	64	BIC® Clic Stic Mini Organiser	162	Black Velvet Pouch	218
BIC® Super Clip britePix™ Digital	65	BIC® Digital Clic Stic Mini Organiser	163	Carton Black & Silver colour gift box	218
BIC® Super Clip Digital	65	BIC® Ecolutions® Sticky Note™	195	Cello Wrap	216
BIC® Tri-Tone Twist	113	BIC® Flag Booklet	157	Frosted Pouch	217
BIC® Triumph 537R	88	Notebooks		Hinged Gift Box	220
BIC® Velocity® Gel	90	BIC® Notebooks Chipboard Cover	174	Media Pack	217
BIC® Wide Body™	66	BIC® Notebooks Chipboard Cover britePix™	175	See-through Gift Box	220
BIC® Wide Body™ Chrome	69	BIC® Notebooks Plastic Cover	170	Tube	217
BIC® Wide Body™ Digital	71	BIC® Notebooks Plastic Cover britePix™	171	Sheaffer® Large Optional Packaging	221
BIC® Wide Body™ Digital Chrome	71	BIC® Notebooks Plastic Cover Fashion Colours	172	Sheaffer® Luxury Gift Box	221
BIC® Wide Body™ Grip	68	BIC® Notebooks Plastic Cover Fashion Colours britePix™	173	Sheaffer® Premium Gift Box	221
BIC® Wide Body™ Metal	108			Sheaffer® Small Optional Packaging	221
BIC® Wide Body™ Metal Grip	109			Sheaffer® Standard Gift Box	221

Colour table

Nuancier de couleurs / Gama de colores / Farbindex / Tavolozza dei colori

01	blanc blanco weiss bianco	57	blanc opaque blanco opaco opak weiss bianco opaco	51	transparent transparente transparentweiss trasparente	69	blanc glacé blanco frosted gefrostet weiss bianco frosted	3C	blanc perlé blanco perla perlweiß bianco perla
12	jaune amarillo opak gelb giallo	8G	jaune light amarillo light hellgelb giallo chiaro	63	jaune frost amarillo frosted gefrostet gelb giallo frosted	71	orange glacé naranja frosted gefrostet orange arancio frosted	92	orange clear naranja clear transparentorange arancio trasparente
8D	jaune pastel amarillo pastel pastelgelb giallo pastello	10	orange naranja opak orange arancio	03	rouge rojo opak rot rosso	55	rouge laqué rojo lacado rotlackiert smalto rosso	66	rouge glacé rojo frosted gefrostet rot rosso frosted
87	rouge clear rojo clear transparentrot rosso trasparente	08	bordeaux burdeos burgunderrot bordeaux	14	rose rosa rosa rosa	5C	magenta fucsia pink fucsia	95	rose clair rosa clear transparentrosa rosa trasparente
2C	rose métallisé rosa metálico metallcink rosa metallizzato	26	or oro gold oro	4B	violet glacé violeta frosted gefrostet violet viola frosted	2D	lilas violeta lila viola	84	pourpre pastel púrpura pastel pastellila viola pastello
93	pourpre clair púrpura clear transparentlila viola trasparente	39	pourpre glacé púrpura frosted gefrostet lila viola frosted	13	pourpre púrpura opak lila viola	7G	violet métallisé violeta metálico metallcila viola metallizzato	3D	bleu caraïbe azul caribeño karibikblau azzurro caraibico
24	bleu clair azul claro hellblau azzurro chiaro	67	bleu glacé azul frosted gefrostet blau azzurro frosted	86	bleu clair azul clear transparentblau azzurro trasparente	83	bleu pastel azul pastel pastelblau azzurro pastello	34	bleu métallique azul metálico metallcblau blu metallizzato
1D	bleu foncé métallisé azul metálico oscuro metallc Dunkelblau blu scuro metallizzato	04	bleu azul opak blau blu	40	bleu nuit glacé azul oscuro frosted gefrostet dunkelblau blu frosted	89	bleu marine clair azul oscuro clear transparentdunkelblau blu trasparente	50	bleu royal azul real königsblau blu royal
07	bleu marine azul marino opak marineblau blu	25	bleu nuit azul oscuro dunkelblau azzurro scuro	85	vert pastel verde pastel pastelgrün verde pastello	68	vert glacé verde frosted gefrostet grün verde frosted	59	vert pomme verde manzana apfelgrün verde mela
88	vert clair verde clear transparentgrün verde trasparente	82	vert foncé glacé verde oscuro frosted gefrostet dunkelgrün verde scuro frosted	05	vert verde opak grün verde	72	vert menthe verde oscuro clear transparentdunkelgrün verde scuro trasparente	20	vert foncé verde oscuro opak dunkelgrün verde scuro
2B	kaki jungla opak dschungelgrün kaki	3B	kaki glacé jungla frosted gefrostet dschungelgrün kaki frosted	29	bronze oro viejo bronze oro brunito	47	argent plata silber argento	18	métal metal metall metallizzato
06	gris foncé gris grau grigio	27	gris foncé gris oscuro dunkelgrau grigio scuro	02	noir negro opak schwarz nero	4A	pure argent plata silber argento puro	75	argent métallisé plata metálico metallcsiber argento metallizzato
5A	bleu ardoise azul pizarra schieferblau blu ardesia	7A	gris ombre gris oscuro anthrazit grigio	35	chrome cromo premiumsilber cromato	8A	bronze bronce bronze bronz	8H	gris foncé frost gris oscuro clear transparentesdunkelgrau grigio scuro trasparente

The colours shown above are for reference only. Actual colour may vary slightly depending on the product / Ces couleurs sont de nature indicative et non contractuelle. Leur rendu peut donc varier en fonction de la matière sur laquelle elle sont apposées / Los colores arriba indicados, son sólo una referencia. El color real puede variar dependiendo del producto / Die oben angeführten Farben dienen ausschließllich der Veranschaulichung. Leichte Abweichungen können je nach Produkt entstehen / I colori esposti sopra sono solo un riferimento. I colori reali possono essere leggermente diversi, a seconda del prodotto.



www.bicgraphic.com

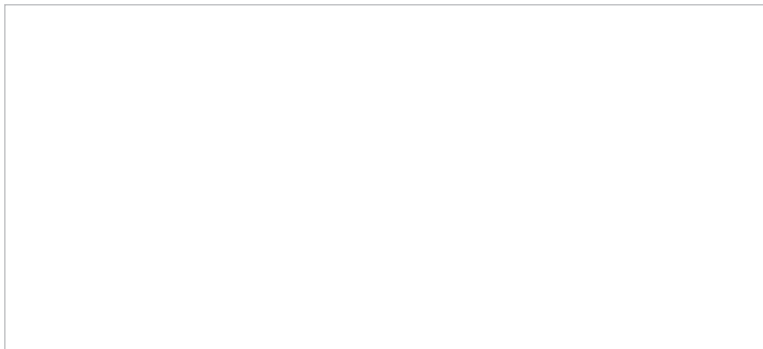

6,00 €; 4.65 GBP; 56 SEK; 45 DKK; 49 NOK; 24 PLN; 7,8 CHF
ISO 9994 & EN13869 Lighters / Briquets / Encendedores / Feuerzeuge / Accendini

©2015 BIC Graphic Europe



PRINTED IN EUROPE